



# Rexnord 9406 Series MatTop Chain

## FULL METAL PASTEURIZER BELT



Rexnord continuously develops new conveyor products that meet the performance demands of the marketplace. The new developed Rexnord 9406 Series MatTop Chain is a full metal pasteurizer chain that has been specifically developed for glass container handling but is suitable for can applications as well.

### MINIMIZED DOWNTIME

The robust design of the chain in combination with the perforated surface execution of the top plates minimizes downtime caused by broken glass. The stiffness of the chain results in no elastic elongation at the drive, a very smooth and steady forward motion which improves bottle stability. The stiffness also allows a minimal catenary of the chain which is beneficial when used in a double deck pasteurizer.

The chain can be combined with a self-clearing dynamic transfer which guarantees all bottles being cleared of the pasteurizer without any human handling.

### HIGH STRENGTH

The full metal execution features a high reliability and a high strength in combination with a high wear and chemical resistance. The chain has been designed in full stainless steel which makes sure that corrosion has no chance in the pasteurizer.

### SUSTAINABILITY

Optimize your productivity with the Rexnord 9406 Series MatTop Chain. Less downtime in combination with a self-clearing free flow chain make sure that your production will be optimized.

### COMPATIBILITY

The Rexnord 9406 Series MatTop Chain is not compatible with other pasteurizer chains.

### NEW DESIGNED SPROCKETS

The Rexnord 9406 Series MatTop Chain runs on new designed plastic non split sprockets.

### Key Industry

- Beverage

### Key Application

- Glass

### General Specifications

- Heavy load capability
- Pitch 61mm/2.4 inch
- Full stainless steel
- Single positrack

### Questions?

Contact your local Rexnord FlatTop Customer Service Representative

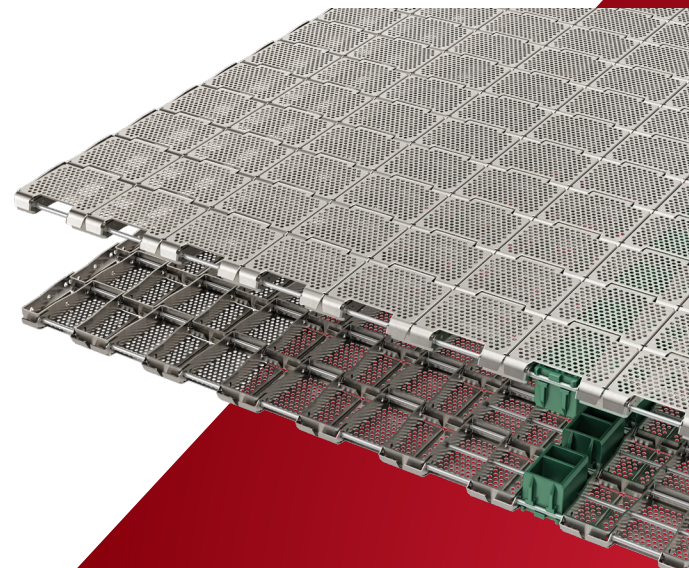

### Rexnord 9406 Series MatTop Chain Specifications

Top Plate Material	Matrod material	Temperature				Chain Strength		Approximate Weight		Backflex radius		Open Area
		Fahrenheit		Celsius		lbs/ft	N/m	lbs/ft2	Kg/m2	mm	inch	
		min	max	min	max							
Stainless steel	Stainless steel	39°F	219°F	+4°C	104°C	1507	22.000	3.072	15	75	2.953	29%

### General information

- Picket, positrack rod, rivet and plug all made of stainless steel
- Positrack made of Ultra Stabilized PolyPropylene
- Positrack can be positioned left (PT-L) or right (PT-R) under second top plate
- Inner sprockets are molded, outer sprockets are machined
- The Rexnord 9406 Series MatTop Chain is suitable for all pasteurizer machines. The chain is available in widths of 126" up to 189" in increments of 3". Widths smaller than 126" can be available upon request.

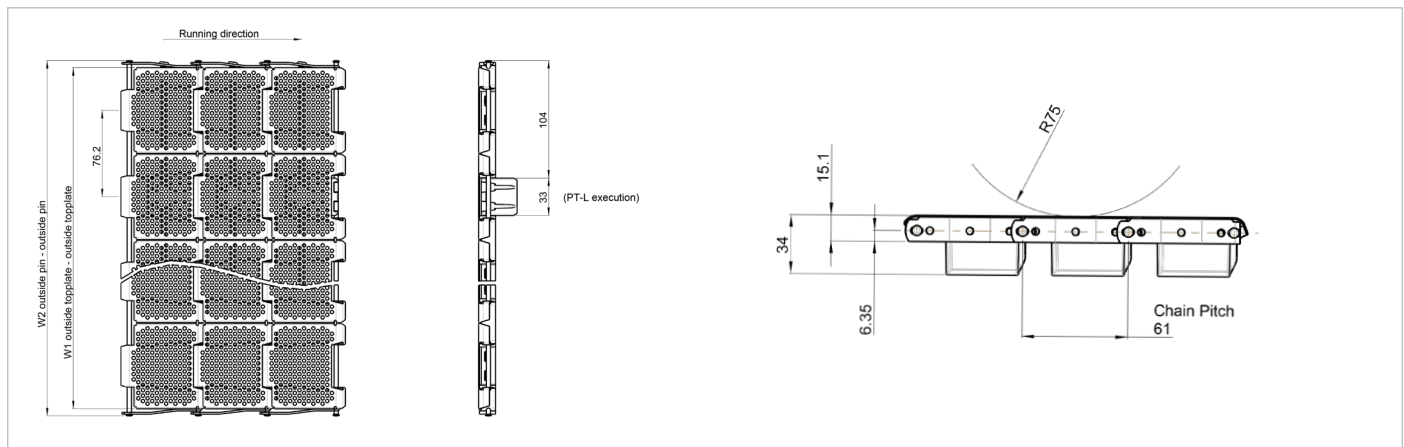

### Dimensions

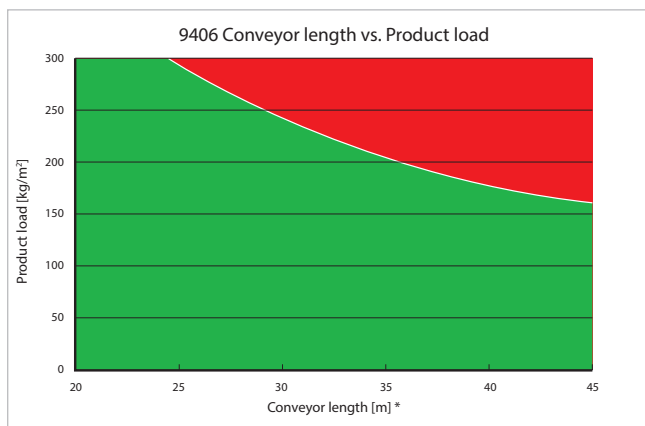

Maximum length of the chain

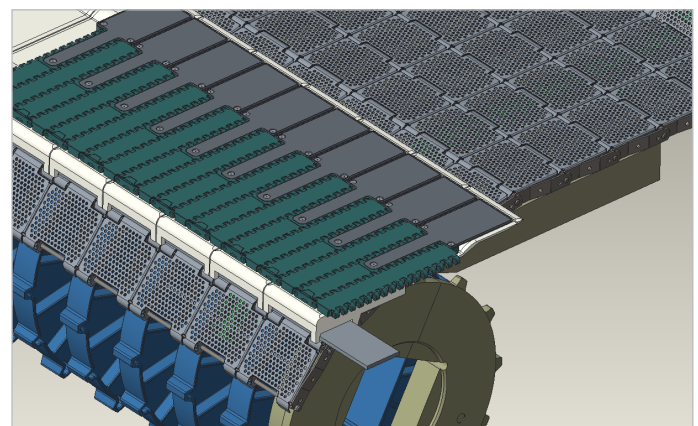

Dynamic transfer and sprocket

\* Please contact Application Engineering for exact calculations on product load in combination with length of chain.