



AUTOGARD® F400 SERIES TORQUE LIMITER

METRIC AND IMPERIAL OVERVIEW



Autogard® F400 Series Torque Limiter



FOR MORE THAN 80 YEARS, Autogard® products have led the industry in overload protection with high-quality products, design innovation and production. Autogard products are manufactured to meet ISO 9001 using the latest machine tools and high-quality materials.

The Autogard F400 Series has been designed to meet the need for a high- and low-speed, free-wheeling torque limiter. The F400 Series incorporates a reverse-to-reset function using two sets of balls on concentric pitch circles, providing longer life than competitive models. Working like a mechanical “fuse” to protect the weakest member of the drive train, the most effective location for a torque limiter is as close as possible to the component being protected.

DISENGAGEMENT ON OVERLOAD

When an overload condition occurs, the internal mechanism of the torque limiter creates an instant disconnection of the inertias between the driving and driven sides. The coupling or driven media attached to the adaptor is now completely free to rotate. Although the F400 Series has been designed to run freely after disengagement, it is recommended that a shutdown switch is incorporated to avoid wear.

RE-ENGAGEMENT

Re-engagement occurs when either the driving side is reversed, or the driven side is advanced. Resetting must be done at low speed to permit the engaging mechanism to function properly in either direction and to prevent potential damage.

Size	Max Rotation to Reset
2	75°
3	75°
4	75°
5	75°
6	39°
7	30°
8	34°

The resetting can be done manually or automatically by slowly inching the motor in reverse.

The F400 Series comes as standard as a Random Reset style torque limiter. This gives the following maximum angles of rotation to re-engage.

Single Position Reset (SR) designs are also available and must be specified at the time of ordering. These reset in a constant angular position.

FEATURES AND BENEFITS

- Proven design with thousands of torque limiters successfully in operation
- Accurate torque limitation prevents costly downtime
- Standard designs can accommodate large torque ranges
- Instantaneous disengagement protects equipment from damaging inertias
- Bi-direction protection
- Operates at high or low speeds
- Automatic or manual re-engagement by reversing the unit
- Offered in a large number of styles ensuring the right solution is available for applications such as:
 - Flexible couplings
 - Timing and HTD drives
 - Chain and sprocket drives
 - Flywheel or large gear mounts
- Springs can be inspected and changed without removing the torque limiter from the drive train

SELECTION

Data required for torque limiter selection:

- Kilowatt or horsepower (hp) and rpm of the driver
- Shaft details of the driving and driven equipment

(1) Calculate the nominal torque:

$$\text{Torque (Nm)} = \text{kW} \times 9550 / \text{rpm}$$

$$\text{Torque (lb-in)} = \text{hp} \times 63025 / \text{rpm}$$

Consideration should then be given to start torque or other special circumstances depending on the position chosen in the drive system. Choose a set torque with a suitable margin over nominal. Select the torque limiter which has a higher torque rating.

(2) Check limiting conditions:

- Check hub bore capacity
- Check the torque limiter dimensions such as the overall length and outside diameter

(3) Select and specify the appropriate drive medium or coupling.

All Autogard F400 Series units may be supplied from the factory finish bored and torque set.

ORDERING THE F400 SERIES TORQUE LIMITER

When ordering, please provide the following designation:
Type / Size / Feature / S1 bore / S2 bore.

Springs: Choose spring assembly. Refer to **Table 2** on **page 11**. Specify factor torque setting if desired.

Features: RR – Random Reset (standard)
SR – Single Position Reset (optional)

S1 Bore & S2 Bore: Please specify metric or imperial
Standard bore tolerance = H8 + normal fit key

Example: F402 / 3 / SR / S1 40mm

Refers to a type F402, size 3 torque limiter designed for Single Position Reset.

Bore S1 = 40 mm

Also specify:

- Torque setting or torque range required
- Pulley or sprocket details where required



APPLICATIONS

Conveyors

Shredders

Reel Stands

Billet Transfer Drives

Extruders

Model F403

F403 General Purpose Model to accept customer-supplied couplings and drive media.

Size	Torque ①				Max Speed rpm	Weight ③		Mass Moment of Inertia MR ²			
	Min		Max					Hub Side		Flange Side	
	Nm	lb-in	Nm	lb-in		kg	lb	kg-m ²	lb-in ²	kg-m ²	lb-in ²
2	20	180	220	2000	3600	6.7	14.8	0.0072	25	0.004	14
3	60	500	678	6000	3600	12.3	27.1	0.022	74	0.012	40
4	75	660	1130	10000	2000	16.7	36.8	0.036	120	0.021	71
5	225	2000	2540	22500	2000	39.7	87.5	0.16	560	0.08	270
6 ④	1100	9750	5650	50000	1800	63	139	0.28	960	0.19	650
7 ④	1500	13300	11300	100000	1500	114.4	252	0.73	2500	0.61	2100
8 ④	3500	31000	24860	220000	1000	205.8	454	1.91	6500	1.58	5400

① For higher torque applications, consult Regal Rexnord.

② Higher speeds may be allowed under certain conditions. Please consult Regal Rexnord.

③ Weights and moments of inertia apply to unbored hub.

④ Designs may vary for min torque, max speed, weight and mass moment of inertia specifications. Please specify or consult Regal Rexnord for assistance.

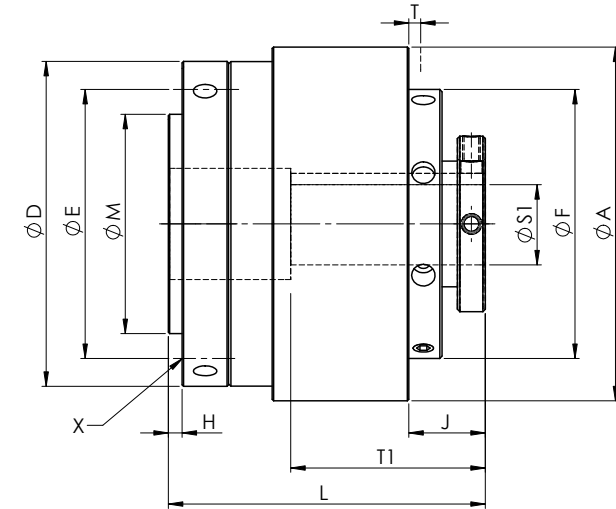

Size	Max Bore S1 ①		A		D		E		F		H		J ②		L		M		T		T1		X		
	mm	in	mm	in	mm	in	mm	in	mm	in	mm	in	mm	in	mm	in	mm	in	mm	in	mm	in	Size mm	Size mm x in	Spacing
2	34	1.3	121	4.76	111	4.38	92	3.62	92	3.62	4.75	0.187	26.2	1.03	108	4.27	75 j7	2.9528 j7	2.85	0.112	66	2.6	M8 x 15	M8 x 0.59	6X 60°
3	50	1.85	156	6.14	146	5.75	114	4.49	135	5.31	4.8	0.189	27.1	1.07	115	4.53	95 j7	3.7402 j7	3.48	0.137	114	4.51	M10 x 15	M10 x 0.59	7X 51.4°
4	64	2.36	176	6.93	167	6.57	144	5.67	150	5.91	4.8	0.189	28.2	1.11	121	4.78	122 j7	4.8031 j7	3.48	0.137	121	4.77	M12 x 15	M12 x 0.59	7X 45°
5 ③	85	3.1875	237	9.33	223	8.78	184	7.24	205	8.07	6.4	0.252	43.9	1.73	163	6.43	155 j7	6.1024 j7	4.4	0.173	164	6.44	M16 x 20	M16 x 0.79	8X 45°
6 ③	100	4	260	10.2	260	10.2	235	9.25	235	9.25	37.2	1.46	23	0.906	218	8.58	200 j7	7.8740 j7	5.33	0.21	218	8.58	M16 x 22	M16 x 0.87	9X 40°
7 ③	127	5	311	12.2	311	12.2	302	11.9	283	11.1	24.4	0.961	26	1.02	245	9.65	265 j7	10.4331 j7	6.3	0.248	245	9.65	M20 x 36	M20 x 1.4	10X 36°
8	152	6	385	15.2	385	15.2	342.9	13.5	362	14.3	1.52	0.060	36	1.42	300	11.8	366 H7	14.4094 H7	8.1	0.319	300	11.8	M16 x 50	M16 x 2.0	6X 45°

① For max bores greater than 25 mm, use rectangular parallel keys.

② For sizes 6 and above, clearance is required for adjustment.

③ Mounting details may vary for H, M and X. Please specify or consult Regal Rexnord for assistance.

Model F405 and F407

F405 Model includes Thomas® XTSTRS for angular misalignment only, F407 Model includes Thomas XTSTR52 to accommodate angular and parallel offset misalignment.

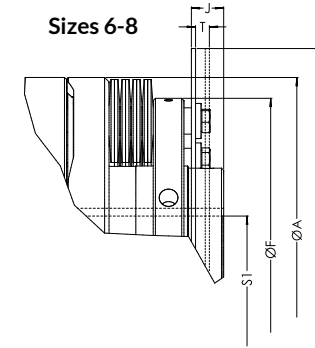
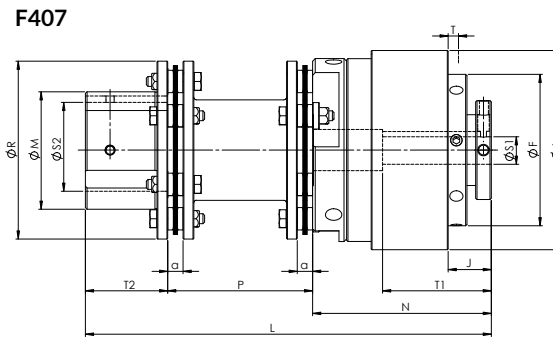
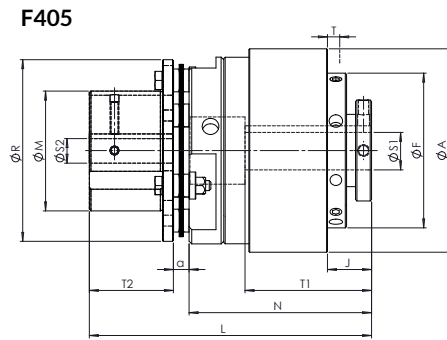

Size	Torque ①				Max Speed ② rpm	F405						F407					
	Min		Max			Mass ③		Inertia Hub Side ③		Inertia Flange Side ③		Mass ③		Inertia Hub Side ③		Inertia Flange Side ③	
	Nm	lb-in	Nm	lb-in		kg	lb	kg-m ²	lb-in ²	kg-m ²	lb-in ²	kg	lb	kg-m ²	lb-in ²	kg-m ²	lb-in ²
2	20	180	220	2000	3600	8.6	19	0.0072	24.6	0.0052	17.8	9.7	21.4	0.0072	24.6	0.0069	23.5
3	60	500	678	6000	3600	17.9	39.5	0.022	74.4	0.02	68.5	20.5	45.2	0.021	73	0.027	93.2
4	75	660	1130	10000	2000	22.5	49.6	0.037	125	0.03	102	24.9	54.9	0.036	123	0.036	123
5	225	2000	2540	22500	2000	59.2	131	0.17	568	0.15	523	68.5	151	0.17	569	0.21	731
6	1100	9750	5650	50000	1800	100	220	0.28	957	0.44	1500	112	247	0.28	957	0.53	1810
7	1500	13300	11300	100000	1500	166	366	0.74	2530	0.97	3310	185	408	0.74	2530	1.2	4070
8	3500	31000	24860	220000	1000	314	692	2.1	7140	2.8	9470	347	765	2.1	7040	3.5	11800

① For higher torque applications, consult Regal Rexnord.

② Higher speeds may be allowed under certain conditions. Please consult Regal Rexnord.

③ Weights and moments of inertia apply to unbored hubs with type XTSTRS couplings.

Size	Max Bore S1 ①		Max Bore S2		A		F		J ②		L				a		M		N		P ③		R		H		T		T1		T2	
	mm	in	mm	in	mm	in	mm	in	mm	in	F405		F407		mm	in	mm	in	mm	in	mm	in	mm	in	mm	in	mm	in	mm	in		
											mm	in	mm	in																		
2	34	1.3	50	2	121	4.76	92	3.62	26.2	1.03	168	6.61	246	9.7	9.34	0.368	71.8	2.83	108	4.27	88	3.46	108	3.46	-	-	2.85	0.112	66	2.6	50	1.97
3	50	1.85	65	2.5	156	6.14	135	5.31	27.1	1.07	213	8.37	305	12	10.4	0.408	92.1	3.63	121	4.78	103	4.06	140	4.06	-	-	3.48	0.137	114	4.51	81	3.19
4	64	2.36	65	2.5	176	6.93	150	5.91	28.2	1.11	219	8.62	312	12.3	10.4	0.408	92.1	3.63	128	5.03	103	4.06	140	4.06	-	-	3.48	0.137	121	4.77	81	3.19
5	85	3.1875	105	4	237	9.33	205	8.07	43.9	1.73	300	11.8	437	17.2	15.8	0.622	147	5.78	175	6.87	152	5.98	218	5.98	-	-	4.4	0.173	164	6.44	110	4.33
6	100	4	130	4.75	260	10.2	235	9.25	23	0.906	371.2	14.6	529	20.8	18.4	0.725	178.6	7.03	227.8	8.97	176	6.93	264	6.93	304.8	12.0	5.33	0.21	218	8.58	130	4.92
7	127	5	150	5.75	311	12.2	283	11.1	26	1.02	415.5	16.4	617	24.3	20.5	0.807	213.5	8.41	245	9.65	222	8.74	313	8.74	387.4	15.25	6.3	0.248	245	9.65	150	5.91
8	152	6	185	7.13	385	15.2	362	14.3	36	1.42	524.3	20.6	769	30.3	25.2	0.991	263	10.4	314.1	12.4	270	10.6	395	10.6	482.6	19.0	8.1	0.319	300	11.8	185	7.28

① For max bores greater than 25 mm, use rectangular parallel keys.

② For size 6 and above, clearance is required for adjusting bolt, consult Regal Rexnord.

③ P dimension is the minimum length. Longer spacers are available, consult Regal Rexnord.

Model F406N

F406N Model includes a flexible coupling that is torsionally resilient and accommodates angular, parallel and axial misalignment.

Size	Torque ①				Max Speed rpm ③	Weight ④		Mass Moment of Inertia MR ²			
	Min		Max ②					Hub Side		Flange Side	
	Nm	lb-in	Nm	lb-in		kg	lb	kg-m ²	lb-in ²	kg-m ²	lb-in ²
2	20	180	220	2000	3600	11	24.9	0.007	24	0.013	43
3	60	500	678	6000	3600	21	45.9	0.021	73	0.038	130
4	75	660	1130	10000	2000	34	75.2	0.037	120	0.1	350
5	225	2000	2540	22500	2000	74	162	0.17	570	0.32	1100
6	1100	9750	5650	50000	1800	120	258	0.28	960	0.82	2800
7 ⑤	1500	13300	11300	100000	1700	-	-	-	-	-	-
8 ⑤	3500	31000	24860	220000	1000	-	-	-	-	-	-

① For higher torque applications, consult Regal Rexnord.

② See spring selection on page 11 for torque range with specific springs.

③ Higher speeds may be allowed under certain conditions. Please consult Regal Rexnord.

④ Weights and moments of inertia apply to unbored hubs.

⑤ Please consult Regal Rexnord for assistance on specifications for these sizes.

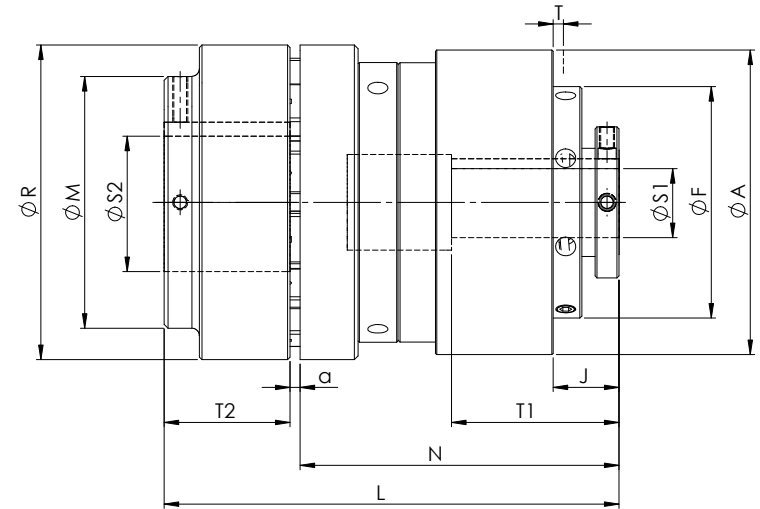

Size	Max Bore S1 ①		Max Bore S2 ①		A		F		J ②		L		M		N		R		T		T1		T2		a	
	mm	in	mm	in	mm	in	mm	in	mm	in	mm	in	mm	in	mm	in	mm	in	mm	in	mm	in	mm	in	mm	in
2	34	1.3	60	2.36	121	4.76	92	3.62	26.2	1.03	180	7.07	100	3.94	127	5.0	125	4.92	2.85	0.112	66	2.6	50	1.97	3	0.12
3	50	1.85	70	2.76	156	6.14	135	5.31	27.1	1.07	202	7.96	108	4.25	138	5.43	160	6.3	3.48	0.137	114	4.51	60	2.36	4	0.16
4	64	2.36	85	3.35	176	6.93	150	5.91	28.2	1.11	233	9.15	140	5.51	149	5.86	200	7.87	3.48	0.137	121	4.77	80	3.15	4	0.16
5	85	3.1875	100	3.94	237	9.33	205	8.07	43.9	1.73	304	12	165	6.5	198.5	7.81	250	9.84	4.4	0.173	164	6.44	100	3.94	5.5	0.22
6	100	4	120 ③	4.72	260	10.2	235	9.25	23	0.906	357	14.1	200	7.87	226.5	8.91	315	12.4	5.33	0.21	218	8.58	125	4.92	5.5	0.22
7 ④	127	5	160	6.3	311	12.2	283	11.1	26	1.02	-	-	265	10.4	-	-	440	17.3	6.3	0.248	245	9.65	180	7.09	7.5	0.30
8 ④	152	6	200	7.87	385	15.2	362	14.3	36	1.42	-	-	320	12.6	-	-	560	22	8.1	0.319	300	11.8	220	8.66	9	0.35

① Bores are furnished for clearance fit unless otherwise specified by customer.

② For size 6 and above, clearance is required for adjustment, consult Regal Rexnord.

③ Smaller bores may be available under certain conditions. Please consult Regal Rexnord.

④ Please consult Regal Rexnord for assistance on specifications for these sizes.

Model F406W

F406W Model includes Wrapflex® torsionally soft coupling to accommodate angular and parallel offset misalignment.

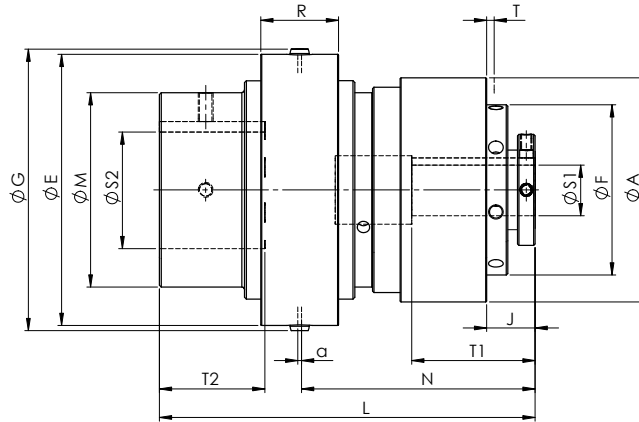

For the "R" dimension information please see Wrapflex catalogue (491-110)

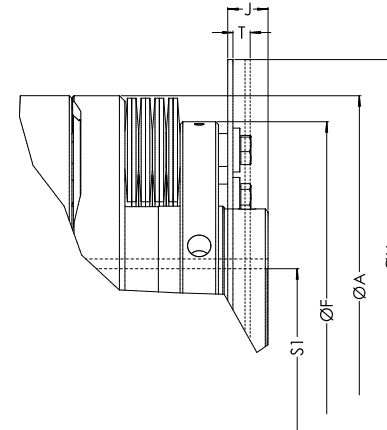

Torque adjustment mechanism for sizes 6 and 7

Size	Torque				Max Speed ① rpm	Weight ②		Mass Moment of Inertia MR ² ②			
	Min		Max			kg	lb	Hub Side		Flange Side	
	Nm	lb-in	Nm	lb-in				kg·m ²	lb-in ²	kg·m ²	lb-in ²
2	20	180	220	2000	3600	12	26.7	0.0073	25	0.014	46
3	60	500	678	6000	3600	22	48.7	0.021	72	0.041	140
4	75	660	1130	10000	2000	39	84.9	0.037	130	0.13	440
5	225	2000	2540	22500	2000	79	173	0.16	560	0.38	1300
6	1100	9750	5650	50000	1800	130	278	0.28	960	0.83	2800
7	1500	13300	11300	100000	1700	210	456	0.74	2500	1.8	6300

① Higher speeds may be allowed under certain conditions. Please consult Regal Rexnord.

② Weights and moments of inertia apply to unbored hubs.

Size ①	Max Bore S1		Max Bore S2		A		E		F		G		H		J		L		M		N		R		T		T1		T2		a	
	mm	in	mm	in	mm	in	mm	in	mm	in	mm	in	mm	in	mm	in	mm	in	mm	in	mm	in	mm	in	mm	in	mm	in	mm	in	mm	in
2	34	1.3	65	2.875	121	4.76	147	5.79	92	3.62	153	6.02	-	-	26.2	1.03	203	8.01	105	4.13	141.8	5.58	41.6	1.64	2.85	0.112	66	2.6	57	2.24	2	0.0787
3	50	1.85	85	3.375	156	6.14	182	7.17	135	5.31	190	7.48	-	-	27.1	1.07	231	9.11	130	5.12	154.3	6.07	54.6	2.15	3.48	0.137	114	4.51	66	2.6	5	0.197
4	64	2.36	105	4.125	176	6.93	231	9.09	150	5.91	239	9.41	-	-	28.2	1.11	260	10.3	178	7.01	165.8	6.53	69.5	2.74	3.48	0.137	121	4.77	76	2.99	5	0.197
5	85	3.1875	135	5.25	237	9.33	267	10.5	205	8.07	278	10.9	-	-	43.9	1.73	339	13.3	210	8.25	223.7	8.81	67.2	2.65	4.4	0.173	164	6.44	100	3.94	5	0.197
6	100	4	160	6.125	260	10.2	310	12.2	235	9.25	321	12.6	304.8	12.0	23	0.906	394	15.5	251	9.88	-	-	75	2.95	5.33	0.21	218	8.58	120	4.72	5	0.197
7	127	5	190	7.25	311	12.2	370	14.6	283	11.1	381	15	387.4	15.25	26	1.02	457	18	270	10.6	-	-	85	3.35	6.3	0.248	245	9.65	140	5.51	6	0.236

① For size 6 and above, clearance is required for adjustment. Please consult Regal Rexnord.

Torque Limiter Engineering Information

DISENGAGEMENT SENSORS

The Autogard® F400 Series is designed to run freely upon disengagement. However, it is still critical to shut down the drive immediately when disengagement occurs to avoid premature wear of the torque limiter. The recommended method of shutting down the drive is through the use of a customer supplied mechanical limit switch or proximity sensor shown in **Figure 1** using the dimensions in **Table 1**. However, it is preferable to use the slide plate movement on disengagement to operate a limit switch, which switches off the main drive and/or sounds an alarm.

The limit switch may be operated by a limit switch operating plate fitted to the slide plate or by the cover. In some circumstances a limit switch may be operated directly by the slide plate.

Figure 1 and **Table 1** give details of the limit switch plate and the movement on disengagement.

Table 1

Size		2	3	4	5	6	7	8
X	mm	2.85	3.48	3.48	4.4	5.33	6.3	8.1
X	in	0.112	0.137	0.137	0.173	0.21	0.248	0.319

PROTECTIVE FINISH

The standard protective finish applied to Autogard Torque Limiters is manganese phosphate plus oil dip. This treatment provides a high level of protection with good corrosion resistance and is suitable for most environments. Other finishes can be applied for situations where exceptional environments necessitate high levels of protection – consult Regal Rexnord.

Figure 1

Sizes 2-5

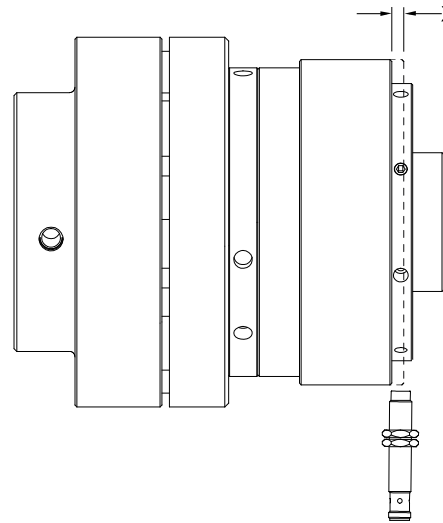

Sizes 6-8

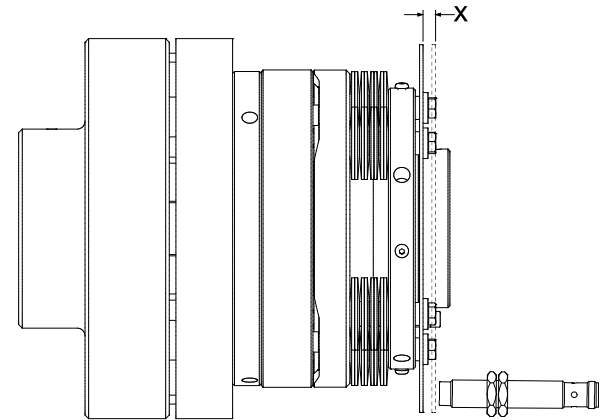

GENERAL SAFETY

Autogard Torque Limiters are reliable units, built to high standards of workmanship. Similar to all mechanical devices, each application must be considered on its own merits with reference to safety (i.e., lifting equipment, explosive conditions, etc). As rotating components, adequate guarding must be provided, in accordance with local codes. The intended use of torque limiters is for the protection of industrial machinery and should not be regarded as human safety devices. Regal Rexnord™ staff are always available to discuss particular applications.

Torque Limiter Engineering Information *Cont.*

SPRING SELECTIONS

The full range of torque for each unit, sizes 2 to 5 is achieved by a number of positions in which coil springs are located. Calculate theoretical running torque at a chosen location using the following formula:

$$\text{Torque (Nm)} = \frac{\text{kW} \times 9550}{\text{rpm}}$$

$$\text{Torque (lb-in)} = \frac{\text{hp} \times 63025}{\text{rpm}}$$

For these sizes, select the proper spring assembly so that the desired tripping torque will be close to the max torque of the spring assembly.



Table 2: Standard Spring Selection

Size	Standard Torque Adjustment Springs			
	Spring Assembly		Torque Range	
	Quantity	Positions	in-lb	Nm
2	8	Outer	700 - 2000	80 - 226
	6	Outer	500 - 1500	60 - 170
	4	Outer	300 - 1000	40 - 115
	2	Outer	180 - 550	20 - 60
3	6	Inner & Outer	2200 - 6000	250 - 678
	6	Outer	1400 - 4000	160 - 450
	4	Outer	1000 - 2700	110 - 300
	2	Outer	500 - 1300	60 - 150
4	8	Inner & Outer	4800 - 10000	550 - 1130
	8	Outer	3100 - 6700	350 - 750
	6	Outer	2300 - 5000	260 - 560
	4	Outer	1400 - 3300	160 - 375
	2	Outer	660 - 1700	75 - 190
5	8	Inner & Outer	10600 - 22500	1200 - 2540
	8	Outer	8000 - 17000	900 - 2000
	6	Outer	6000 - 13000	680 - 1500
	4	Outer	4000 - 8500	450 - 1000
	2	Outer	2000 - 4500	225 - 500
6	8	Spring Stacks	20000 - 50000	2250 - 5650
	6	Spring Stacks	15000 - 37500	1700 - 4250
	4	Spring Stacks	9750 - 25000	1100 - 2800
7	12	Spring Stacks	40000 - 100000	4500 - 11300
	8	Spring Stacks	26500 - 66000	3000 - 7500
	6	Spring Stacks	20000 - 50000	2250 - 5650
	4	Spring Stacks	13500 - 33000	1500 - 3800
8	12	Spring Stacks	9000 - 22000	10000 - 24860
	8	Spring Stacks	6000 - 146000	7000 - 16500
	6	Spring Stacks	45000 - 110000	5000 - 12430

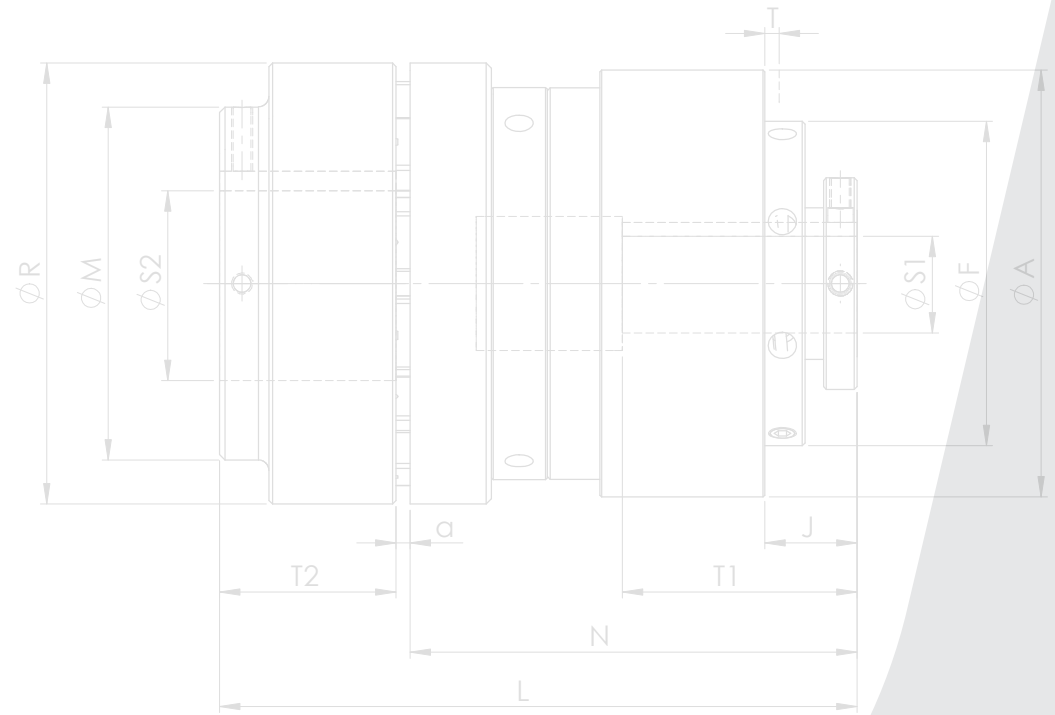
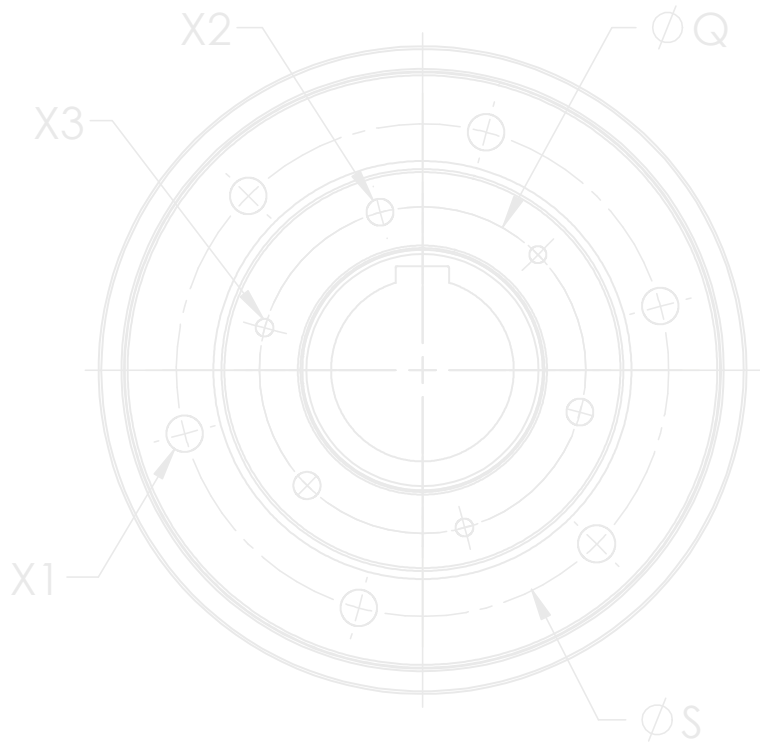

Regal Rexnord

Contact us: [rexnord.com/contact](https://www.rexnord.com/contact)

[regalrexnord.com](https://www.regalrexnord.com)

The proper selection and application of products and components, including assuring that the product is safe for its intended use, are the responsibility of the customer. To view our Application Considerations, please visit <https://www.regalrexnord.com/Application-Considerations>.

To view our Standard Terms and Conditions of Sale, please visit <https://www.regalrexnord.com/Terms-and-Conditions-of-Sale> (which may redirect to other website locations based on product family).

"Regal Rexnord" is not indicative of legal entity. Refer to product purchase documentation for the applicable legal entity.

Regal Rexnord, Rexnord, Autogard, Thomas, and Wrapflex are trademarks of Regal Rexnord Corporation or one of its affiliated companies.

© 2019, 2024 Regal Rexnord Corporation. All Rights Reserved.
MCB24007E • Form# PTE1-002E

