



Tollok Locking Assemblies





Why Choose Tollok™ Locking Assemblies?

WHY CHOOSE REGAL REXNORD?

When it comes to providing highly engineered products that improve productivity and efficiency for industrial applications worldwide, Regal Rexnord is the most reliable name in the industry. Our commitment to customer satisfaction and superior value extends to every area of our business.

DELIVERING THE LOWEST TOTAL COST OF OWNERSHIP

High quality products are designed to help prevent equipment downtime, increase productivity, and deliver dependable operation.

VALUABLE EXPERTISE

An extensive product offering is accompanied by global sales specialists, customer service, and maintenance support teams, available anytime.

SOLUTIONS TO ENHANCE EASE OF DOING BUSINESS

Our commitment to operational excellence means you benefit from getting the right products to the right place at the right time.

PROVEN RELIABILITY, DEPENDABLE EXPERTISE, BROAD RANGE OF OPTIONS

For almost 50 years, Tollok products have led the industry in locking assemblies. Our robust product offering features a wide range of options from simple and compact designs to advanced features. Our full line of locking assemblies can be customized to fit our customers ever-changing application needs and are ideal for use in heavy-duty and specially engineered environments.

DELIVERING THE LOWEST TOTAL COST OF OWNERSHIP

Tollok designs its product by using state-of-the-art analysis tools to assure the most accurate designs possible. CAD drawings are directly integrated in a production system through CAD-CAM technology. This combined with the latest manufacturing methodology ensures high precision products with a short lead time.

CONNECTING TECHNOLOGY WITH APPLICATION SOLUTIONS

Tollok offers a broad range of internal locking assemblies, shrink discs, and rigid couplings to fit to a wide range of applications. Tollok locking assemblies could be an alternative to a shaft/hub connection such as: key, splined, press fit, OD bushing, or Taper Lock bushing. Tollok products are dimensionally interchangeable with most industry standard units.

CONNECTING TECHNOLOGY WITH THE BEST SERVICE

Our product line is complemented with industry leading service. Each unit is protected, packed, and suitably prepared for shipping. Tollok products are distributed worldwide. Regardless of the location, our customers can rely on our experienced application engineers for technical support.

INDUSTRIES SERVED

Aggregate • Agriculture • Air Handling • Cement • Forest Products • Mining • Oil & Gas • Petrochemical • Primary Metals • Power Generation • Water Treatment

Tollok™ Locking Assemblies

LOCKING ASSEMBLIES

TLK 110

Page 7

Self-centering
Medium-high torque
Available from 6 mm to 130 mm diameter
Restricted radial encumbrance

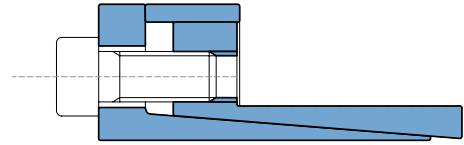

TLK 130

Page 9

Self-centering
High torque
Available from 18 mm to 240 mm diameter
Quick installation time



TLK 131

Page 9

Self-centering
Medium torque
Available from 18 mm to 240 mm diameter
Low surface pressures

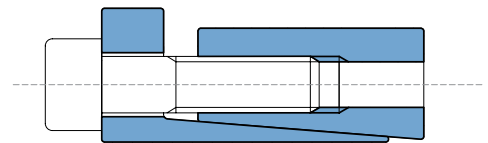

TLK 132

Page 11

Self-centering
Medium-high torque
TLK 132: Available from 18 mm to 200 mm diameter

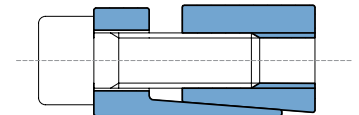

TLK 133

Page 11

Self-centering
Medium torque
TLK 133: Available from 18 mm to 200 mm diameter

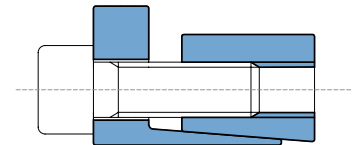

TLK 200

Page 13

Not self-centering
Medium torque
Available from 17 mm to 340 mm diameter
Self dismantling

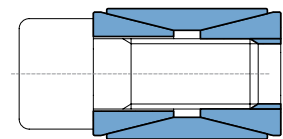

Tollok™ Locking Assemblies

LOCKING ASSEMBLIES

TLK 300

Page 15

Not self-centering
Low torque
Available from 9 mm to 340 mm diameter
Restricted radial encumbrance

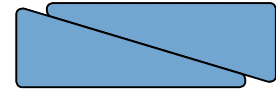

TLK 350

Page 17

Self-centering
Medium-high torque
Available from 6 mm to 50 mm diameter
Restricted radial encumbrance

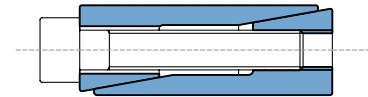

TLK 400

Page 18

Self-centering
Very high torque
TLK 400: Available from 45 mm to 340 mm diameter
Even pressures distribution

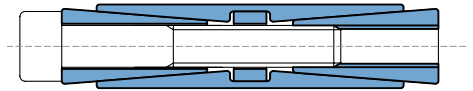

TLK 450

Page 20

Self-centering
Very high torque
TLK 450: Available from 25 mm to 340 mm diameter
Application economically advantageous

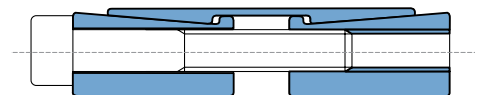

Tollok™ Locking Assemblies

SHRINK DISCS

TLK 500

Page 22

Rigid coupling
Medium torque
Available from 17 mm to 80 mm diameter
Quick installation and dismantling

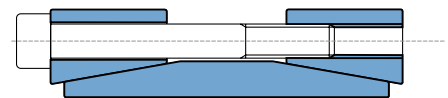

TLK 603

Page 23

Self-centering
High / very high torque
TLK 603: Available from 14 mm to 350 mm diameter
Quick installation time

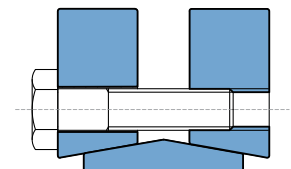

TLK 622/681

Page 27

Self-centering
High / very high torque
TLK 622/681: Available from 12 mm to 350 mm diameter
Quick installation time

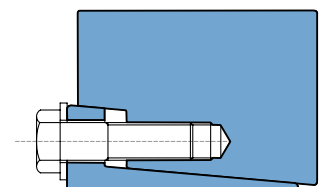

Tollok™ Locking Assemblies

APPLICATION EXAMPLES

EA01

Bearing axial fastening and gear locking by means of model TLK 350

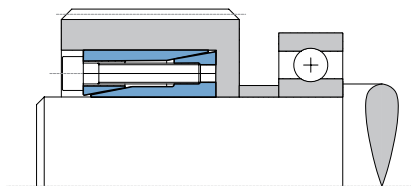

EA02

Chain sprocket locking by means of model TLK 130 with no split outside ring

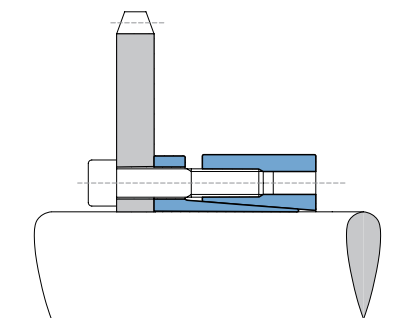

EA03

Thin plate locking by means of model TLK 133 with adapter ring

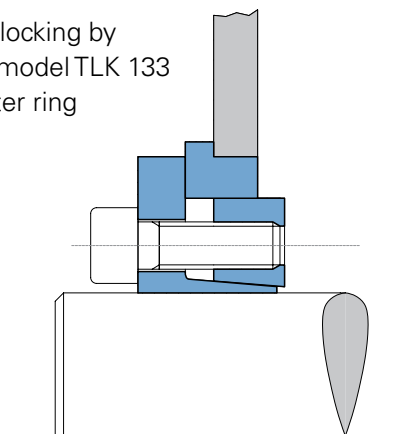

EA04

Hub locking by means of model TLK 200 with a special centering ring

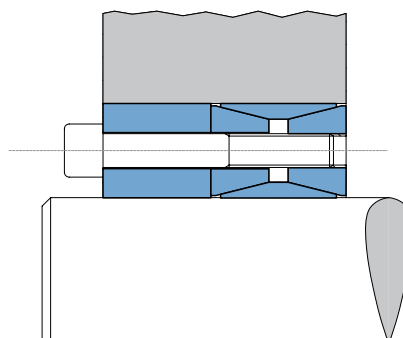

EA05

Large hub locking by means of special version of model TLK 400

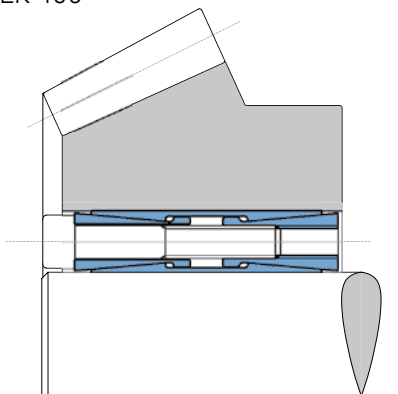

Tollok™ Locking Assemblies

APPLICATION EXAMPLES

EA07

Cam locking by means of special model TLK 133

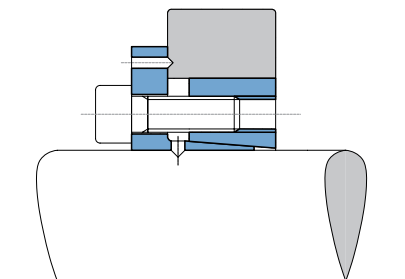

EA08

Use of model TLK 300 without spacer

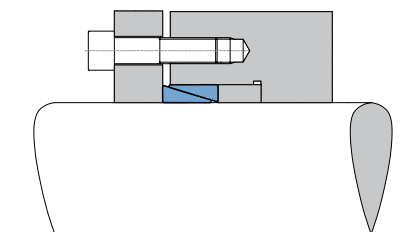

EA09

Use of several locking assemblies in presence of very heavy torque

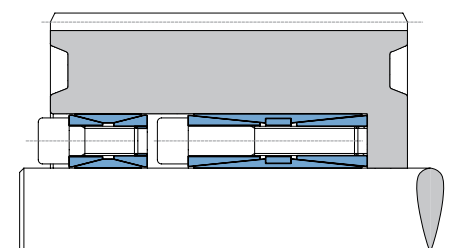

EA10

Use of model TLK 110 in presence of high rpm

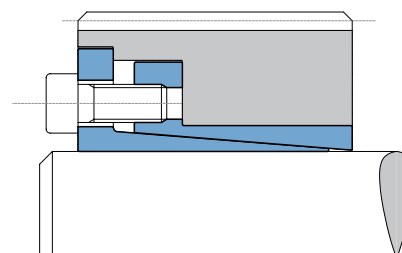

EA11

Special version of model TLK 132 with screws protection ring

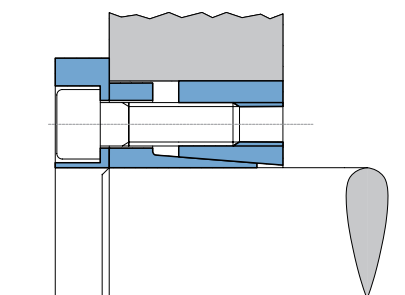

EA12

Special version of model TLK 132 with retaining ring

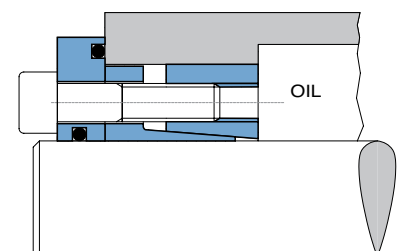

Tollok™ Locking Assemblies

TLK 110-Self-Centering

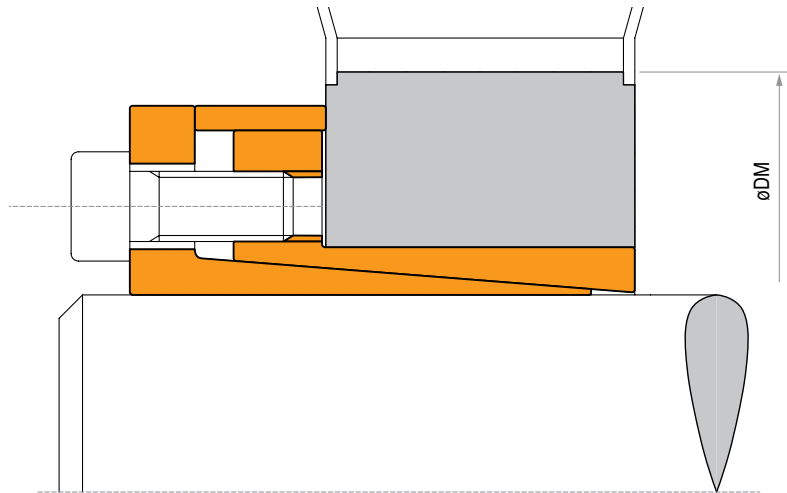

CHARACTERISTICS

- Medium-high torque
- Restricted hub diameter
- Limited installation time
- Very low surface pressure

INSTALLATION

Carefully clean the hub and shaft contact surfaces and apply a light oil film. Slide the locking assembly into the hub bore, insert the shaft and tighten all screws gradually and regularly in crossed sequence to reach the tightening torque M_s as indicated in the table.

The values M_t and F_{ax} indicated in the table are valid only in case of oil installation. Do not use any oil with **molibdenum bisulphide** or high pressure additives and not grease. Above substances notably reduce the friction coefficient.

DISMANTLING

Loosen the clamping screws. Insert the screws into the dismantling threading and tighten gradually and regularly in crossed sequence until the bottom cone is released.

If the element is to be reused, relubricate both screws and threadings.

TOLERANCES, SURFACE FINISH

A good surface finish by machine tool is sufficient. Maximum allowable surface finish:

Rt max 16 μm (Ra 3 μm - Rz 13 μm)

Maximum permissible tolerances:

h8 for shaft

H8 for hub

AXIAL MOVEMENT

TLK 110: during screws tightening the hub has no axial movement with respect to the shaft.

DM HUB CALCULATION

The pressure P_n in the hub can be compared to the inside pressure on a thick hollow cylinder.

For DM calculation see page 30.

Tollok™ Locking Assemblies

TLK 110-SELF-CENTERING

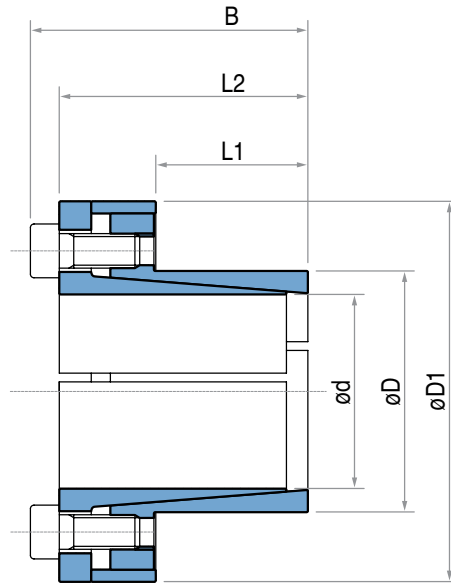

TLK 110 DIMENSIONS

Dimensions				Torque	Axial force	Surface pressures on		Tightening screws		Weight	
						Shaft	Hub	DIN912 12.9	Tightening torque		
d x D mm	L1 mm	L2 mm	B mm	D1 mm	M _t Nm	F _{ax} KN	p _w N/mm ²	p _n N/mm ²	N° x Type	M _s Nm	Kg
6 x 14	9	21	24	25	16	6	277	119	4 x M3	2	0,04
7 x 15	12	25	29	27	25	7	234	109	3 x M4	5	0,06
8 x 15	12	25	29	27	29	7	204	109	3 x M4	5	0,05
9 x 16	14	26	30	28	44	10	208	117	4 x M4	5	0,06
* 10 x 16	14	26	30	28	49	10	187	117	4 x M4	5	0,06
11 x 18	14	26	30	32	53	10	170	104	4 x M4	5	0,07
* 12 x 18	14	26	30	32	58	10	156	104	4 x M4	5	0,07
13 x 23	14	26	30	38	63	10	144	81	4 x M4	5	0,11
* 14 x 23	14	26	30	38	68	10	134	81	4 x M4	5	0,1
* 15 x 24	16	36	42	44	170	23	251	157	4 x M6	17	0,22
16 x 24	16	36	42	44	180	23	236	157	4 x M6	17	0,22
17 x 26	18	38	44	47	190	23	197	129	4 x M6	17	0,25
18 x 26	18	38	44	47	200	23	186	129	4 x M6	17	0,24
19 x 27	18	38	44	49	210	23	176	124	4 x M6	17	0,26
* 20 x 28	18	38	44	50	220	23	168	120	4 x M6	17	0,27
22 x 32	25	45	51	54	250	23	110	75	4 x M6	17	0,34
24 x 34	25	45	51	56	270	23	101	71	4 x M6	17	0,36
* 25 x 34	25	45	51	56	280	23	97	71	4 x M6	17	0,35
28 x 39	25	45	51	61	475	34	129	93	6 x M6	17	0,48
* 30 x 41	25	45	51	62	510	34	121	88	6 x M6	17	0,48
32 x 43	25	45	51	65	720	45	151	112	8 x M6	17	0,47
* 35 x 47	30	50	56	69	790	45	115	86	8 x M6	17	0,58
38 x 50	30	50	56	72	860	45	106	80	8 x M6	17	0,61
* 40 x 53	30	50	56	75	900	45	101	76	8 x M6	17	0,68
42 x 55	32	52	60	78	1750	84	166	127	8 x M8	41	0,76
45 x 59	40	65	73	85	1890	84	124	94	8 x M8	41	1,2
48 x 62	45	70	78	87	2010	84	103	80	8 x M8	41	1,2
* 50 x 65	45	70	78	92	2600	105	124	95	10 x M8	41	1,4
55 x 71	50	75	83	98	2850	105	101	79	10 x M8	41	1,6
* 60 x 77	50	75	83	104	3150	105	93	72	10 x M8	41	1,8
65 x 84	50	75	83	111	3400	105	86	66	10 x M8	41	2,1
70 x 90	60	91	101	119	5800	167	105	82	10 x M10	83	3
75 x 95	60	91	101	126	6200	167	98	78	10 x M10	83	3
80 x 100	65	96	106	131	8000	200	102	82	12 x M10	83	3,5
85 x 106	65	96	106	137	8500	200	96	77	12 x M10	83	3,6
90 x 112	65	96	106	144	11250	250	113	91	15 x M10	83	3,9
95 x 120	65	96	106	149	11850	250	107	85	15 x M10	83	4,4
100 x 125	65	96	106	154	15000	300	123	98	18 x M10	83	4,6
110 x 140	90	128	140	180	16000	291	78	61	12 x M12	145	8,7
120 x 155	90	128	140	198	17500	291	72	55	12 x M12	145	10,6
130 x 165	90	128	140	208	25000	389	88	69	16 x M12	145	11,3

* New standard.

Tollok™ Locking Assemblies

TLK 130/TLK 131-SELF-CENTERING

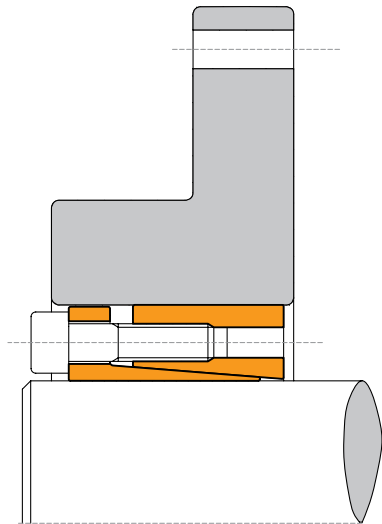

TLK 130

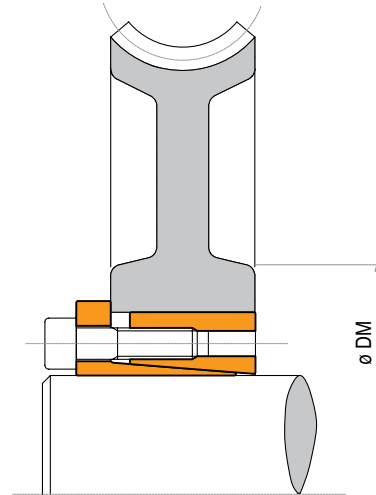

TLK 131

CHARACTERISTICS

- High torque
- Application economically advantageous
- Limited installation time
- Excellent shaft-hub perpendicularity

INSTALLATION

Carefully clean the hub and shaft contact surfaces and apply a light oil film. Slide the locking assembly into the hub bore, insert the shaft and tighten gradually and regularly in crossed sequence all screws to reach the tightening torque M_s as indicated in the table.

The values M_t and F_{ax} indicated in the table are valid only in case of oil installation. Do not use any oil with **molibdenum bisulphide** or high pressure additives and not grease. Above substances notably reduce the friction coefficient.

DISMANTLING

Loosen the clamping screws. Insert the screws into the dismantling threading and tighten gradually and regularly in crossed sequence until the back cone is released.

If the element is to be reused, relubricate both screws and threads.

TOLERANCES, SURFACE FINISH

A good surface finish by the machine tool is sufficient. Maximum allowable surface finish:

Rt max 16 µm (Ra 3 µm - Rz 13 µm)

Maximum permissible tolerances:

h8 for shaft

H8 for hub

AXIAL MOVEMENT

TLK 130: during screws tightening the hub has a slight axial movement with respect to the shaft.

TLK 131: during screws tightening the hub has no axial movement with respect to the shaft.

DM HUB CALCULATION

The pressure P_n in the hub can be compared to the inside pressure on a thick hollow cylinder.

For DM calculation see page 30.

Tollok™ Locking Assemblies

TLK 130/TLK 131-SELF-CENTERING

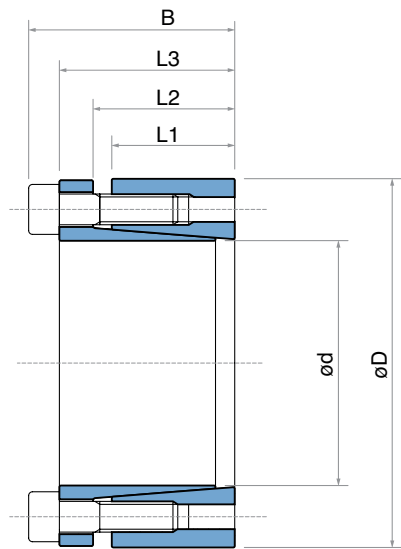

TLK 130

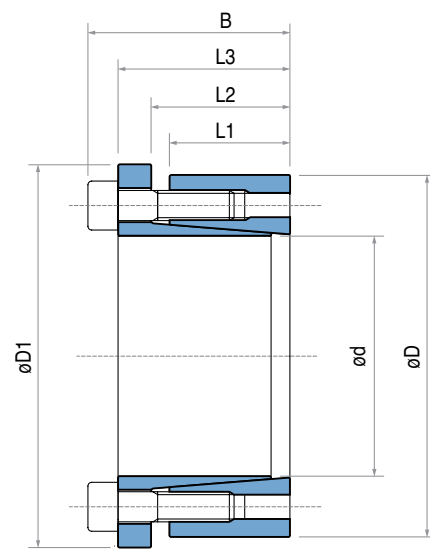

TLK 131

TLK 130 - TLK 131 DIMENSIONS

Dimensions				Only TLK 131	Tightening screws		TLK 130					TLK 131					
					DIN912 12.9	Tightening torque	Torque	Axial force	Surface pressures on		Weight	Torque	Axial force	Surface pressures on		Weight	
d x D mm	L1 mm	L2 mm	L3 mm	B mm	D1 mm	N° x Type	M _s Nm	M _t Nm	F _{ax} KN	P _w N/mm ²		P _n N/mm ²	Kg	M _t Nm	F _{ax} KN		P _w N/mm ²
18 x 47	26	30	41	47	53	6 x M6	17	490	55	310	119	0,4	300	34	193	74	0,5
19 x 47	26	30	41	47	53	6 x M6	17	510	55	294	119	0,4	320	34	183	74	0,5
* 20 x 47	26	30	41	47	53	6 x M6	17	540	55	279	119	0,4	340	34	174	74	0,5
22 x 47	26	30	41	47	53	6 x M6	17	600	55	254	119	0,4	370	34	158	74	0,5
24 x 47	26	30	41	47	56	6 x M6	17	650	55	233	112	0,4	400	34	145	70	0,5
* 25 x 50	26	30	41	47	56	6 x M6	17	680	55	223	112	0,4	420	34	139	70	0,5
28 x 55	26	30	41	47	61	6 x M6	17	760	55	199	102	0,5	470	34	124	63	0,6
* 30 x 55	26	30	41	47	61	6 x M6	17	820	55	186	102	0,5	510	34	116	63	0,6
32 x 60	26	30	41	47	66	8 x M6	17	1160	73	233	124	0,6	720	45	145	77	0,7
* 35 x 60	26	30	41	47	66	8 x M6	17	1270	73	213	124	0,5	790	45	133	77	0,6
38 x 65	26	30	41	47	71	8 x M6	17	1380	73	196	115	0,6	860	45	122	71	0,8
* 40 x 65	26	30	41	47	71	8 x M6	17	1450	73	186	115	0,6	900	45	116	71	0,6
42 x 75	30	35	49	57	81	6 x M8	41	2120	101	213	119	1	1320	63	133	74	1,2
* 45 x 75	30	35	49	57	81	6 x M8	41	2270	101	199	119	1	1410	63	124	74	1,1
48 x 80	30	35	49	57	86	8 x M8	41	3230	135	248	149	1,1	2010	84	155	93	1,3
* 50 x 80	30	35	49	57	86	8 x M8	41	3370	135	238	149	1	2100	84	149	93	1,1
55 x 85	30	35	49	57	91	8 x M8	41	3700	135	217	140	1,1	2310	84	135	87	1,2
* 60 x 90	30	35	49	57	96	8 x M8	41	4040	135	199	132	1,2	2520	84	124	83	1,3
65 x 95	30	35	49	57	101	8 x M8	41	4380	135	183	125	1,3	2730	84	114	78	1,4
* 70 x 110	40	45	59	69	117	8 x M10	83	7490	214	203	129	2,2	4670	133	126	80	2,5
75 x 115	40	45	59	69	122	8 x M10	83	8020	214	189	123	2,5	5000	133	118	77	2,6
* 80 x 120	40	45	59	69	127	8 x M10	83	8560	214	177	118	2,6	5330	133	111	74	2,8
85 x 125	40	45	59	69	132	10 x M10	83	11370	268	209	142	2,8	7080	167	130	88	2,8
* 90 x 130	40	45	59	69	137	10 x M10	83	12040	268	197	136	2,7	7500	167	123	85	3
95 x 135	40	45	59	69	142	10 x M10	83	12700	268	187	131	2,9	7920	167	116	82	3
* 100 x 145	46	52	68	80	153	8 x M12	145	15580	312	180	124	3,9	9710	194	112	77	4,5
110 x 155	46	52	68	80	163	8 x M12	145	17140	312	163	116	4,2	10680	194	102	72	4,8
120 x 165	46	52	68	80	173	10 x M12	145	23370	390	187	136	4,8	14570	243	117	85	5,5
130 x 180	46	52	68	80	188	12 x M12	145	30380	467	207	150	5	18940	291	129	93	6
140 x 190	50	57	76	90	199	10 x M14	230	37410	535	203	149	6,5	23300	333	126	93	7,5
150 x 200	50	57	76	90	209	12 x M14	230	48100	641	227	170	7	30000	400	141	106	7,7
160 x 210	50	57	76	90	219	12 x M14	230	51300	641	213	162	7	32000	400	133	101	8
170 x 225	50	57	76	90	234	14 x M14	230	63600	748	234	176	8,5	39650	467	146	110	9,8
180 x 235	50	57	76	90	244	14 x M14	230	67350	748	221	169	9	42000	467	138	105	9,8
190 x 250	50	57	76	90	259	15 x M14	230	76150	802	224	170	10,5	47500	500	140	106	11,4
200 x 260	50	57	76	90	269	16 x M14	230	85500	855	227	175	10,5	53300	533	141	109	11,4
220 x 285	64	72	94	110	294	12 x M16	355	98050	891	168	130	16,5	61150	556	105	81	17,5
240 x 305	64	72	94	110	314	15 x M16	355	133700	1114	192	151	18	83350	695	120	94	18,9

* New standard.

NOTE: it is possible to reduce the screws tightening torque down to 60% of the values indicated in above table; as a result M_t, F_{ax}, P_w, P_n are reduced proportionally.

Tollok™ Locking Assemblies

TLK 132/TLK 133-Self-Centering

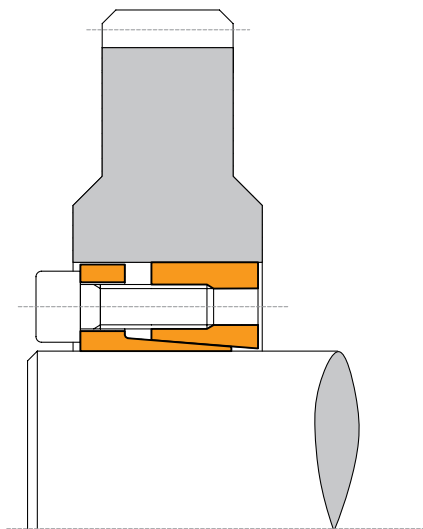

TLK 132

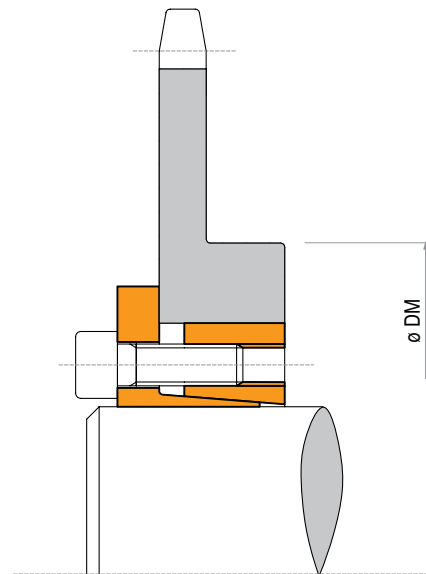

TLK 133

CHARACTERISTICS

- Medium-high torque
- Application economically advantageous
- Limited installation time
- Interchangeable with TLK 200

INSTALLATION

Carefully clean the hub and shaft contact surfaces and apply a light oil film. Slide the locking assembly into the hub bore, insert the shaft and tighten gradually and regularly in crossed sequence all screws to reach the tightening torque M_t , as indicated in the table.

The values M_t and F_{ax} indicated in the table are valid only in case of oil installation. Do not use any oil **with molybdenum bisulphide** or high pressure additives and not grease. Above substances notably reduce the friction coefficient.

DISMANTLING

Loosen the clamping screws. Insert the screws into the dismantling threading and tighten gradually and regularly in crossed sequence until the back cone is released. If the element is to be reused, relubricate both screws and threads.

TOLERANCES, SURFACE FINISH

A good surface finish by the machine tool is sufficient.

Maximum allowable surface finish:

Rt max 16 μm (Ra 3 μm - Rz 13 μm)

Maximum permissible tolerances:

h8 for shaft

H8 for hub

AXIAL MOVEMENT

TLK 132: during screws tightening the hub has a slight axial movement with respect to the shaft.

TLK 133: during screws tightening the hub has no axial movement with respect to the shaft.

DM HUB CALCULATION

The pressure P_n in the hub can be compared to the inside pressure on a thick hollow cylinder.

For DM calculation see page 30.

Tollok™ Locking Assemblies

TLK 132/TLK 133-SELF-CENTERING

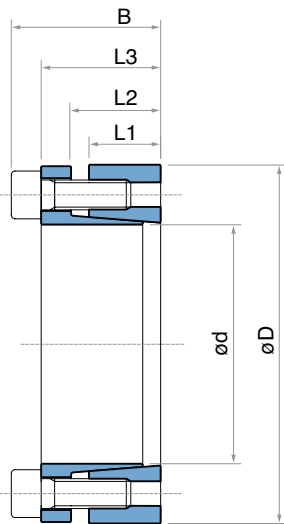

TLK 132

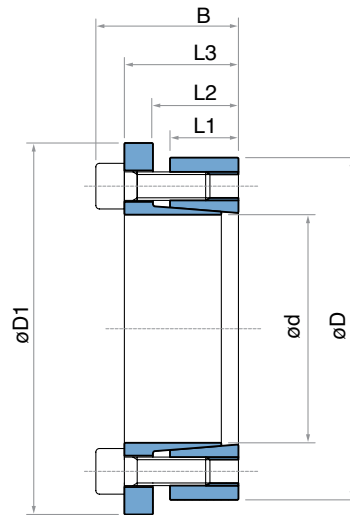

TLK 133

TLK 132 - TLK 133 DIMENSIONS

Dimensions					Only TLK 133	Tightening screws		TLK 132					TLK 133					
						DIN912 12.9	Tightening torque	Torque	Axial force	Surface pressures on		Weight	Axial Torque	Surface pressures on		Weight		
d x D mm	L1 mm	L2 mm	L3 mm	B mm	D1 mm	N° x Type	M _S (Nm) TLK 132	M _S (Nm) TLK 133	M _t Nm	F _{ax} KN	p _w N/mm ²			P _n N/mm ²	Kg		M _t Nm	F _{ax} KN
18 x 47	17	22	28	34	53	5 x M6	14	17	330	38	326	125	0,35	250	28	246	94	0,3
19 x 47	17	22	28	34	53	5 x M6	14	17	350	38	308	125	0,3	270	28	233	94	0,3
* 20 x 47	17	22	28	34	53	6 x M6	14	17	450	45	352	150	0,3	340	34	266	113	0,3
22 x 47	17	22	28	34	53	6 x M6	14	17	490	45	320	150	0,3	370	34	242	113	0,3
24 x 50	17	22	28	34	56	6 x M6	14	17	540	45	293	141	0,3	400	34	222	106	0,3
* 25 x 50	17	22	28	34	56	6 x M6	14	17	560	45	281	141	0,3	420	34	213	106	0,3
28 x 55	17	22	28	34	61	6 x M6	14	17	630	45	251	128	0,4	470	34	190	97	0,4
* 30 x 55	17	22	28	34	61	6 x M6	14	17	670	45	234	128	0,3	510	34	177	97	0,4
32 x 60	17	22	28	34	67	8 x M6	14	17	960	60	293	156	0,4	720	45	222	118	0,4
* 35 x 60	17	22	28	34	67	8 x M6	14	17	1050	60	268	156	0,4	790	45	203	118	0,4
38 x 65	17	22	28	34	72	8 x M6	14	17	1140	60	247	144	0,4	860	45	187	109	0,5
* 40 x 65	17	22	28	34	72	8 x M6	14	17	1200	60	234	144	0,4	900	45	177	109	0,5
42 x 75	20	25	33	41	82	8 x M8	35	41	2410	115	363	204	0,8	1760	84	265	149	0,8
* 45 x 75	20	25	33	41	82	8 x M8	35	41	2580	115	339	204	0,6	1890	84	248	149	0,7
48 x 80	20	25	33	41	87	8 x M8	35	41	2760	115	318	191	0,8	2010	84	232	139	0,8
* 50 x 80	20	25	33	41	87	8 x M8	35	41	2870	115	305	191	0,8	2100	84	223	139	0,8
55 x 85	20	25	33	41	92	8 x M8	35	41	3160	115	278	180	0,8	2310	84	203	131	0,9
* 60 x 90	20	25	33	41	97	8 x M8	35	41	3450	115	254	170	0,8	2520	84	186	124	0,9
65 x 95	20	25	33	41	102	9 x M8	35	41	4200	129	264	181	0,9	3070	95	193	132	1
* 70 x 110	24	30	40	50	117	8 x M10	70	83	6300	181	285	181	1,8	4670	133	211	134	1,9
75 x 115	24	30	40	50	122	8 x M10	70	83	6750	181	266	173	1,8	5000	133	197	128	2
* 80 x 120	24	30	40	50	127	8 x M10	70	83	7200	181	249	166	1,8	5330	133	184	123	2
85 x 125	24	30	40	50	132	10 x M10	70	83	9600	226	293	200	2	7080	167	217	147	2
* 90 x 130	24	30	40	50	137	10 x M10	70	83	10150	226	277	192	2,1	7500	167	205	142	2,2
95 x 135	24	30	40	50	142	10 x M10	70	83	10700	226	263	185	2,1	7920	167	194	137	2,3
* 100 x 145	26	32	44	56	152	8 x M12	125	145	13450	269	274	189	2,8	9710	194	198	137	3
110 x 155	26	32	44	56	162	8 x M12	125	145	14750	269	249	177	3	10700	194	180	128	3,2
120 x 165	26	32	44	56	172	9 x M12	125	145	18150	302	257	187	3,2	13100	219	186	135	3,4
130 x 180	34	40	54	66	187	12 x M12	125	145	26200	403	242	175	4,8	18950	291	175	126	5,2
140 x 190	34	40	54	68	197	9 x M14	190	230	27800	397	221	163	5,2	21000	300	167	123	5,4
150 x 200	34	40	54	68	207	10 x M14	190	230	33100	442	230	172	5,4	25000	333	173	130	5,7
160 x 210	34	40	54	68	217	12 x M14	190	230	42400	530	258	197	5,7	32000	400	195	149	6
170 x 225	44	50	64	78	232	12 x M14	190	230	45050	530	188	142	8	34000	400	142	107	8,3
180 x 235	44	50	64	78	242	12 x M14	190	230	47700	530	177	136	8,3	36000	400	134	103	8,8
190 x 250	44	50	64	78	257	15 x M14	190	230	62900	662	210	160	9,6	47500	500	159	121	10
200 x 260	44	50	64	78	267	15 x M14	190	230	66250	662	200	154	10	50000	500	151	116	10,5

* New standard.

NOTE: it is possible to reduce the screws tightening torque down to 60% of the values indicated in above table; as a result M_t, F_{ass}, P_w, P_n are reduced proportionally.

Tollok™ Locking Assemblies

TLK 200-NOT SELF-CENTERING

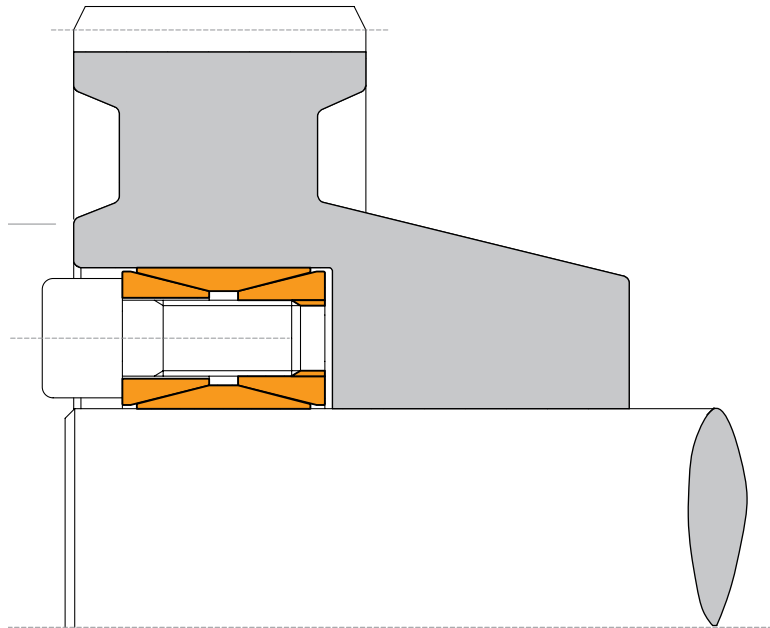

CHARACTERISTICS

- Medium-high torque
- Wide tolerances
- Easy availability
- Easy dismantling

INSTALLATION

Carefully clean the hub and shaft contact surfaces and apply a light oil film. Slide the locking assembly into the hub bore and insert the shaft. Tighten cadmium plated clamping screws until inner ring grips the shaft and the outer ring grips the hub bore then tighten gradually and regularly in crossed sequence all screws to reach the tightening torque M_s indicated in the table. The values M_t and F_{ax} indicated in the table are valid only in case of oil installation.

Do not use any oil with **molibdenum bisulphide** or high pressure additives and not grease.

DISMANTLING

By loosening all tightening screws the clamping unit is normally released. In case of difficulties slightly hammer the released screws to push back the rear pressure cone.

TOLERANCES, SURFACE FINISH

A good surface finish by machine tool is sufficient. Maximum allowable surface finish:

Rt max 16 μ m (Ra 3 μ m - Rz 13 μ m)

Maximum permissible tolerances:

h11 for shaft

H11 for hub

CENTERING

Mod. TLK 200 is not self-centering. The hub concentricity with respect to the shaft depends on the guide surface tolerance and its length.

AXIAL MOVEMENT

TLK 200: during screws tightening the hub has no axial movement with respect to the shaft.

DM HUB CALCULATION

The pressure P_n in the hub can be compared to the inside pressure on a thick hollow cylinder.

For DM calculation see page 30.

MT TRANSMISSIBLE

If two or more clamping unit are installed together, as a result of carried tests, the M_t transmissible shall be calculated as follow:

Nr. 1 TLK 200 $M_t = M_t \text{ cat.}$

Nr. 2 TLK 200 $M_t = M_t \text{ cat.} \cdot 1,9$

Nr. 3 TLK 200 $M_t = M_t \text{ cat.} \cdot 2,7$

Tollok™ Locking Assemblies

TLK 200-NOT SELF-CENTERING

TLK 200 DIMENSIONS

Dimensions				Shaft / Hub tolerances h11 / H11				Shaft / Hub tolerances h7 / H7		Tightening screws		Weight
				Torque	Axial force	Surface pressures on		Torque	Pressure on Hub	DIN912 12.9	Tightening torque	
M_t Nm	F_{ax} KN	p_w N/mm ²	p_s N/mm ²			M_t Nm	p_s N/mm ²					N° x Type
17 x 47	17	20	26	280	33	305	110	310	125	8 x M6	17	0,2
18 x 47	17	20	26	300	33	290	110	330	125	8 x M6	17	0,2
19 x 47	17	20	26	310	33	275	110	350	125	8 x M6	17	0,2
*20 x 47	17	20	26	330	33	260	110	370	125	8 x M6	17	0,2
22 x 47	17	20	26	360	33	235	110	410	125	8 x M6	17	0,2
24 x 50	17	20	26	390	33	215	105	440	115	8 x M6	17	0,3
*25 x 50	17	20	26	410	33	205	105	460	115	8 x M6	17	0,3
28 x 55	17	20	26	570	41	230	115	650	130	10 x M6	17	0,3
*30 x 55	17	20	26	610	41	215	115	690	130	10 x M6	17	0,3
32 x 60	17	20	26	780	49	240	130	890	145	12 x M6	17	0,3
*35 x 60	17	20	26	850	49	220	125	970	145	12 x M6	17	0,3
38 x 65	17	20	26	1070	57	235	135	1230	155	14 x M6	17	0,4
*40 x 65	17	20	26	1120	56	220	135	1300	155	14 x M6	17	0,3
42 x 75	20	24	32	1860	89	280	155	2170	185	12 x M8	41	0,6
*45 x 75	20	24	32	1990	89	260	155	2320	185	12 x M8	41	0,6
48 x 80	20	24	32	2120	88	245	145	2480	170	12 x M8	41	0,6
*50 x 80	20	24	32	2200	88	235	145	2580	170	12 x M8	41	0,6
55 x 85	20	24	32	2810	102	245	160	3310	190	14 x M8	41	0,6
*60 x 90	20	24	32	3050	102	225	150	3610	180	14 x M8	41	0,7
65 x 95	20	24	32	3770	116	235	160	4470	190	16 x M8	41	0,7
*70 x 110	24	28	38	5600	160	255	160	6700	190	14 x M10	83	1,3
75 x 115	24	28	38	5970	159	235	155	7170	185	14 x M10	83	1,3
*80 x 120	24	28	38	6330	158	220	145	7650	175	14 x M10	83	1,4
85 x 125	24	28	38	7660	180	235	160	9290	195	16 x M10	83	1,4
*90 x 130	24	28	38	8080	180	220	155	9840	185	16 x M10	83	1,5
95 x 135	24	28	38	9560	201	235	165	11600	200	18 x M10	83	1,6
*100 x 145	26	33	45	11300	227	230	160	13900	195	14 x M12	145	2,2
110 x 155	26	33	45	12400	226	210	150	15300	185	14 x M12	145	2,5
120 x 165	26	33	45	15400	258	220	160	19100	195	16 x M12	145	2,6
130 x 180	34	38	50	20800	320	190	140	25800	175	20 x M12	145	3,8
140 x 190	34	38	50	24500	351	195	145	30600	180	22 x M12	145	3,9
150 x 200	34	38	50	28500	381	200	150	35800	185	24 x M12	145	4
160 x 210	34	38	50	32900	411	200	155	41400	190	26 x M12	145	4,3
170 x 225	38	44	58	40400	476	195	150	51000	185	22 x M14	230	5,8
180 x 235	38	44	58	46500	518	200	155	59000	195	24 x M14	230	6
190 x 250	46	52	66	57200	602	185	140	72600	175	28 x M14	230	8,5
200 x 260	46	52	66	64200	643	185	145	81900	180	30 x M14	230	8,6
220 x 285	50	56	72	84500	769	185	145	108500	185	26 x M16	355	11
240 x 305	50	56	72	106000	884	195	155	136600	200	30 x M16	355	12
260 x 325	50	56	72	129300	995	205	160	167800	210	34 x M16	355	13
280 x 355	60	66	84	157200	1123	175	140	204600	180	32 x M18	485	19
300 x 375	60	66	84	188200	1255	185	150	246700	195	36 x M18	485	20
320 x 405	72	78	98	259400	1622	185	150	341400	195	36 x M20	690	30
340 x 425	72	78	98	274500	1615	175	140	362700	185	36 x M20	690	30

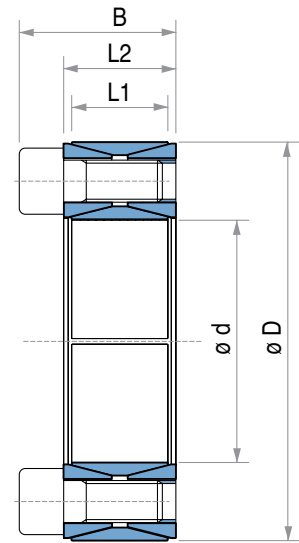

Tollok™ Locking Assemblies

TLK 300-NOT SELF-CENTERING

TLK 300 DIMENSIONS

dg	DIN912			C=0,140		
	Pv in N			Ms in Nm		
	8.8	10.9	12.9	8.8	10.9	12.9
M4	3900	5450	6550	2,9	4,1	4,9
M5	6350	8950	10700	6	8,5	10
M6	9000	12600	15100	10	14	17
[M7]	13200	18500	22200	16	23	28
M8	16500	23200	27900	25	35	41
[M9]	22000	30900	37100	36	51	61
M10	26200	36900	44300	49	69	83
M12	38300	54000	64500	86	120	145
M14	52500	74000	88500	135	190	230
M16	73000	102000	123000	210	295	355
M18	88000	124000	148000	290	405	485
M20	114000	160000	192000	410	580	690
M22	141000	199000	239000	550	780	930
M24	164000	230000	276000	710	1000	1200
M27	215000	302000	363000	1050	1500	1800
M30	262000	368000	442000	1450	2000	2400

Pa = N° of screws • Pv

Pt = see page 21

$$M_t \text{ transmissible} = \frac{Pa - Pt}{0,54} \cdot 0,12 \cdot \frac{d}{2000}$$

Screws center distance $l = D + 12 + dg$ (screws fixed on the hub) Flange thickness $Sf = dg \cdot 1,3$ (screws quality 8.8)

Screws center distance $l = d - 12 - dg$ (screws fixed on the shaft) Flange thickness $Sf = dg \cdot 1,8$ (screws quality 12.9)

Note: On request the type TLK 300 can be supplied also with split rings: therefore the transmissible torque M_t increases. Please contact our technical department.

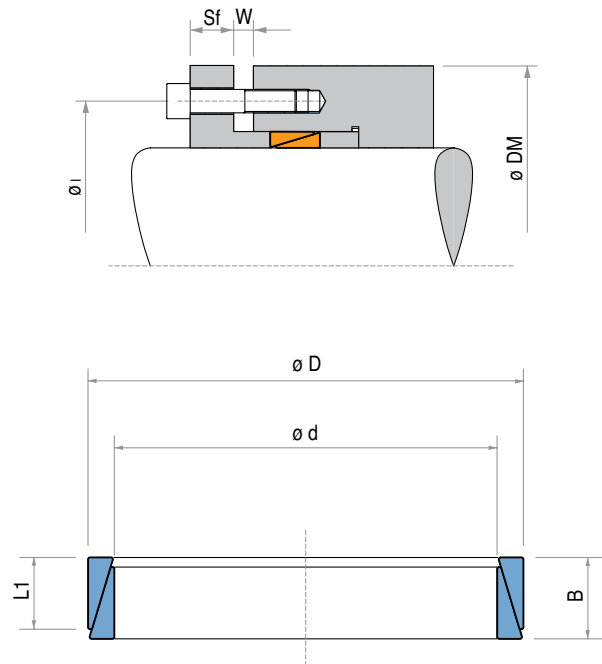

CHARACTERISTICS

- Medium low torque
- Restricted radial encumbrance
- Limited installation time
- Application economically advantageous

INSTALLATION

Carefully clean the hub and shaft contact surfaces and apply a light oil film. Slide the locking elements into the hub bore, insert the shaft and tighten gradually and regularly in crossed sequence all screws to reach the tightening torque M_s as indicated in the table. The values M_t and F_{ax} indicated in the table are valid only in case of oil installation.

Do not use any oil with **molybdenum bisulphide** or high pressure additives and not grease. Above substances notably reduce the friction coefficient.

DISMANTLING

By loosening all tightening screws the locking elements are released and the clamping is free. However in case of difficulties slightly hammer the hub.

TOLERANCES, SURFACE FINISH

A good surface finish by the machine tool is sufficient.

Maximum allowable surface finish:

Rt max 6 µm (Ra 1 µm - Rz 5 µm)

Maximum permissible tolerances:

shaft h6 - hub H7 (up to 40mm d. diameter)

shaft h8 - hub H8 (over 42mm d. diameter)

M_T TRANSMISSIBLE

Nr. 1 TLK 300 $M_t = M_t \text{ cat.}$

Nr. 2 TLK 300 $M_t = M_t \text{ cat.} \cdot 1,55$

Nr. 3 TLK 300 $M_t = M_t \text{ cat.} \cdot 1,85$

Nr. 4 TLK 300 $M_t = M_t \text{ cat.} \cdot 2,02$

DM HUB CALCULATION

The pressure P_n in the hub can be compared to the inside pressure on a thick hollow cylinder.

For DM calculation see page 30.

Tollok™ Locking Assemblies

TLK 300-NOT SELF-CENTERING

TLK 300 DIMENSIONS

Dimensions			Pre-load force	Total force	Torque	Axial force	Distance W before tightening				Spacer diameter		Surface pressures on		Weight
											Inside	Outside	Shaft	Hub	
d x D mm	B mm	L1 mm	Pt N	Pa N	Mt Nm	Fax KN	1 mm	2 mm	3 mm	4 mm	d1 mm	D1 mm	pw N/mm ²	Pn N/mm ²	Kg
9 x 12	4,5	3,7	7650	15600	8	1,76	2,5	2,5	3	4	9,1	11,9	140	105	0,000
* 10 x 13	4,5	3,7	7000	15600	10	1,91	2,5	2,5	3	4	10,1	12,9	135	105	0,002
* 12 x 15	4,5	3,7	7000	15600	11	1,91	2,5	2,5	3	4	12,1	14,9	115	90	0,002
13 x 16	4,5	3,7	6500	15600	13	2,02	2,5	2,5	3	4	13,1	15,9	110	90	0,000
* 14 x 18	6,3	5,3	11000	25400	22	3,18	3,5	3,5	4,5	5,5	14,1	17,9	115	90	0,005
* 15 x 19	6,3	5,3	10800	25400	24	3,24	3,5	3,5	4,5	5,5	15,1	18,9	110	85	0,005
16 x 20	6,3	5,3	10000	25400	27	3,42	3,5	3,5	4,5	5,5	16,1	19,9	105	85	0,006
17 x 21	6,3	5,3	9600	25400	30	3,51	3,5	3,5	4,5	5,5	17,1	20,9	105	85	0,006
18 x 22	6,3	5,3	9150	25400	32	3,61	3,5	3,5	4,5	5,5	18,1	21,9	100	80	0,007
19 x 24	6,3	5,3	12500	36000	49	5,22	3,5	3,5	4,5	5,5	19,2	23,8	140	110	0,007
* 20 x 25	6,3	5,3	12000	36000	53	5,33	3,5	3,5	4,5	5,5	20,2	24,8	135	105	0,009
22 x 26	6,3	5,3	9000	36000	66	6	3,5	3,5	4,5	5,5	22,2	25,8	135	115	0,007
24 x 28	6,3	5,3	8400	36000	73	6,13	3,5	3,5	4,5	5,5	24,2	27,8	130	110	0,008
* 25 x 30	6,3	5,3	10000	36000	72	5,77	3,5	3,5	4,5	5,5	25,2	29,8	115	95	0,009
28 x 32	6,3	5,3	7500	36000	88	6,33	3,5	3,5	4,5	5,5	28,2	31,8	115	100	0,010
* 30 x 35	6,3	5,3	8600	36000	91	6,08	3,5	3,5	4,5	5,5	30,2	34,8	100	85	0,011
32 x 36	6,3	5,3	7900	45000	131	8,24	3,5	3,5	4,5	5,5	32,2	35,8	130	115	0,011
* 35 x 40	7	6	10000	54000	171	9,77	3,5	3,5	4,5	5,5	35,2	39,8	125	110	0,016
36 x 42	7	6	11700	54000	169	9,39	3,5	3,5	4,5	5,5	36,2	41,8	115	100	0,019
38 x 44	7	6	11000	54000	181	9,55	3,5	3,5	4,5	5,5	38,2	43,8	110	95	0,021
* 40 x 45	8	6,6	13900	66000	231	11,57	3,5	4,5	5,5	6,5	40,2	44,8	115	105	0,021
42 x 48	8	6,6	15550	66000	235	11,22	3,5	4,5	5,5	6,5	42,2	47,8	110	95	0,026
* 45 x 52	10	8,6	28300	99000	353	15,71	3,5	4,5	5,5	6,5	45,2	51,8	105	95	0,045
48 x 55	10	8,6	24700	132000	572	23,84	3,5	4,5	5,5	6,5	48,2	54,8	155	135	0,043
* 50 x 57	10	8,6	23600	132000	602	24,08	3,5	4,5	5,5	6,5	50,2	56,8	150	130	0,045
55 x 62	10	8,6	21700	132000	670	24,35	3,5	4,5	5,5	6,5	55,2	61,8	140	125	0,049
* 60 x 68	12	10,4	27500	157200	860	28,6	3,5	4,5	5,5	7	60,2	67,8	125	110	0,070
65 x 73	12	10,4	25500	157200	950	29,2	3,5	4,5	5,5	7	65,2	72,8	115	100	0,090
* 70 x 79	14	12,2	31000	209600	1380	39,4	3,5	5	6,5	7,5	70,3	78,7	125	110	0,115
75 x 84	14	12,2	34700	209600	1450	38,6	3,5	5	6,5	7,5	75,3	83,7	115	100	0,120
* 80 x 91	17	15	48000	290000	2200	55	4	6	6,5	8	80,3	90,7	125	105	0,210
85 x 96	17	15	45500	305000	2400	56,4	4	6	6,5	8	85,3	95,7	120	105	0,210
* 90 x 101	17	15	43600	320000	2730	60,5	4	6	6,5	8	90,3	100,7	120	105	0,220
95 x 106	17	15	41300	330000	3050	64,2	4	6	6,5	8	95,3	105,7	120	110	0,230
* 100 x 114	21	18,7	61000	445000	4200	84	5	6	7	9	100,3	113,7	120	105	0,390
110 x 124	21	18,7	66000	485000	5150	93,6	5	6	7	9	110,3	123,7	120	105	0,420
120 x 134	21	18,7	60300	510000	6050	100,8	5	6	7	9	120,2	133,7	120	105	0,460
130 x 148	28	25,3	96300	765000	9600	147,6	5	7	9	11	130,4	147,6	120	105	0,860
140 x 158	28	25,3	89000	800500	11000	158,5	6	7	9	11	140,4	157,6	120	105	0,960
150 x 168	28	25,3	85000	860000	12900	172	6	7	8	11	150,4	167,6	120	105	1,000
160 x 178	28	25,3	78600	900000	14600	182,5	6	7	9	11	160,4	177,6	120	110	1,000
170 x 191	33	30	117400	1160000	19500	229	7	9	10	12	170,5	190,5	120	105	1,540
180 x 201	33	30	111300	1200000	21300	236	7	9	10	12	180,5	200,5	120	105	1,500
190 x 211	33	30	105000	1260000	24200	255	7	9	10	12	190,5	210,5	120	110	1,800
200 x 224	38	34,8	134200	1550000	31000	310	7	8	11	13	200,6	223,4	120	105	2,400
220 x 244	38	34,8	122100	1690000	38000	345	7	9	11	13	220,6	243,4	120	110	2,600
240 x 267	43	39,5	157400	2250000	51000	425	7	10	12	14	240,6	266,4	120	110	3,800
260 x 290	48	44	182000	2132000	56500	435	7	10	13	16	260,8	289,2	100	89	4,900
280 x 313	53	49	206000	2536000	72500	520	7	11	14	17	280,8	312,2	100	89	6,400
300 x 333	53	49	214000	2704000	83000	555	7	11	14	17	300,8	332,2	100	89	6,800
320 x 360	65	59	292000	3492000	114000	710	10	15	20	25	321,0	359,0	100	89	11,000
340 x 380	65	59	272000	3672000	128500	755	10	15	20	25	341,0	379,0	100	89	11,500

* New standard.

For larger diameter or inch series please contact us.

Tollok™ Locking Assemblies

TLK 350-SELF-CENTERING

TLK 350 DIMENSIONS

Dimensions			Torque	Axial force		Surface pressures on		Tightening screws		Weight
						Shaft	Hub	DIN912 12.9	Tightening torque	
d x D mm	L1 mm	L2 mm	B mm	M _t Nm	F _{ax} KN	P _w N/mm ²	P _n N/mm ²	N° x Type	M _s Nm	Kg
6 x 16	10,5	11	13,5	9	3,0	184	69	3 x M2,5	1,2	0,012
7 x 17	10,5	11	13,5	11	3,0	157	65	3 x M2,5	1,2	0,013
8 x 18	10,5	11	13,5	12	3,0	138	61	3 x M2,5	1,2	0,015
9 x 20	12,5	13	15,5	18	4,0	138	62	4 x M2,5	1,2	0,020
* 10 x 20	12,5	13	15,5	20	4,0	124	62	4 x M2,5	1,2	0,019
11 x 22	12,5	13	15,5	22	4,0	113	56	4 x M2,5	1,2	0,024
* 12 x 22	12,5	13	15,5	24	4,0	104	56	4 x M2,5	1,2	0,022
* 14 x 26	16,5	17	20	42	6,0	99	53	4 x M3	2,1	0,039
* 15 x 28	16,5	17	20	44	6,0	93	50	4 x M3	2,1	0,044
16 x 32	16,5	17	21	83	10,4	152	76	4 x M4	4,9	0,067
17 x 35	20,5	21	25	88	10,4	116	56	4 x M4	4,9	0,090
18 x 35	20,5	21	25	93	10,4	109	56	4 x M4	4,9	0,087
19 x 35	20,5	21	25	99	10,4	104	56	4 x M4	4,9	0,083
* 20 x 38	20,5	21	26	170	17,0	161	85	4 x M5	10	0,100
22 x 40	20,5	21	26	187	17,0	146	80	4 x M5	10	0,110
24 x 47	25	26	32	287	24,0	153	78	4 x M6	17	0,200
* 25 x 47	25	26	32	299	24,0	147	78	4 x M6	17	0,190
28 x 50	25	26	32	503	36,0	196	110	6 x M6	17	0,220
* 30 x 55	25	26	32	539	36,0	183	100	6 x M6	17	0,270
32 x 55	25	26	32	575	36,0	172	100	6 x M6	17	0,250
* 35 x 60	30	31	37	838	48,0	176	102	8 x M6	17	0,360
38 x 65	30	31	37	910	48,0	162	95	8 x M6	17	0,430
* 40 x 65	30	31	37	958	48,0	154	95	8 x M6	17	0,400
42 x 75	35	36	44	1394	66,3	175	98	6 x M8	41	0,670
* 45 x 75	35	36	44	1493	66,3	163	98	6 x M8	41	0,630
48 x 80	35	36	44	2124	88,5	204	122	8 x M8	41	0,740
* 50 x 80	35	36	44	2212	88,5	196	122	8 x M8	41	0,700

* New standard.

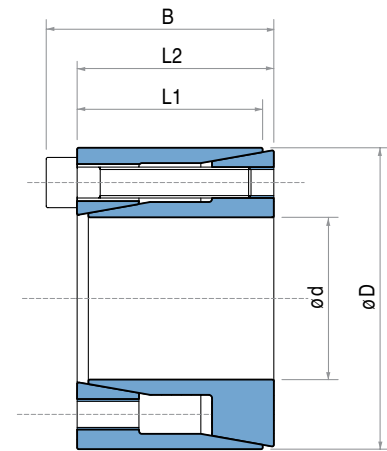

CHARACTERISTICS

- Medium-high torque
- Easy mounting
- Limited installation time
- Few clamping screws

INSTALLATION

Carefully clean the hub and shaft contact surfaces and apply a light oil film. Slide the locking assembly into the hub bore, insert the shaft and tighten gradually and regularly in crossed sequence all screws to reach the tightening torque M_s as indicated in the table. The values M_t and F_{ax} indicated in the table are valid only in case of oil installation.

Do not use any oil with **molibdenum bisulphide** or high pressure additives and not grease. Above substances notably reduce the friction coefficient.

DISMANTLING

Loosen the clamping screws. Insert the screws into the dismantling threading and tighten gradually and regularly in crossed sequence until the back cone is released. If the element is to be reused, relubricate both screws and threads.

TOLERANCES, SURFACE FINISH

A good surface finish by the machine tool is sufficient.

Maximum allowable surface finish:

Rt max 16 μm (Ra 3 μm - Rz 13 μm)

Maximum permissible tolerances:

h8 for shaft

H8 for hub

AXIAL MOVEMENT

TLK 350: during screws tightening the hub has a slight axial movement with respect to the shaft.

DM hub calculation

The pressure P_n in the hub can be compared to the inside pressure on a thick hollow cylinder.

For DM calculation see page 30.

Tollok™ Locking Assemblies

TLK 400-Self-Centering Patented

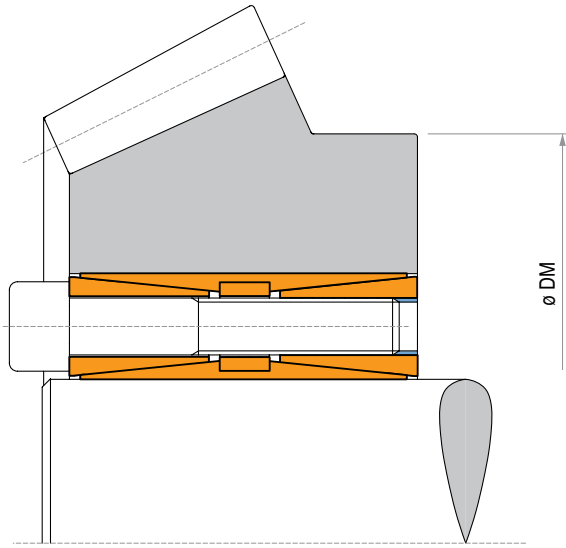

CHARACTERISTICS

- Very high torques
- Capacity to withstand bending moments
- Even pressures distribution
- No shaft-hub axial movement

INSTALLATION

Carefully clean the hub and shaft contact surfaces and apply a light oil film. Slide the locking assembly into the hub bore and insert the shaft. Tighten gradually and regularly in crossed sequence all screws up to 50% of the M_s value indicated in the table. Repeat the same operation by tightening all screws at the M_s torque indicated in the table.

Starting from the last tightened screw, check, in continuous sequence, that all the screws are tightened at the tightening torque M_s indicated. Repeat this procedure maximum twice. After this control any further operation is needed.

Do not use any oil with **molybdenum bisulphide** or high pressure additives and not grease. Above substances notably reduce the friction coefficient.

DISMANTLING

Loosen the clamping screws. Insert the screws into the dismantling threads of the front cone and tighten them gradually in crossed sequence up to 50% of the M_s value indicated in the table. Repeat the same operation by tightening the screws at the tightening torque M_s indicated in the table. When the front cone is loose, to release the rear cone, insert the screws in the middle ring, and repeat the same operation of the upper ring.

TOLERANCES, SURFACE FINISH

A good surface finish by the machine tool is sufficient. Maximum allowable surface finish:

Rt max 16 μm (Ra 3 μm - Rz 13 μm)

Maximum permissible tolerances:

h8 for shaft

H8 for hub

AXIAL MOVEMENT

During screws tightening the hub has no axial movement with respect to the shaft.

DM hub calculation

For DM calculation see page 30.

Tollok™ Locking Assemblies

TLK 400-Self-Centering

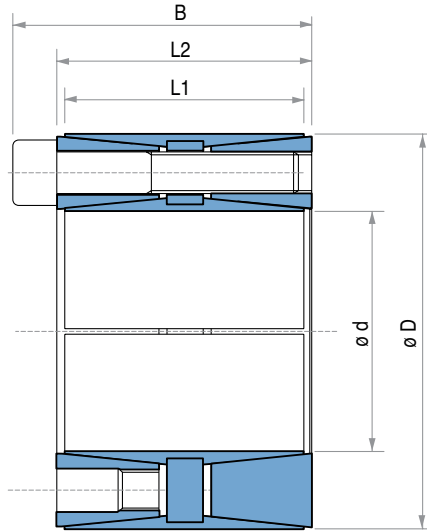

TLK 400 DIMENSIONS

Dimensions				Tightening screws		Torque	Axial force	Surface pressures on		Weight
				DIN912 12.9	Tightening torque			Shaft	Hub	
d x D mm	L1 mm	L2 mm	B mm	N° x Type	M _s Nm	M _t Nm	F _{ax} KN	p _w N/mm ²	p _n N/mm ²	Kg
* 45 x 75	56	64	72	8 x M8	41	3460	155	165	100	1,3
48 x 80	56	64	72	8 x M8	41	3680	155	150	95	1,5
* 50 x 80	56	64	72	8 x M8	41	3820	155	147	95	1,4
* 55 x 85	56	64	72	8 x M8	41	4260	155	135	85	1,5
* 60 x 90	56	64	72	10 x M8	41	5820	190	155	100	1,5
* 65 x 95	56	64	72	10 x M8	41	6270	190	140	95	1,6
* 70 x 110	70	78	88	10 x M10	83	10730	305	170	105	3,0
* 75 x 115	70	78	88	10 x M10	83	11540	305	155	100	3,1
* 80 x 120	70	78	88	12 x M10	83	14700	369	175	115	3,5
* 85 x 125	70	78	88	12 x M10	83	15700	369	165	110	3,5
* 90 x 130	70	78	88	12 x M10	83	16610	370	157	106	3,8
* 95 x 135	70	78	88	12 x M10	83	17530	370	150	102	4,0
* 100 x 145	90	100	112	12 x M12	145	26900	538	160	110	6,0
* 110 x 155	90	100	112	12 x M12	145	29530	538	143	102	6,2
* 120 x 165	90	100	112	14 x M12	145	37610	628	154	112	6,8
* 130 x 180	104	116	130	12 x M14	230	48000	738	143	106	9,8
* 140 x 190	104	116	130	14 x M14	230	60290	861	160	117	10,2
* 150 x 200	104	116	130	16 x M14	230	73800	985	165	125	10,9
160 x 210	104	116	130	16 x M14	230	78770	983	155	118	11,5
170 x 225	134	146	162	14 x M16	355	101730	1197	140	108	17,2
180 x 235	134	146	162	16 x M16	355	123200	1369	150	115	18,0
190 x 250	134	146	162	16 x M16	355	129880	1368	141	110	21,5
200 x 260	134	146	162	16 x M16	355	136840	1368	137	104	22,0
220 x 285	134	146	162	20 x M16	355	188000	1710	155	120	25,0
240 x 305	134	146	162	22 x M16	355	225000	1880	155	120	27,0
260 x 325	134	146	162	22 x M16	355	244000	1880	155	115	30,0
280 x 355	165	177	197	20 x M20	690	373000	2670	145	120	46,0
300 x 375	165	177	197	22 x M20	690	440000	2930	155	125	50,0
320 x 405	165	177	197	22 x M20	690	470000	2930	145	115	60,0
340 x 425	165	177	197	24 x M20	690	544000	3200	150	120	65,0

* New standard.

For larger diameter or inch series please contact us.

NOTE: it is possible to reduce the screws tightening torque down to 60% of the values indicated in above table; as a result M_t, F_{ax}, P_w, P_n are reduced proportionally.

Tollok™ Locking Assemblies

TLK 450-Self-Centering

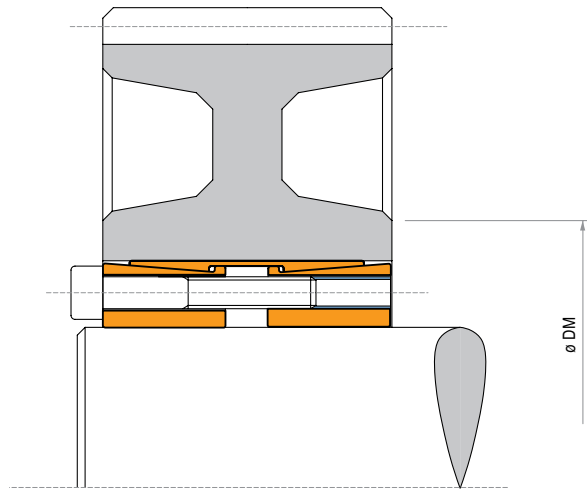

CHARACTERISTICS

- Very high torques
- Capacity to withstand bending moments
- Standard sizes

INSTALLATION

Carefully clean the hub and shaft contact surfaces and apply a light oil film. Slide the locking assembly into the hub bore and insert the shaft. Tighten gradually and regularly in crossed sequence all screws up to 50% of the M_s value indicated in the table. Repeat the same operation by tightening all screws at the M_s torque indicated in the table.

Starting from the last tightened screw, check, in continuous sequence, that all the screws are tightened at the tightening torque M_s indicated. Repeat this procedure maximum twice. After this control any further operation is needed.

Do not use any oil with **molybdenum bisulphide** or high pressure additives and not grease. Above substances notably reduce the friction coefficient.

DISMANTLING

Loosen the clamping screws. Insert the screws into the dismantling threads of the front cone and tighten them gradually in crossed sequence up to 50% of the M_s value indicated in the table. Repeat the same operation by tightening the screws at the tightening torque M_s indicated in the table.

When the front cone is loose, to release the rear cone:

TLK 450: keep tightening the screws and repeat the sequence above.

TOLERANCES, SURFACE FINISH

A good surface finish by the machine tool is sufficient. Maximum allowable surface finish:

Rt max 16 μm (Ra 3 μm - Rz 13 μm)

Maximum permissible tolerances:

h8 for shaft

H8 for hub

DM hub calculation

For DM calculation see page 30.

Tollok™ Locking Assemblies

TLK 450-Self-Centering

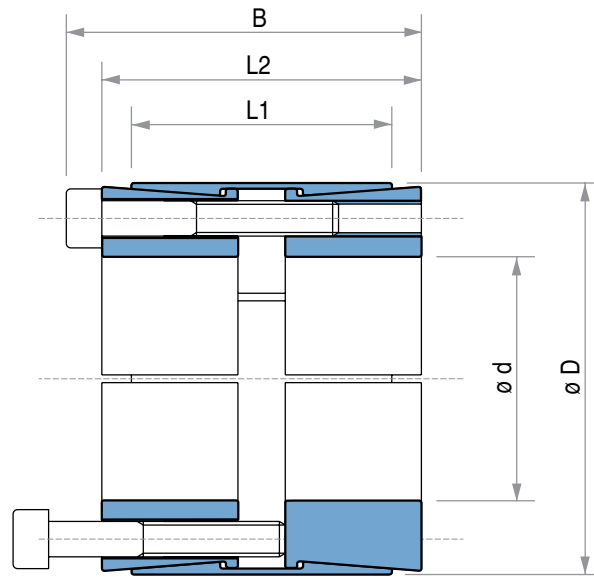

TLK 450 DIMENSIONS

Dimensions				Tightening screws		Torque	Axial force	Surface pressures on		Weight
				DIN912 12.9	Tightening torque			Shaft	Hub	
d x D mm	L1 mm	L2 mm	B mm	N° x Type	M _s Nm	M _t Nm	F _{ax} KN	p _w N/mm ²	P _n N/mm ²	Kg
* 25 x 50	39	45	51	8 x M6	17	950	76	245	122	0,5
28 x 55	39	45	51	8 x M6	17	1070	76	219	111	0,6
* 30 x 55	39	45	51	8 x M6	17	1150	76	204	111	0,6
* 35 x 60	39	45	51	8 x M6	17	1340	76	175	102	0,7
38 x 65	39	45	51	8 x M6	17	1450	76	161	94	0,7
* 40 x 65	39	45	51	8 x M6	17	1530	76	153	94	0,7
42 x 75	56	64	72	8 x M8	41	2970	141	188	105	1,0
* 45 x 75	56	64	72	8 x M8	41	3150	141	175	105	0,9
48 x 80	56	64	72	8 x M8	41	4000	166	164	98	1,4
* 50 x 80	56	64	72	8 x M8	41	4150	166	158	98	1,3
* 55 x 85	56	64	72	8 x M8	41	4550	166	143	93	1,5
* 60 x 90	56	64	72	10 x M8	41	6200	207	164	109	1,6
* 65 x 95	56	64	72	10 x M8	41	6750	207	152	104	1,8
* 70 x 110	70	78	88	10 x M10	83	11550	330	179	114	3,0
* 75 x 115	70	78	88	10 x M10	83	12350	330	167	109	3,3
* 80 x 120	70	78	88	12 x M10	83	15800	396	188	125	3,5
* 85 x 125	70	78	88	12 x M10	83	16800	396	177	120	3,7
* 90 x 130	70	78	88	12 x M10	83	17800	396	167	115	3,8
* 95 x 135	70	78	88	12 x M10	83	18800	396	158	111	5,0
* 100 x 145	90	100	112	12 x M12	145	28800	576	170	117	6,0
* 110 x 155	90	100	112	12 x M12	145	31700	576	155	110	6,2
* 120 x 165	90	100	112	14 x M12	145	40300	673	165	120	7,2
* 130 x 180	104	116	130	12 x M14	230	51400	791	155	112	10,0
* 140 x 190	104	116	130	14 x M14	230	64600	923	168	124	10,2
* 150 x 200	104	116	130	16 x M14	230	79100	1055	179	135	10,8
160 x 210	104	116	130	16 x M14	230	84400	1055	168	128	11,5
170 x 225	134	146	162	14 x M16	355	109000	1283	149	113	17,0
180 x 235	134	146	162	16 x M16	355	132000	1466	161	124	18,5
190 x 250	134	146	162	16 x M16	355	139000	1466	153	116	21,5
200 x 260	134	146	162	16 x M16	355	146500	1466	145	112	22,0
220 x 285	134	146	162	20 x M16	355	201500	1833	165	127	25,0
240 x 305	134	146	162	22 x M16	355	242000	2017	166	131	27,0
260 x 325	134	146	162	22 x M16	355	262000	2017	154	123	30,0
280 x 355	165	177	197	20 x M20	690	400000	2862	164	130	46,0
300 x 375	165	177	197	22 x M20	690	472000	3148	169	135	50,0
320 x 405	165	177	197	22 x M20	690	503500	3148	158	125	60,0
340 x 425	165	177	197	24 x M20	690	583500	3434	162	130	65,0

* New standard.

NOTE: it is possible to reduce the screws tightening torque down to 60% of the values indicated in above table; as a result M_s, F_{ax}, P_w, P_n are reduced proportionally.

Tollok™ Locking Assemblies

TLK 500-RIGID COUPLING

TLK 500 DIMENSIONS

Dimensions			Torque	Axial force	Tightening Screws		Weight
					DIN912 12.9	Tightening torque	
d x D mm	L mm	B mm	M _t Nm	F _{ax} N° x Type	N° x Type	M _s Nm	Kg
17 x 50	50	56	200	24	4 x M6	17	0,5
18 x 50	50	56	220	24	4 x M6	17	0,5
19 x 50	50	56	230	24	4 x M6	17	0,5
*20 x 50	50	56	240	24	4 x M6	17	0,5
22 x 55	60	66	260	24	4 x M6	17	0,6
24 x 55	60	66	290	24	4 x M6	17	0,6
*25 x 55	60	66	450	36	6 x M6	17	0,6
28 x 60	60	66	510	36	6 x M6	17	0,7
*30 x 60	60	66	550	36	6 x M6	17	0,7
32 x 75	60	68	720	45	4 x M8	41	1,3
*35 x 75	75	83	790	45	4 x M8	41	1,3
38 x 75	75	83	850	45	4 x M8	41	1,3
*40 x 75	75	83	900	45	4 x M8	41	1,3
42 x 90	75	83	1400	67	6 x M8	41	2,8
45 x 90	85	93	1520	67	6 x M8	41	2,5
48 x 90	85	93	1620	67	6 x M8	41	2,4
*50 x 90	85	93	1690	67	6 x M8	41	2,3
55 x 105	85	93	2470	90	8 x M8	41	3,3
*60 x 105	85	93	2710	90	8 x M8	41	3,2
65 x 105	85	93	2930	90	8 x M8	41	3,0
70 x 125	100	110	3770	107	6 x M10	83	5,4
75 x 125	100	110	4030	107	6 x M10	83	5,0
80 x 125	100	110	4300	107	6 x M10	83	4,7

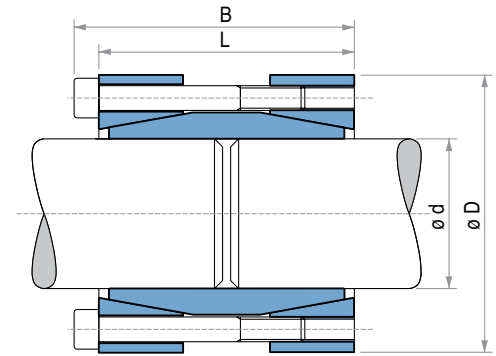

Standard version

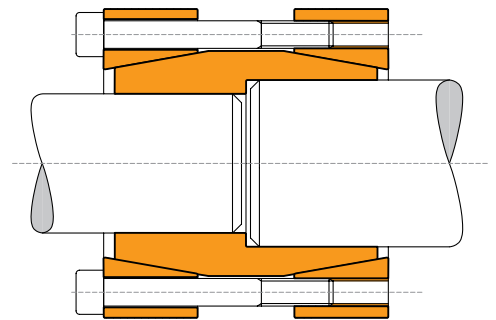

Double diameter versions are available

CHARACTERISTICS

- Medium high torque
- Restricted number of tightening screws
- Easy installation
- Application economically advantageous

INSTALLATION

Carefully clean the shafts contact surfaces. Fit the rigid coupling at the end of the connecting shafts. Tighten gradually and regularly in crossed sequence all screws to reach the tightening torque **M_s** indicated on the table.

DISMANTLING

By loosening all tightening screws the clamping cones are normally released. However in case of difficulties slightly hammer the released screws in a way to push back the rear pressure cone.

TOLERANCES, SURFACE FINISH

A good surface finish by the machine tool is sufficient. Maximum allowable surface finish:

Rt max 16 µm (Ra 3 µm - Rz 13 µm)

Maximum permissible tolerances:

h8 for shaft

Tollok™ Locking Assemblies

TLK 603-SHRINK DISCS

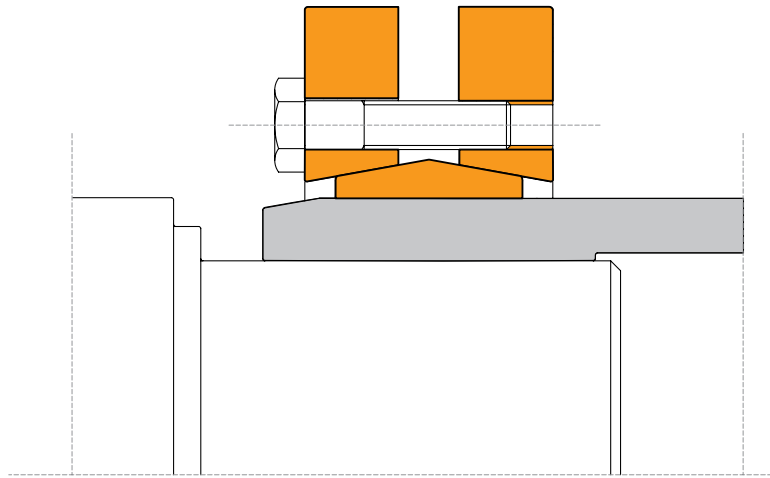

CHARACTERISTICS

- Medium-high torque
- No shaft-hub axial movement
- Limited installation time
- Quick dismantling

INSTALLATION

Carefully clean the hub and shaft contact surfaces. Slide the shrink disc outside the hollow shaft. Tighten gradually and regularly in continuous sequence all screws to reach the tightening torque M_s indicated in the table.

To reach the required tightening torque M_s it is necessary to repeat the procedure more than once.

Do not use **molybdenum disulfide** in the hub and shaft contact surfaces.

DISMANTLING

Loosen the clamping screws in a continuous and gradual sequence. Do not remove screws from threads. Normally with this operation the shrink disc is released.

In case of reuse, apply a solid lubricant (that can guarantee a friction coefficient equal to 0,04) in the screws and in the tapered surfaces.

TOLERANCES, SURFACE FINISH

A good surface finish by the machine tool is sufficient. Maximum allowable surface finish:

Rt max 16 μm (Ra 3 μm - Rz 13 μm)

Maximum permissible tolerances:

d = h8 for shaft

Dw diameter tolerances

From 18 mm to 30 mm dw H6/j6

From 30 mm to 50 mm dw H6/h6

From 50 mm to 80 mm dw H6/g6

From 80 mm to 500 mm dw H7/g6

AXIAL MOVEMENT

During screws tightening the hub has no axial movement with respect to the shaft.

Tollok™ Locking Assemblies

TLK 603-SHRINK DISCS-STANDARD VERSION

TLK 603 DIMENSIONS

Type	Shaft diameter	Torque	Axial force	Dimensions					Tightening screws		Weight
									DIN931 10.9	Tightening torque	
d mm	dw mm	M _t Nm	F _{ax} KN	D mm	l mm	L mm	d1 mm	e mm	N° x Type	M _s Nm	Kg
14	11	30	6	38	7	11	23	2	4 x M5*	4	0,1
	12	50	9								
16	13	70	10	41	11	15	26	2	5 x M5*	4	0,1
	14	90	13								
24	19	170	25	50	14	19,5	36	2,75	6 x M5*	4	0,2
	20	210	27								
30	21	250	29	60	16	21,5	44	2,75	7 x M5*	4	0,3
	24	300	29								
36	25	340	31	72	18	23,5	52	2,75	5 x M6	12	0,4
	26	380	33								
44	28	440	50	80	20	25,5	61	2,75	7 x M6	12	0,6
	30	570	58								
50	31	630	58	90	22	27,5	70	2,75	8 x M6	12	0,8
	32	620	64								
55	35	780	74	100	23	30,5	75	3,75	8 x M6	12	1,1
	36	860	77								
62	38	940	79	110	23	30,5	86	3,75	10 x M6	12	1,3
	40	1160	86								
68	42	1380	92	115	23	30,5	86	3,75	10 x M6	12	1,4
	42	1160	79								
75	45	1520	88	138	25	32,5	100	3,75	7 x M8	30	1,7
	48	1880	97								
80	48	1850	100	145	25	32,5	100	3,75	7 x M8	30	1,9
	50	2200	111								
85	50	2200	111	155	30	39	114	4,5	10 x M8	30	3,5
	52	2400	117								
90	50	2000	97	155	30	39	114	4,5	10 x M8	30	3,3
	55	2500	106								
100	60	3150	120	170	34	44	124	5	12 x M8	30	4,7
	55	2500	119								
110	60	3200	124	185	39	50	136	5,5	9 x M10	59	5,9
	65	3950	155								
115	60	3200	124	188	39	50	141	5,5	9 x M10	59	5,5
	65	3900	140								
120	65	4800	175	215	42	54	160	6	12 x M10	59	9
	70	4600	158								
125	65	4800	175	215	42	54	160	6	12 x M10	59	8,3
	70	4600	158								
130	70	6100	195	230	46	60,5	175	7,25	10 x M12	100	10
	75	7400	216								
140	65	4750	170	265	50	64,5	192	7,25	12 x M12	100	15
	70	6000	190								
155	75	7250	210	265	50	64,5	192	7,25	12 x M12	100	14,5
	75	7250	210								
160	70	6900	195	290	56	71	210	7,5	8 x M16	250	22
	80	9000	240								
165	75	7200	229	310	60	75	220	7,5	8 x M16	250	22
	80	9000	240								
165	80	10800	262	310	60	75	220	7,5	8 x M16	250	22
	85	12600	300								
165	80	7400	235	310	60	75	220	7,5	8 x M16	250	22
	85	12600	300								
165	80	10600	285	310	60	75	220	7,5	8 x M16	250	22
	85	12600	300								
165	85	13300	314	310	60	75	220	7,5	8 x M16	250	22
	90	14500	340								
165	85	11000	296	310	60	75	220	7,5	8 x M16	250	22
	90	14500	340								
165	90	13000	324	310	60	75	220	7,5	8 x M16	250	22
	95	15000	352								
165	90	11300	304	310	60	75	220	7,5	8 x M16	250	22
	95	15000	352								
165	90	13300	333	310	60	75	220	7,5	8 x M16	250	22
	100	15400	362								
165	95	15100	367	310	60	75	220	7,5	8 x M16	250	22
	100	15400	362								
165	95	15100	367	310	60	75	220	7,5	8 x M16	250	22
	100	15400	362								
165	95	15100	367	310	60	75	220	7,5	8 x M16	250	22
	100	15400	362								
165	95	15100	367	310	60	75	220	7,5	8 x M16	250	22
	100	15400	362								
165	95	15100	367	310	60	75	220	7,5	8 x M16	250	22
	100	15400	362								
165	95	15100	367	310	60	75	220	7,5	8 x M16	250	22
	100	15400	362								
165	95	15100	367	310	60	75	220	7,5	8 x M16	250	22
	100	15400	362								
165	95	15100	367	310	60	75	220	7,5	8 x M16	250	22
	100	15400	362								
165	95	15100	367	310	60	75	220	7,5	8 x M16	250	22
	100	15400	362								
165	95	15100	367	310	60	75	220	7,5	8 x M16	250	22
	100	15400	362								
165	95	15100	367	310	60	75	220	7,5	8 x M16	250	22
	100	15400	362								
165	95	15100	367	310	60	75	220	7,5	8 x M16	250	22
	100	15400	362								
165	95	15100	367	310	60	75	220	7,5	8 x M16	250	22
	100	15400	362								
165	95	15100	367	310	60	75	220	7,5	8 x M16	250	22
	100	15400	362								
165	95	15100	367	310	60	75	220	7,5	8 x M16	250	22
	100	15400	362								
165	95	15100	367	310	60	75	220	7,5	8 x M16	250	22
	100	15400	362								
165	95	15100	367	310	60	75	220	7,5	8 x M16	250	22
	100	15400	362								
165	95	15100	367	310	60	75	220	7,5	8 x M16	250	22
	100	15400	362								
165	95	15100	367	310	60	75	220	7,5	8 x M16	250	22
	100	15400	362								
165	95	15100	367	310	60	75	220	7,5	8 x M16	250	22
	100	15400	362								
165	95	15100	367	310	60	75	220	7,5	8 x M16	250	22
	100	15400	362								
165	95	15100	367	310	60	75	220	7,5	8 x M16	250	22
	100	15400	362								
165	95	15100	367	310	60	75	220	7,5	8 x M16	250	22
	100	15400	362								
165	95	15100	367	310	60	75	220	7,5	8 x M16	250	22
	100	15400	362								
165	95	15100	367	310	60	75	220	7,5	8 x M16	250	22
	100	15400	362								
165	95	15100	367	310	60	75	220	7,5	8 x M16	250	22
	100	15400	362								
165	95	15100	367	310	60	75	220	7,5	8 x M16	250	22
	100	15400	362								
165	95	15100	367	310	60	75	220	7,5	8 x M16	250	22
	100	15400	362								
165	95	15100	367	310	60	75	220	7,5	8 x M16	250	22
	100	15400	362								
165	95	15100	367	310	60	75	220	7,5	8 x M16	250	22
	100	15400	362								
165	95	15100	367	310	60	75	220	7,5	8 x M16	250	22
	100	15400	362								
165	95	15100	367	310	60	75	220	7,5	8 x M16	250	22
	100	15400	362								
165	95	15100	367	310	60	75	220	7,5	8 x M16	250	22
	100	15400	362								
165	95	15100	367	310	60	75	220	7,5	8 x M16	250	22
	100	15400	362								
165	95	15100	367	310	60	75	220	7,5	8 x M16	250	22
	100	15400	362								
165	95	15100	367	310	60	75	220	7,5	8 x M16	250	22
	100	15400	362								
165	95	15100	367	310	60	75	220	7,5	8 x M16	250	22
	100	15400	362								
165	95	15100	367	310	60	75	220	7,5	8 x M16	250	22
	100	15400	362								
165	95	15100	367	310	60	75	220	7,5	8 x M16	250	22
	100	15400	362								
165	95	15100	367	310	60	75	220	7,5	8 x M16	250	22
	100	15400	362								
165	95	15100	367	310	60	75	220	7,5	8 x M16	250	22
	100	15400	362								
165	95	15100	367	310	60	75	220	7,5	8 x M16	250	22
	100	15400	362								
165	95	15100	367	310	60	75	220	7,5	8 x M16	250	22
	100	15400	362								
165	95	15100	367	310	60	75	220	7,5	8 x M16	250	22
	100	15400	362								
165	9										

Tollok™ Locking Assemblies

TLK 603-SHRINK DISCS-STANDARD VERSION

TLK 603 DIMENSIONS

Type	Shaft diameter	Torque	Axial force	Dimensions					Tightening screws		Weight
									DIN931 10.9	Tightening torque	
d mm	dw mm	M _t Nm	F _{ax} KN	D mm	l mm	L mm	d1 mm	e mm	N° x Type	M _s Nm	Kg
170	120	31900	610								
	125	36000	640	290	56	71	210	7,5	8 x M16	250	21
	130	40100	670								
	125	36000	605								
175	130	41000	639	300	56	71	220	7,5	8 x M16	250	22
	135	45000	675								
	130	37000	800								
180	135	42200	840	300	56	71	220	7,5	8 x M16	250	21
	140	46300	885								
	135	52000	778								
185	140	57000	819	330	71	86	236	7,5	10 x M16	250	37
	145	62000	861								
	140	53500	800								
190	145	58700	840	330	71	86	236	7,5	10 x M16	250	36
	150	63800	885								
	140	65000	933								
195	150	76000	1025	350	71	86	246	7,5	12 x M16	250	41
	155	81500	1071								
	150	74000	990								
200	155	80000	1035	350	71	86	246	7,5	12 x M16	250	41
	160	86000	1080								
	160	95000	1190								
220	165	102000	1239	370	88	104	270	8	15 x M16	250	54
	170	110000	1290								
	170	120000	1464								
240	180	138000	1576	405	92	109	295	8,5	12 x M20	490	67
	190	156000	1675								
	190	164000	1760								
260	200	184000	1880	430	103	120	321	8,5	14 x M20	490	82
	210	205000	2010								
	210	217000	2090								
280	220	244000	2220	460	114	134	346	10	16 x M20	490	102
	230	270000	2350								
	230	275000	2431								
300	240	295000	2567	485	122	142	364	10	18 x M20	490	118
	245	315000	2636								
	240	312000	2647								
320	250	340000	2786	520	122	142	386	10	20 x M20	490	131
	260	374000	2900								
	250	390000	3119								
340	260	422500	3249	570	134	156	408	11	24 x M20	490	186
	270	460000	3400								
	270	442000	3276								
350	280	480000	3430	580	140	162	432	11	24 x M20	490	195
	285	500000	3500								

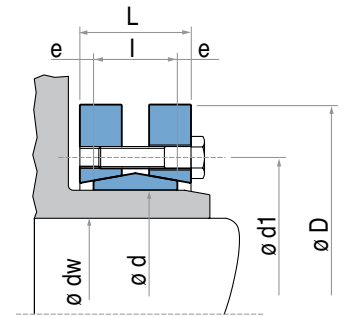

Tollok™ Locking Assemblies

SPECIAL APPLICATIONS-SHRINK DISCS

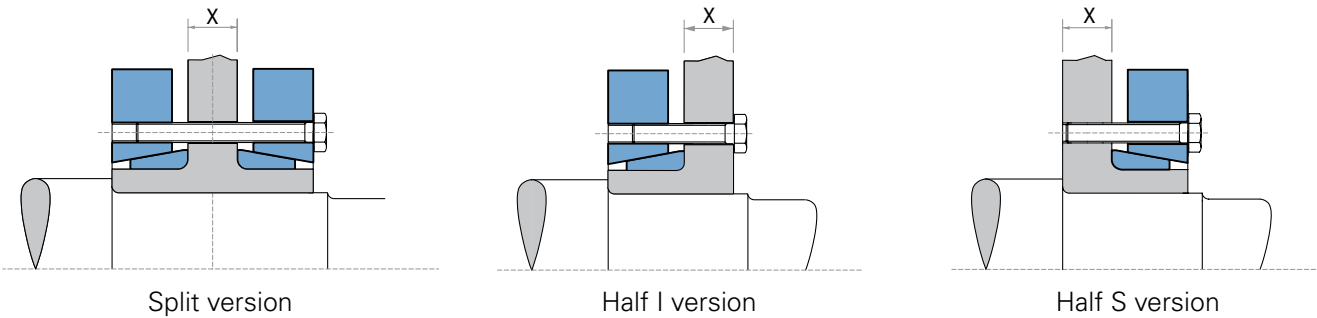

When ordering please specify X dimension

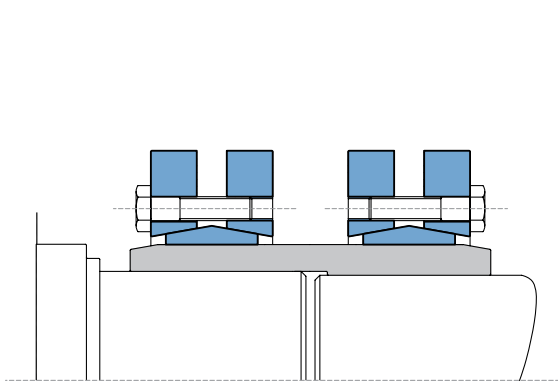

Use of model TLK 603 as coupling between different size shafts

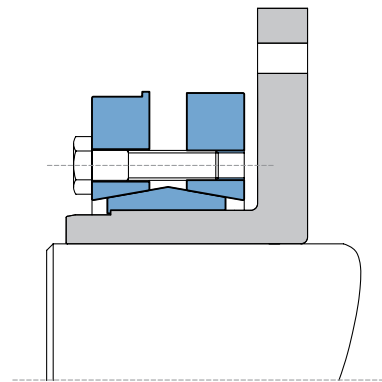

Special version equipped with housing for brake

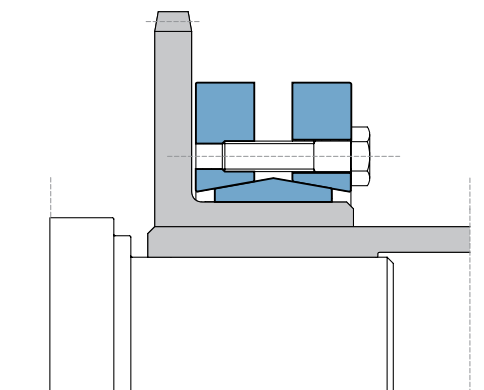

Contemporaneous locking of a sprocket and a hollow shaft.

Tollok™ Locking Assemblies

TLK 622/TLK 681-SHRINK DISCS

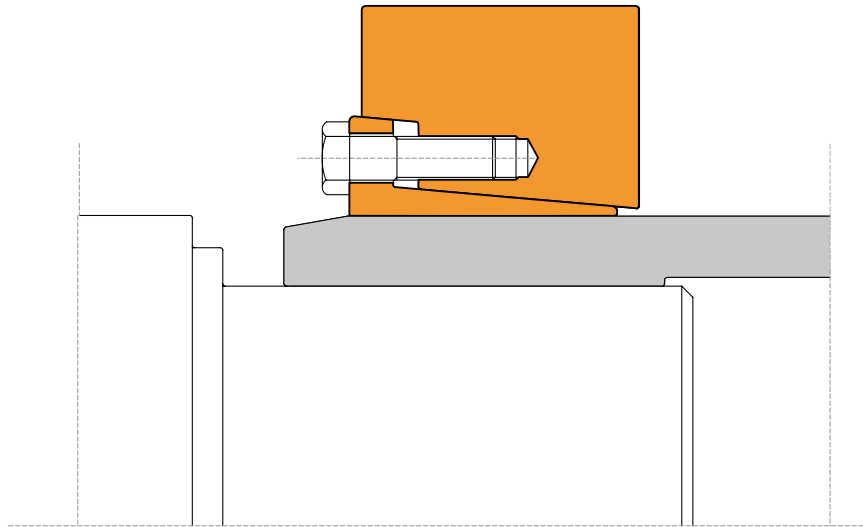

CHARACTERISTICS

- Very high torques
- No shaft-hub axial movement
- Limited installation time
- Quick dismantling

INSTALLATION

Carefully clean the hub and shaft contact surfaces. Slide the shrink disc outside the hollow shaft. Tighten gradually and regularly in continuous sequence all screws to reach the tightening torque M_s indicated in the table.

To reach the required tightening torque M_s , it is necessary to repeat the procedure more than once.

Do not use **molybdenum bisulphide** in the hub and shaft contact surfaces.

DISMANTLING

Loosen the clamping screws in a continuous and gradual sequence. Do not remove screws from threads. Normally with this operation the shrink disc is released.

In case of reuse, apply a solid lubricant (that can guarantee a friction coefficient equal to 0,04) in the screws and in the tapered surfaces.

TOLERANCES, SURFACE FINISH

A good surface finish by the machine tool is sufficient. Maximum allowable surface finish:

R_t max 16 μm (R_a 3 μm - R_z 13 μm)

Maximum permissible tolerances:

d = f7 for shaft

Dw diameter tolerances

dw: Up to 150 mm H7/h6
From 155 mm H7/g6

AXIAL MOVEMENT

During screws tightening the hub has no axial movement with respect to the shaft.

Tollok™ Locking Assemblies

TLK 622/TLK 681-SHRINK DISCS

TLK 622 - TLK 681 DIMENSIONS

Type	Shaft diameter	TLK 622			TLK 681			Dimensions					Tightening screws DIN931	Weight
		Torque	Axial force	Tightening torque	Torque	Axial force	Tightening torque	D	I	L	d1	e		
d mm	dw mm	M _t Nm	F _{ax} KN	M _s Nm	M _t Nm	F _{ax} KN	M _s Nm	D mm	I mm	L mm	d1 mm	e mm	Type	Kg
12	9	20	5											
	10	40	8	12				38	10	11	24	1	M6	0,1
	11	30	6											
14	12	50	9	12				38	10	11	26	1	M6	0,1
	13	70	10											
16	14	90	13	12				41	13,5	15	28	1,5	M6	0,1
	15	80	11											
18	16	110	14	12				44	13,5	15	30	1,5	M6	0,1
	17	150	18											
20	18	180	20	12				47	13,5	15	32	1,5	M6	0,1
	19	160	17											
24	20	210	20	12				50	16	18	36	2	M6	0,2
	22	280	25											
	24	270	23											
30	25	320	25	12				60	18	20	44	2	M6	0,3
	26	360	28											
	27	440	32											
36	30	610	41	30				72	20	22	52	2	M8	0,5
	33	820	50											
	34	690	41											
44	35	770	44	30				80	22	24	61	2	M8	0,6
	37	920	50											
	38	1110	58		1500	78								
50	40	1290	65	30	1700	85	35	90	23,5	26	68	2,5	M8	0,8
	42	1510	71		1900	93								
	42	1230	59		1600	78								
55	45	1530	68	30	2000	88	35	100	26	29	72	3	M8	1,1
	48	1860	78		2400	99								
	48	1670	70		2200	91								
62	50	1890	76	30	2400	98	35	110	26	29	80	3	M8	1,3
	52	2120	81		2700	104								
	50	1870	75		2400	94								
68	55	2450	89	30	3000	111	35	115	26	29	86	3	M8	1,3
	60	3120	104		3800	127								
	55	2330	85		3700	136								
75	60	3020	101	59	4700	157	70	138	27	31	100	4	M10	2,3
	65	3810	117		5800	178								
	60	3190	106		4200	142								
80	65	4060	123	59	5200	161	70	141	27	31	104	4	M10	2,3
	70	4910	140		6300	181								
	65	5400	166		5900	181								
90	70	6500	187	59	7100	203	70	155	34	38	114	4	M10	3,2
	75	7800	208		8500	226								
	70	6000	171		7400	213								
100	75	7200	192	59	8900	237	70	170	39	43	124	4	M10	4,3
	80	8500	213		10400	261								
	80	10000	249		12600	314								
110	85	11700	275	100	14600	344	121	185	43,5	49	138	5,5	M12	5,8
	90	13600	302		16900	375								
	85	11900	280		13600	320								
120	90	13800	307	100	15700	349	121	197	46,5	53	147	6,5	M12	6,9
	95	15900	334		18000	378								
	90	14400	319		16400	365								
125	95	16500	347	100	18800	395	121	215	46,5	53	152	6,5	M12	8,7
	100	18700	375		21300	426								
	95	18100	382		20300	427								
135	100	20600	412	160	23000	459	195	230	49,5	58	165	8,5	M14	11
	110	26000	473		28900	525								
	100	19600	392		23000	459								
140	105	22100	421	160	25800	492	195	230	49,5	58	170	8,5	M14	10
	115	27600	481		32100	558								
	110	26500	482		31100	565								
155	115	29500	514	160	34500	601	195	263	53,5	62	184	8,5	M14	15
	125	36100	578		42000	672								
	120	37300	622		44000	734								
165	125	41200	659	250	48500	776	300	290	58	68	198	10	M16	22
	135	49600	734		58100	860								
	130	45000	692		54000	834								
175	135	49000	730	250	59000	876	300	300	58	68	208	10	M16	23
	145	58000	805		70000	962								

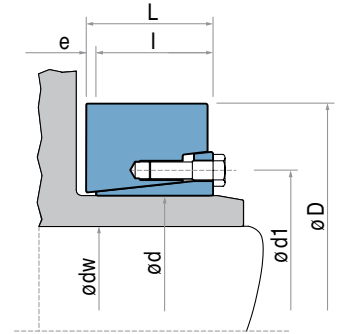

To be continued...

Tollok™ Locking Assemblies

TLK 622/TLK 681-SHRINK DISCS

TLK 622 - TLK 681 DIMENSIONS

Type	Shaft diameter	TLK 622			TLK 681			Dimensions					Tightening screws DIN931	Weight
		Torque	Axial force	Tightening torque	Torque	Axial force	Tightening torque	D	I	L	d1	e		
d mm	dw mm	M _t Nm	F _{ax} kN	M _s Nm	M _t Nm	F _{ax} kN	M _s Nm	D mm	I mm	L mm	d1 mm	e mm	Type	Kg
185	140	64000	916		81000	1157								
	145	70000	961	250	88000	1210	300	320	75	85	222	10	M16	33
	155	82000	1053		102000	1319								
200	150	81000	1073		96000	1279								
	155	87000	1120	250	103000	1333	300	340	75	85	238	10	M16	36
	165	100000	1216		119000	1442								
220	160	103000	1283		129000	1615								
	170	119000	1395	490	149000	1749	570	370	91	103	268	12	M20	53
	180	136000	1509		169000	1883								
240	170	122000	1439		151000	1773								
	180	140000	1555	490	172000	1909	570	405	94	107	288	13	M20	66
	200	179000	1790		218000	2183								
260	190	163000	1715		212000	2231								
	200	184000	1842	490	238000	2385	570	430	105	119	312	14	M20	82
	220	231000	2099		297000	2696								
280	210	215000	2051		279000	2661								
	220	240000	2186	490	311000	2825	570	460	116	132	334	16	M20	103
	240	295000	2458		379000	3156								
300	220	270000	2456		332000	3018								
	230	300000	2605	840	367000	3193	980	485	124	140	360	16	M24	120
	250	363000	2906		443000	3545								
320	240	301000	2511		404000	3370								
	250	332000	2655	840	444000	3549	980	520	124	140	380	16	M24	138
	270	398000	2945		528000	3911								
340	250	390000	3118		488000	3905								
	260	427000	3283	840	533000	4101	980	570	137	155	402	18	M24	189
	280	506000	3617		630000	4498								
350	270	493000	3649		616000	4563								
	280	535000	3825	840	669000	4778	980	580	142	162	414	20	M24	202
	290	580000	4001		725000	5000								

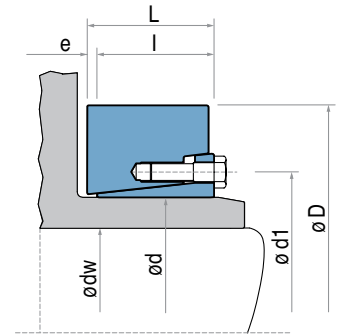

For larger diameter please contact us.

Tollok™ Locking Assemblies

CALCULATION OF MINIMUM HUB DIAMETER DM

By installing TOLLOK locking assemblies the surface pressure P_n , existing between the clamping outer ring and related hub bore, generate a stress. To calculate the minimum hub diameter **DM** the formula normally used for thick hollow cylinder is valid. Depending from

hub shape and length with respect to the dimension **L1** of locking assemblies, the real stresses change.

Factor C must be considered in function of application type.

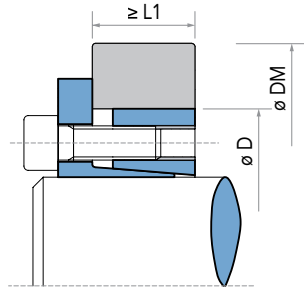

C=1

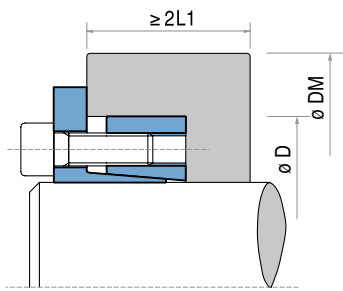
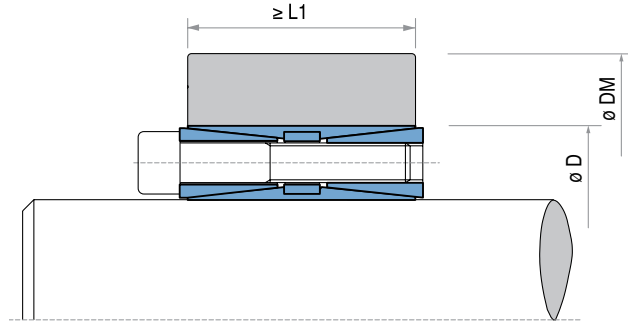

C=0,8

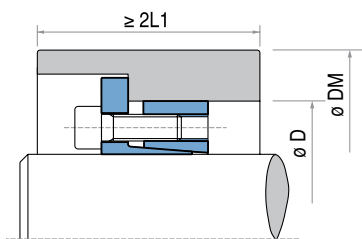
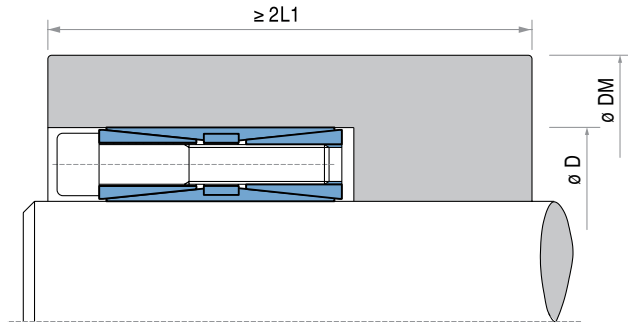

C=0,6

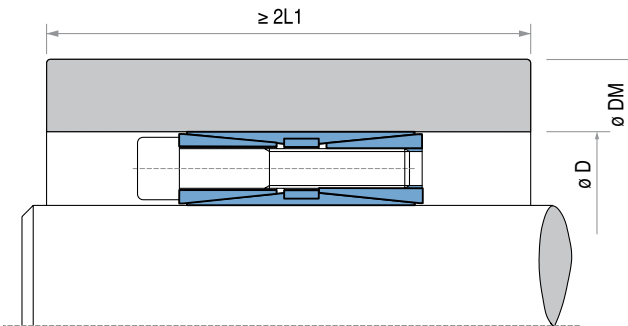

For minimum hub diameter DM calculation following formula must be applied:

$$DM \geq D \cdot K \quad \sqrt{\frac{\sigma_{02} + (C \cdot P_n)}{\sigma_{02} - (C \cdot P_n)}}$$

where **K** is equal to: **K** =

To simplify the calculation our technical department has prepared the table on page 31.

EXAMPLE:

Locking Assembly type TOLLOK TLK 131 \varnothing 60x90.

Hub pressure $P_n = 83 \text{ N/mm}^2$ (see table page 11).

Hub material GGG40 (yielding limit $\sigma_{02} = 250 \text{ N/mm}^2$).

Hub length and shape equivalent C = 1.

$$DM \geq 90 \cdot 1,42 \geq 127,8 \text{ mm}$$

Tollok™ Locking Assemblies

CALCULATION OF MINIMUM HUB DIAMETER DM

TABLE OF COEFFICIENT K

Pressure generated on the hub		σ_{02} Yield point N/mm ²										
		150	180	200	220	250	270	300	350	400	450	600
p N/mm ²	Application Type C	GG20	GG25 GS38	GG30 GTS35	GS45 ST37-2	GGG40 GS52	ST50-2 C35	GGG50 GS60 ST60-2	GGG60 GS62 ST70-2	GGG70 GS70 C60		
		60	C = 0,6	1,28	1,25	1,20	1,18	1,15	1,14	1,12	1,10	1,09
C = 0,8	1,39		1,30	1,24	1,23	1,22	1,20	1,18	1,15	1,12	1,11	1,08
C = 1	1,52		1,42	1,36	1,32	1,28	1,25	1,22	1,18	1,16	1,14	1,10
65	C = 0,6	1,30	1,25	1,22	1,20	1,18	1,15	1,13	1,11	1,10	1,09	1,07
	C = 0,8	1,44	1,35	1,30	1,28	1,24	1,22	1,20	1,16	1,14	1,12	1,09
	C = 1	1,60	1,45	1,40	1,35	1,30	1,28	1,24	1,20	1,18	1,16	1,12
70	C = 0,6	1,34	1,26	1,24	1,22	1,18	1,16	1,15	1,12	1,11	1,10	1,07
	C = 0,8	1,48	1,38	1,34	1,30	1,25	1,23	1,20	1,18	1,15	1,13	1,10
	C = 1	1,65	1,50	1,45	1,40	1,34	1,30	1,26	1,22	1,20	1,17	1,13
75	C = 0,6	1,30	1,28	1,25	1,23	1,20	1,18	1,16	1,14	1,12	1,11	1,08
	C = 0,8	1,52	1,42	1,36	1,32	1,28	1,25	1,22	1,18	1,16	1,14	1,11
	C = 1	1,74	1,55	1,48	1,42	1,36	1,33	1,30	1,25	1,20	1,18	1,13
80	C = 0,6	1,39	1,31	1,28	1,25	1,21	1,20	1,18	1,15	1,13	1,11	1,08
	C = 0,8	1,58	1,45	1,39	1,35	1,30	1,27	1,24	1,20	1,18	1,15	1,11
	C = 1	1,81	1,61	1,53	1,46	1,39	1,36	1,31	1,26	1,22	1,20	1,14
85	C = 0,6	1,42	1,34	1,30	1,27	1,23	1,21	1,19	1,16	1,14	1,12	1,09
	C = 0,8	1,63	1,49	1,42	1,38	1,32	1,29	1,26	1,22	1,19	1,16	1,12
	C = 1	1,90	1,67	1,57	1,50	1,42	1,39	1,34	1,28	1,24	1,21	1,15
90	C = 0,6	1,46	1,36	1,32	1,28	1,25	1,22	1,20	1,17	1,15	1,13	1,09
	C = 0,8	1,69	1,53	1,46	1,40	1,34	1,31	1,28	1,23	1,20	1,18	1,13
	C = 1	2,00	1,73	1,62	1,54	1,46	1,41	1,36	1,30	1,26	1,22	1,16
95	C = 0,6	1,49	1,39	1,34	1,30	1,26	1,24	1,21	1,18	1,15	1,14	1,10
	C = 0,8	1,75	1,57	1,49	1,43	1,37	1,34	1,30	1,25	1,21	1,19	1,14
	C = 1	2,11	1,80	1,68	1,59	1,49	1,44	1,39	1,32	1,27	1,24	1,17
100	C = 0,6	1,53	1,41	1,36	1,32	1,28	1,25	1,22	1,19	1,16	1,14	1,11
	C = 0,8	1,81	1,61	1,53	1,46	1,39	1,36	1,31	1,26	1,22	1,20	1,14
	C = 1	2,24	1,87	1,73	1,63	1,53	1,48	1,41	1,34	1,29	1,25	1,18
105	C = 0,6	1,56	1,44	1,39	1,34	1,29	1,27	1,24	1,20	1,17	1,15	1,11
	C = 0,8	1,88	1,66	1,56	1,50	1,42	1,38	1,33	1,28	1,24	1,21	1,15
	C = 1	2,38	1,95	1,79	1,68	1,56	1,51	1,44	1,36	1,31	1,27	1,19
110	C = 0,6	1,60	1,47	1,41	1,36	1,31	1,28	1,25	1,21	1,18	1,16	1,12
	C = 0,8	1,96	1,71	1,60	1,53	1,44	1,41	1,35	1,29	1,25	1,22	1,16
	C = 1	2,55	2,04	1,86	1,73	1,60	1,54	1,47	1,38	1,33	1,28	1,20
115	C = 0,6	1,64	1,50	1,43	1,36	1,33	1,30	1,26	1,22	1,19	1,17	1,12
	C = 0,8	2,04	1,76	1,64	1,56	1,47	1,43	1,37	1,31	1,26	1,23	1,17
	C = 1	2,75	2,13	1,93	1,79	1,64	1,58	1,50	1,41	1,34	1,30	1,21
120	C = 0,6	1,69	1,53	1,46	1,40	1,34	1,31	1,28	1,23	1,20	1,18	1,13
	C = 0,8	2,13	1,81	1,69	1,60	1,50	1,45	1,39	1,33	1,28	1,24	1,18
	C = 1	3,00	2,24	2,00	1,84	1,69	1,61	1,53	1,43	1,36	1,31	1,22
125	C = 0,6	1,73	1,56	1,48	1,43	1,36	1,33	1,29	1,24	1,21	1,18	1,13
	C = 0,8	2,24	1,87	1,73	1,63	1,53	1,48	1,41	1,34	1,29	1,25	1,18
	C = 1	3,32	2,35	2,08	1,91	1,73	1,65	1,56	1,45	1,38	1,33	1,24
130	C = 0,6	1,78	1,59	1,51	1,45	1,38	1,35	1,30	1,25	1,22	1,19	1,14
	C = 0,8	2,35	1,93	1,78	1,67	1,56	1,50	1,44	1,36	1,30	1,27	1,19
	C = 1	3,74	2,49	2,17	1,97	1,78	1,69	1,59	1,48	1,40	1,35	1,25
135	C = 0,6	1,83	1,62	1,54	1,47	1,40	1,36	1,32	1,27	1,23	1,20	1,15
	C = 0,8	2,48	2,00	1,83	1,71	1,59	1,53	1,46	1,38	1,32	1,28	1,20
	C = 1	4,36	2,65	2,27	2,04	1,83	1,73	1,62	1,50	1,42	1,36	1,26
140	C = 0,6	1,88	1,66	1,56	1,50	1,42	1,38	1,33	1,28	1,24	1,21	1,15
	C = 0,8	2,63	2,07	1,88	1,75	1,62	1,55	1,48	1,39	1,33	1,29	1,21
	C = 1	5,39	2,83	2,38	2,12	1,88	1,78	1,66	1,53	1,44	1,38	1,27
145	C = 0,6	1,94	1,69	1,59	1,52	1,44	1,40	1,35	1,29	1,25	1,22	1,16
	C = 0,8	2,80	2,15	1,94	1,80	1,65	1,58	1,50	1,41	1,35	1,30	1,22
	C = 1	7,68	3,05	2,50	2,21	1,94	1,82	1,69	1,55	1,46	1,40	1,28
150	C = 0,6	2,00	1,73	1,62	1,54	1,46	1,41	1,36	1,30	1,26	1,23	1,16
	C = 0,8	3,00	2,24	2,00	1,84	1,69	1,61	1,53	1,43	1,36	1,31	1,23
	C = 1	-	3,32	2,65	2,30	2,00	1,87	1,73	1,58	1,48	1,41	1,29
155	C = 0,6	2,06	1,77	1,65	1,57	1,48	1,43	1,38	1,31	1,27	1,24	1,17
	C = 0,8	3,25	2,33	2,06	1,89	1,72	1,65	1,55	1,45	1,38	1,33	1,23
	C = 1	-	3,66	2,80	2,40	2,06	1,92	1,77	1,61	1,51	1,43	1,30
160	C = 0,6	2,13	1,81	1,69	1,60	1,50	1,45	1,39	1,33	1,28	1,24	1,18
	C = 0,8	3,55	2,43	2,13	1,94	1,76	1,67	1,58	1,47	1,39	1,34	1,24
	C = 1	-	4,12	3,00	2,52	2,13	1,98	1,81	1,64	1,53	1,45	1,31
165	C = 0,6	2,21	1,86	1,72	1,62	1,52	1,47	1,41	1,34	1,29	1,25	1,18
	C = 0,8	3,96	2,55	2,21	2,00	1,80	1,71	1,60	1,49	1,41	1,35	1,25
	C = 1	-	4,80	3,23	2,65	2,21	2,04	1,86	1,67	1,55	1,47	1,33



TOLLOK™

Regal Rexnord

Customer Service: 800-626-2120

Technical Service: 800-626-2093

CustomerService.PTSolutions@regalrexnord.com

regalrexnord.com

The proper selection and application of products and components, including assuring that the product is safe for its intended use, are the responsibility of the customer. To view our Application Considerations, please visit <https://www.regalrexnord.com/Application-Considerations>.

To view our Standard Terms and Conditions of Sale, please visit <https://www.regalrexnord.com/Terms-and-Conditions-of-Sale> (which may redirect to other website locations based on product family).

"Regal Rexnord" is not indicative of legal entity. Refer to product purchase documentation for the applicable legal entity.

Regal Rexnord and Tollok are trademarks of Regal Rexnord Corporation or one of its affiliated companies.

© 2021, 2026 Regal Rexnord Corporation, All Rights Reserved. MCC-PT2-001-TO-EN-A4 01/26

 **RegalRexnord™**