



# Falk™ Quadrive™ Shaft-Mounted Drives

IMPERIAL



---

# Falk™ Quadrive™ Shaft-Mounted Drives

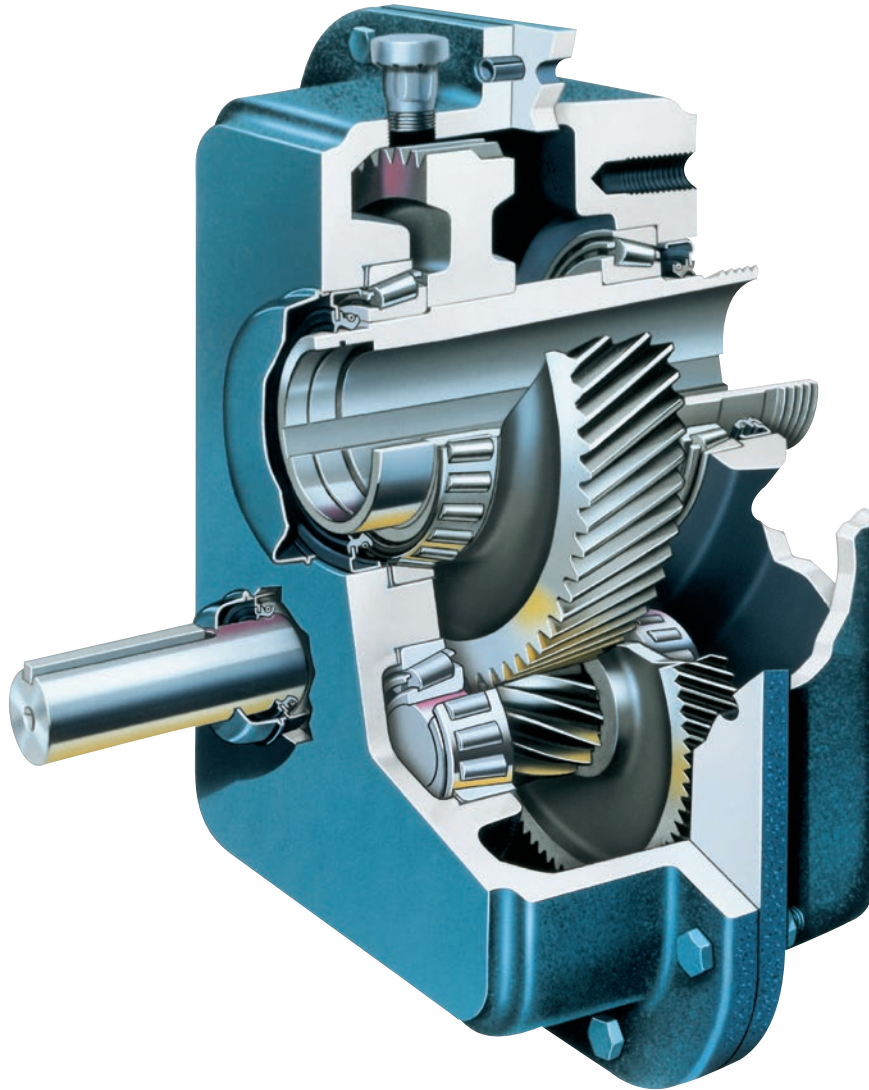

---

To learn more about the Falk Quadrive Shaft-Mounted Drives,  
go to [regalrexnord.com](http://regalrexnord.com), where you'll find:  
Product information • Brochures • Catalogs • Manuals  
Contact us at [regalrexnord.com/contact](http://regalrexnord.com/contact)

---



---

## Table Of Contents

DESCRIPTION	PAGE
<b>GENERAL INFORMATION</b>	
Falk™ Quadrive™ Basic Information . . . . .	4
Conditions Affecting Selection . . . . .	5
How to Select . . . . .	6
Drive Nomenclature . . . . .	7
Load Classifications . . . . .	8
<b>DRIVE SELECTION</b>	
Class I . . . . .	9
Class II . . . . .	11
Class III . . . . .	13
Engineering Data . . . . .	15
<b>DIMENSIONS &amp; PART NUMBERS</b>	
Size 5107 Shaft-Mounted (JR) & Flange-Mounted (JF) Drive . . . . .	18
Size 5107 Screw Conveyor (JSC) Drive . . . . .	19
Size 5115 Shaft-Mounted (JR) & Flange-Mounted (JF) Drive . . . . .	20
Size 5115 Screw Conveyor (JSC) Drive . . . . .	21
Size 5203 Shaft-Mounted (JR) & Flange-Mounted (JF) Drive . . . . .	23
Size 5203 Screw Conveyor (JSC) Drive . . . . .	24
Size 5207 Shaft-Mounted (JR) & Flange-Mounted (JF) Drive . . . . .	26
Size 5207 Screw Conveyor (JSC) Drive . . . . .	27
Size 5215 Shaft-Mounted (JR) & Flange-Mounted (JF) Drive . . . . .	29
Size 5215 Screw Conveyor (JSC) Drive . . . . .	30
Size 5307 Shaft-Mounted (JR) & Flange-Mounted (JF) Drive . . . . .	32
Size 5307 Screw Conveyor (JSC) Drive . . . . .	33
Size 5315 Shaft-Mounted (JR) & Flange-Mounted (JF) Drive . . . . .	35
Size 5315 Screw Conveyor (JSC) Drive . . . . .	36
Size 5407 Shaft-Mounted (JR) Drive . . . . .	38
Size 5407 Flange-Mounted (JF) Drive . . . . .	39
Size 5407 Screw Conveyor (JSC) Drive . . . . .	40
Size 5407 Motor Mounts . . . . .	41
Size 5415 Shaft-Mounted (JR) Drive . . . . .	42
Size 5415 Flange-Mounted (JF) Drive . . . . .	43
Size 5507 Shaft-Mounted (JR) Drive . . . . .	44
Size 5507 Flange-Mounted (JF) Drive . . . . .	45
Size 5608 Shaft-Mounted (JR) Drive . . . . .	46
Size 5608 Flange-Mounted (JF) Drive . . . . .	47
Size 5608 Motor Mounts . . . . .	48
<b>OPTIONS &amp; ADDITIONAL INFORMATION</b>	
Screw Conveyor Options . . . . .	49
Nominal Sheave Ratios and V-Belts . . . . .	50
V-Belt Guards . . . . .	51
Reliability Package . . . . .	54
Electric Fan Options . . . . .	56
Motor Mount Shaft Centers & Motor Frame Sizes . . . . .	58
Accessories/Options . . . . .	59
Suggested Drive Arrangement When Falk Motor Mount Is Not Used . . . . .	60



**Factory Warranty** — We're so confident in the performance and reliability of our latest generation of Falk gear drives that we're backing this comprehensive offering with the best standard warranty in the business. Our full, three-year heavy-duty warranty provides shaft-to-shaft protection on all Falk components – including bearings and seals (warranty extends for three years from date of shipment). It's an industry first and one more powerful reason why Falk is your ultimate bottom-line value.

See Extended Warranty statement (100-003) on our website: [www.rexnord.com/terms](http://www.rexnord.com/terms)

### Safety Notes

**Falk Gear Drives** — The Falk and Regal Rexnord name on the gear drive is the purchaser's assurance that the drive was engineered, rated and manufactured to sound design practices.

When one prime mover drives two pieces of equipment, one of which is either a standard Falk geared drive or a customer standard geared drive, the division of power between each machine is the responsibility of the customer. The power supplied to the geared drive must be equal to or less than the power for which the drive was selected using the appropriate service factor for the application. The customer must also assume the responsibility of isolating the geared drive from any vibratory or transient load induced by the driven equipment.

Install and operate Falk products in conformance with applicable local and national safety codes and per Regal Rexnord™ owner's manual which is available upon request. Suitable guards for rotating members may be purchased from Regal Rexnord as optional accessories. Consult your local Regal Rexnord Account Executive for complete details.

**People Conveying Equipment** — Selection of Falk Gear Drives for applications whose primary purpose is the transportation of people is not approved. This includes such applications as freight or passenger elevators, escalators, man lifts, work lift platforms and ski tows and ski lifts.

If the primary purpose of the application is material conveyance and occasionally people are transported, the Regal Rexnord warranty may remain in effect, provided the design load conditions are not exceeded and certification to the appropriate safety codes and load conditions has been obtained by the system designer or end user from the appropriate enforcement authorities.

### Gear Drive Ratings

Shaft-Mounted, Flange-Mounted and Screw Conveyor Drives are rated to a specific application by the use of Load Classifications. Each application has its own conditions and operating requirements. These have been analyzed and cataloged into three load classifications . . . uniform, moderate shock and heavy shock. Load classifications, based on field experience, have been assigned to these applications for service of 3 to 10 hours per day, and for service over 10 hours per day, and also for the type of prime mover. Values for most applications are listed on page 8. Refer unlisted applications to Factory.

Load Classifications are based on the assumption that the system is free of dynamic vibrations, as explained in the warranty section. Refer applications subject to repetitive shocks and applications where exceedingly high-energy load must be absorbed, as when stalling, to Factory for special consideration.

**Operating Temperature** — Gear drives can encounter sump oil temperatures up to 200° F (93° C). Higher temperatures are possible in localized areas. Since the drive will feel hot to the human hand at temperatures over 120° F (49° C), a portable pyrometer should be used to measure temperatures. Some drives, as indicated in the selection tables, are furnished with fans to ensure satisfactory operating temperatures.

**Conditions Affecting Gear Drive Selection and Application** — The following conditions may affect the drive selection procedure, drive size and auxiliary equipment being furnished. Refer to page 4 for more information.

- Excessive overloads
- Reversing service
- Brake-equipped applications
- Oversized prime movers
- Multi-speed or variable speed applications
- Excessive ambient temperatures
- Excessive overhung loads or thrust loads
- Product modification
- Non-standard mounting positions
- Backstops

**Stored & Inactive Drives** — Each gear drive is spin-tested with a rust-preventive oil that will protect parts against rust for a period of four months in an outdoor shelter or twelve months in dry building after shipment from Regal Rexnord.

Periodically inspect stored or inactive drives and spray or add rust inhibitor every six months or more often, if necessary. Indoor dry storage is recommended.

Drives ordered for extended storage can be treated at the Factory with a special preservative and sealed to rustproof parts for periods longer than those cited above, if specified on the order.

Refer to the appropriate service manual for extended storage of gear drives which have been in service.

## Conditions Affecting Selection

### Non-Standard Application Procedures

The following conditions may affect the drive selection procedure, drive size and auxiliary equipment being furnished.

**Excessive Overloads** — The maximum momentary or starting load must not exceed 200% of rated load (100% overload). Gear drive selections allow the following minimum momentary overloads for electric motor applications:

Class I Selections: 100% overload, or 200% of nominal motor rating.

Class II Selections: 180% overload, or 280% of nominal motor rating.

Class III Selections: 300% overload, or 400% of nominal motor rating.

If the maximum starting or momentary load exceeds the above conditions, refer to Factory.

**Reversing Service** — Applications involving either more than 20 reversals per 10 hour period, or less than 20 reversals per 10 hour period with peak torques greater than 200% of normal load must be referred to Factory.

**Brake-Equipped Applications** — When a gear drive is equipped with a “working” brake that is used to decelerate the motion of the system and the brake is located between the prime mover and the gear drive, select the drive based on the brake rating or the highest equivalent power rating, whichever is greater. If the brake is used for holding only and is applied after the motion of the system has come to rest, the brake rating must be less than 200% of the catalog rating of the gear drive selected for the application. If the brake rating is greater than 200% of the gear drive catalog rating, refer the application to the Factory. Also refer to Factory all applications in which the brake is located on the output shaft of the gear drive.

**Oversize Prime Movers** — Published Service Factors do not cover applications that require oversize prime movers for high energy or peak loads. Refer such applications to the Factory for selection of suitable drives.

**Speed Variation** — When selecting gear drives for multi-speed or variable speed applications, determine the speed which develops the greatest torque and select the gear drives on this basis. If the speed is not listed in the selection table, use the next lower output speed.

Refer all variable and multi-speed applications to the Factory. They may require special consideration to provide adequate lubrication at the slowest speed, but without excessive heating or churning at the highest speed. It is essential that all orders indicate minimum and maximum speeds, as well as the speed duration cycles.

**Effects of Solar Energy** — If a drive operates in the sun at ambient temperatures over 100° F (38° C), then special measures must be taken to protect the drive from solar energy. This protection can consist of a canopy over the drive or reflective paint on the drive. If neither is possible, additional cooling may be required to prevent the sump temperature from exceeding the allowable maximum of 200° F (93° C).

**Overhung Loads and Thrust Loads** — The overhung load and thrust ratings published in this selection guide are based on a service factor of unity and a combination of the most unfavorable conditions of rotation, speed, direction of applied load and drive loading. If the calculated load exceeds the published value, or if an overhung load and thrust load are applied simultaneously to a shaft, refer complete application details to the Factory. For more information refer to tables and guidelines on pages 16 and 17.

**Product Modifications** — Regal Rexnord can supply special product modifications to suit your application needs. Contact your local Regal Rexnord Account Executive for housing modifications, special ratios, special shafts, special mounting conditions, accessory modifications and other special application requirements.

**Mounting Positions** — All drives must be mounted within the limits specified on the dimension pages unless specifically ordered otherwise. Unless Factory approved, other mounting positions may lower the oil to a level that will starve gears and bearings; overfilling a drive with oil may cause leakage through the air vent, foaming and churning and consequently, overheating. Either condition can result in damage to gears and bearings.

**Backstops** — Backstops provide positive prevention of reverse rotation or backrun without backlash on conveyors, elevator head shafts and similar applications. Designed as standard accessories, backstops can be furnished on horizontal drives. Do not use backstops on vertical drives.

DO NOT use the backstop as a substitute for a brake.

These backstops are designed to prevent reverse rotation five times or less in eight hours, with one minute or more in the overrunning direction between backstopping load applications. If backstopping operations are more frequent, or the time between operations is less than one minute, the backstop is classified as a working or indexing device and the application must be referred to the Factory for engineering review.

When ordering a drive equipped with a backstop, specify whether the Falk™ hollow shaft is to rotate clockwise or counterclockwise when facing the input side of the gear drive.

## How to Select

### 1. Information required.

- Driven machine
- Motor horsepower/rpm/frame size
- Hours/day operation
- Driven shaft diameter/rpm
- Mounting requirements/space limits

If you have an unusual application involving any of the following conditions, refer to page 5.

- Excessive overloads
- Reversing service
- Brake-equipped applications
- Oversized prime movers
- Multi-speed or variable speed applications
- Excessive ambient temperatures
- Excessive overhung loads or thrust loads
- Product modifications
- Non-standard mounting positions

### 2. Drive selection.

Determine load classification based on the application from Table 1, page 8. Refer to Class I, II or III Selection Tables on pages 9-14. Select basic gear drive size and ratio opposite desired horsepower and output speed (note the minimum high-speed shaft sheave pitch diameter). Determine drive Type JR (Shaft-Mounted Drive), JF (Flange-Mounted Drive) or JSC (Screw Conveyor Drive). Also check the overhung load and thrust load. Thermal capacities in selection tables are based on 80°F (27°C) ambient. If ambient temperature exceeds this value, refer to Factory.

The selection tables show the most economical drive ratio for a given speed.

### 3. Check dimensions.

Refer to drive size dimension pages and check TA taper bushing bore, mounting position, clearances, and motor mount and motor frame size details.

### 4. Sheave ratios.

Nominal sheave ratios are given in Table 10, on page 50. Select final V-belt to suit the motor mount center distance and compare the driven sheave pitch diameter to the minimum determined in the selection table.

### Example

#### 1. Application details:

Uniformly-loaded inclined belt conveyor.

20 Horsepower, 1750 rpm motor, 256 T frame.

10 Hours/day operation.

2-11/16" Diameter head shaft at 44 rpm.

Shaft-mounted drive/horizontal.

#### 2. The load classification from Table 1, on page 8, is Class I. From the Class I selection, Table 2, on page 9, opposite 20 hp and output range of 28-53 rpm, the drive size is 5215J\_25 with a minimum H.S. sheave pitch diameter of 4.4". Drive type is a "JR" shaft-mounted drive.

#### 3. Refer to pages 29 and 30 to check drive dimension data. A hollow shaft Bushing No. BU5215J-2.688, Part No. 0769143 is required to fit the drive to the 2-11/16" diameter headshaft. A 6-o'clock mounting position is required. The motor mount center distance range available is 24.8-37.2", with a 256T frame motor.

#### 4. From Table 10, on page 50, the nominal sheave ratio is 1.59 for a 25:1 ratio drive with a 1750 rpm motor, at 44 rpm output. Select the V-belt drive to suit the available center distance range (short, medium or long). Be sure to allow for belt take up. Also, verify that the driven sheave pitch diameter is larger than the minimum specified.

### Order:

Basic Drive 5215JR25 PN 0794385

Bushing BU5215J-2.688 PN 0769143

Torque Arm TA52157J PN 0785267

Motor Mount MM5215J-2 PN 0786261

Backstop BS5215J05/09/14/25 PN 0785610

Clockwise Rotation

V-Belt Guard

# Drive Nomenclature

## Sizes 5107 thru 5315

JR Shaft-Mounted Drive

1. Basic Drive/Ratio (PN)
2. Bushing Size/Bore (PN)
3. Torque Arm (PN)

JF Flange-Mounted Drive

1. Basic Drive/Ratio (PN)
- Bushing Size/Bore (PN) — Optional  
(See Manual 377-142)

JSC Screw Conveyor Drive

1. Basic Drive/Ratio (PN)
  2. Seal Housing (PN)
- Seal Options (PN)
3. Driveshaft Dia. (PN)
- Thrust Plate Kit Included

## Sizes 5407 thru 5415

JR Shaft-Mounted Drive

1. Drive/Ratio (PN)
2. Bushing Size/Bore (PN)
3. Torque Arm (PN)

JF Flange-Mounted Drive

1. Drive/Ratio (PN)
- Flange Included
- Bushing Size/Bore (PN) — Optional  
(See Manual 377-144)

JSC Screw Conveyor Drive (5407 only)

1. Drive/Ratio (PN)
- Seal Housing Included
2. Driveshaft Dia. (PN)
- Thrust Plate Kit Included

## Sizes 5507 thru 5608

JR Shaft-Mounted Drive

1. Drive/Ratio (PN)
- Torque Arm Included
2. Bushing Size/Bore (PN)

## Accessories

- Motor Mount — Description/Motor Frame Size (PN)
- Backstop — Description/L.S. Rotation Viewing Input Side (PN) (Not available on vertical drives.)
- Shaft Cooling Fan — Specify on Order/Factory Installed (5215-5608J only)
- Electric Fan — Description (PN)/Specify Fan Mounting Position (5407-5608J) If Factory Installed
- Trough End — Description (PN)
- Thrust Plate Kit — Description (PN)
- TA Removal Tool — Description (PN)
- V-Belt Guard — Description (PN)

Contact Factory for special design options.

## Drive Nomenclature

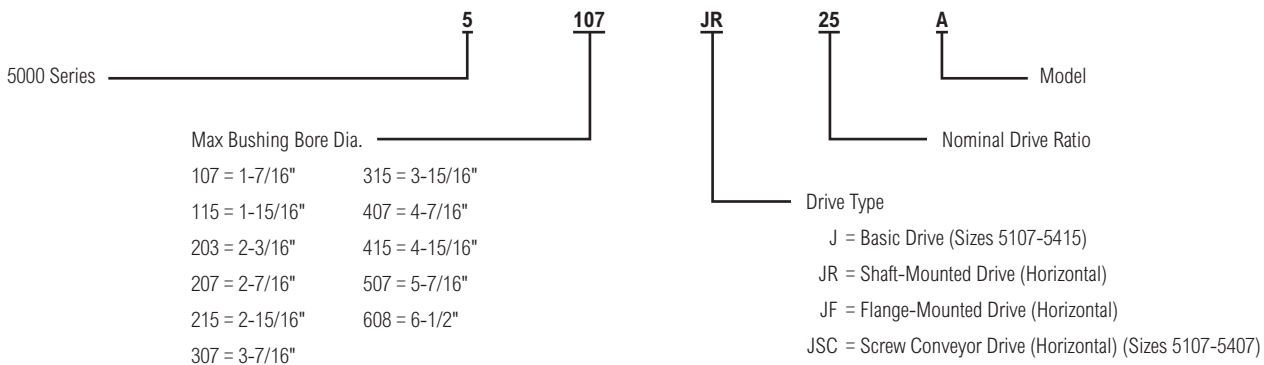

# Load Classifications <sup>①</sup>

## Electric Motor Driven Applications

Recommendations are minimum and normal conditions are assumed.

Table 1

Application	Service		Application	Service		Application	Service		Application	Service	
	3 to 10 Hour	Over 10 Hour		3 to 10 Hour	Over 10 Hour		3 to 10 Hour	Over 10 Hour		3 to 10 Hour	Over 10 Hour
<b>AGITATORS</b>			Belt	I	II	<b>LINE SHAFTS</b>			<b>PUMPS</b>		
Paper Mill (Mixers)	II	II	Flight	II	II	Uniform Load	I	II	Proportioning	Refer to	Factory
Pure Liquids	I	II	Oven	I	II	Heavy Load	II	II	Reciprocating, open		
Semi-Liquids, Variable Density	II	II	Live Roll (Package)	I	II	<b>LIVE ROLL CONVEYORS</b>			Discharge	I	II
<b>APRON CONVEYORS</b>			Screw	I	II	Uniformly-Loaded, Package	I	II	Double Acting		
Uniformly-Loaded	I	II	Table — See Metal Mills			Heavy-Duty	Refer to	Factory	Multi-Cylinder	II	III
Heavy-Duty	II	III	<b>CONVEYORS — Heavy-Duty — NOT UNIFORMLY FED <sup>②</sup></b>			<b>MACHINE TOOLS</b>			Single Cylinder	Refer to	Factory
<b>ASSEMBLY CONVEYORS</b>			Apron	II	III	Auxiliary Drives	I	II	Rotary (Gear Type)	I	II
Uniformly-Loaded	I	II	Assembly	II	II	Main Drives — Uniform Load	II	II	Constant Density		
Heavy-Duty	II	II	Belt	II	II	Main Drives — Heavy Load	III	III	Variable Density	II	II
<b>BELT CONVEYORS</b>			Bucket or Pan	II	II	<b>METAL MILLS</b>			<b>RECIPROCATING</b>		
Uniformly-Loaded	I	II	Flight	II	II	Table Conveyors,			Conveyors	III	III
Heavy-Duty	II	II	Live Roll	Refer to	Factory	Non Reversing	II	III	<b>RUBBER INDUSTRY</b>		
<b>BREWING &amp; DISTILLING</b>			Oven	II	II	Reversing	Refer to	Factory	<b>TIRE BUILDING MACHINES</b>	II	II
Bottling Machinery	I	II	Reciprocating	III	III	Wire Drawing & Flattening			Tire & Tube Press Openers	I	I
Brew Kettles, Continuous	—	II	Screw	II	II	Machines	III		<b>SCREENS</b>		
Can Filling Machines	I	II	Table — See Metal Mills	—	—	<b>MILLS</b>			Air Washing	I	II
Cookers, Continuous	—	II	<b>CRANES &amp; HOISTS <sup>②</sup></b>			(See Metal Mills)			Rotary, Stone or Gravel	II	II
Mash Tubs, Continuous	—	II	Bridge and Trolley Drive	II	II	Pebble	II	III	Traveling Water Intake	I	II
Scale Hoppers, Frequent Starts	II	II	<b>CUTTER HEAD DRIVES</b>	Refer to	Factory	<b>MIXERS — See Agitators</b>			Shaker	II	III
<b>BUCKET</b>			<b>DISTILLING — See Brewing</b>			Concrete, Continuous	II	III	<b>SCREW CONVEYORS</b>		
Conveyors, Heavy-Duty	II	II	<b>DRYERS &amp; COOLERS, ROTARY</b>	II	III	Concrete, Intermittent	II	—	Uniformly-Loaded	I	II
Elevators, Uniform Load	I	II	<b>ELEVATORS</b>			Constant Density	I	II	Heavy-Duty	II	II
Elevators, Heavy-Duty	II	III	Bucket — Uniform Load	I	II	Variable Density	II	II	<b>SKI TOWS &amp; LIFTS <sup>②</sup></b>	Not	Approved
<b>CAN FILLING MACHINES</b>			Bucket — Heavy Load	II	III	Liquid	I	II	<b>SKIP HOISTS <sup>②</sup></b>	II	—
<b>CAR</b>			Escalators <sup>②</sup>	Not	Approved	Paper Mill (Agitators)	II	II	<b>STOKERS</b>	—	II
Dumpers	III	—	Freight <sup>②</sup>	Not	Approved	Semi-Liquid	II	II	<b>TEXTILE INDUSTRY</b>		
Pullers	Refer to	Factory	Man lifts, Passenger <sup>②</sup>	Not	Approved	<b>OVEN CONVEYORS</b>			Batchers	II	II
<b>CLARIFIERS</b>			<b>FLIGHT CONVEYORS</b>			Uniformly-Loaded	I	II	Calenders	II	II
<b>CLASSIFIERS</b>			Uniformly-Loaded	II	II	Heavy-Duty	II	II	Card Machines	III	III
<b>CLAY WORKING MACHINERY</b>			Heavy-Duty	II	II	<b>PAN CONVEYORS</b>			Dry Cans	II	II
Brick Presses	III	III	<b>FOOD INDUSTRY</b>			Heavy-Duty	II	II	Dyeing Machinery	II	II
Briquette Machines	III	III	Beet Slicers	II	II	<b>PAPER MILLS</b>			Looms	Refer to	Factory
Extruders & Mixers	II	III	Can Filling Machines	I	II	Agitators (Mixers)	II	II	Mangles, Nappers & Soapers	II	II
<b>CONVEYORS — UNIFORMLY LOADED OR FED <sup>②</sup></b>			Cereal Cookers	I	II	Bleachers	I	II	Spinners	II	III
Apron and Assembly	I	II	Dough Mixers	II	II	Calenders	—	III	Tenter Frames	II	II
			Meat Grinders	II	II	Cylinders	—	II	<b>TUMBLING BARRELS</b>	III	III
			<b>LAUNDRY</b>			Felt Stretchers	—	II	<b>WINDLASS</b>	II	III
			Washers, reversing	Refer to	Factory	Winders	—	II			
			Tumblers	II	III	<b>PEBBLE MILLS</b>	II	III			

① **Load Classifications for Engine-Driven Applications** — Multi-Cylinder Engines: Use the next higher Service Class than the one given in Table 1 for the same application when motor-driven. (Example: A motor-driven, uniformly-loaded belt conveyor for 10-hour service is Class I; the same conveyor driven by a multi-cylinder engine would be Class II). For applications which require Class III when motor-driven, refer to Factory for recommendations on engine drives. Single Cylinder Engines: Refer to Factory.

② Selection of Falk™ products for applications whose primary purpose is the transportation of people is not approved. This includes such applications as freight or passenger elevators, escalators, man lifts, forklift platforms, ski tows, and ski lifts. If the primary purpose of the application is material conveyance and occasionally people are transported, the warranty may remain in effect, provided the design load conditions are not exceeded and certification to the appropriate safety codes and load conditions has been obtained by the system designer or end user from the appropriate enforcement authorities.

# Class I

## Quick Selections for <sup>®</sup> Shaft (JR) and Flange (JF) Mounted Drives — Sizes 5107 thru 5608, Screw Conveyor (JSC) Drives — Sizes 5107 thru 5407 (SF = 1.0)

Table 2

Motor HP	Output RPM	Selection	Min Sheave PD (in) <sup>②</sup>	Cooling Method	Motor HP	Output RPM	Selection	Min Sheave PD (in) <sup>②</sup>	Cooling Method	Motor HP	Output RPM	Selection	Min Sheave PD (in) <sup>②</sup>	Cooling Method
1/4	4-25	5107J_25	2.1	—	1-1/2	4-6	5207J_25	3.6	—	7-1/2	4-5	5407J_25	2.2	—
		5107J_25	2.1	—		7-10	5203J_25	2.6	—		6	5315J_25	2.2	—
	26-68	5107J_14	1.4	—		11-18	5115J_25	2.6	—		7-10	5307J_25	3.7	—
		5107J_09	2.2	—		19-25	5107J_25	2.1	—		11-20	5215J_25	4.4	—
	69-97	5107J_14	1.4	—		26-68	5107J_25	2.1	—		21-32	5207J_25	3.6	—
		5107J_09	2.2	—			5107J_14	1.4	—		32-51	5203J_25	2.6	—
		5107J_05	7.8	—			5107J_09	2.2	—		5203J_14	2.5	—	
	98-124	5107J_14	1.4	—		69-97	5107J_14	1.4	—		52-72	5115J_25	2.6	—
		5107J_09	2.2	—			5107J_09	2.2	—			5115J_14	1.7	—
		5107J_05	7.8	—			5107J_05	7.8	—		73-97	5115J_14	1.7	—
125-188	5107J_09	2.2	—	98-124	5107J_14	1.4	—	98-124	5107J_14	1.4	—			
	5107J_05	7.8	—		5107J_09	2.2	—		5107J_09	2.2	—			
1/3	4-25	5107J_25	2.1	—	125-188	5107J_05	7.8	—	125-188	5107J_09	2.2	—		
		5107J_25	2.1	—		5107J_05	7.8	—		5107J_05	7.8	—		
	26-68	5107J_14	1.4	—	189-350	5107J_05	7.1	—	189-350	5107J_05	7.1	—		
		5107J_09	2.2	—		4	5215J_25	4.4		—	4-5	5415J_25	3.3	—
	69-97	5107J_14	1.4	—	4	5-8	5207J_25	3.6	—	6-7	5407J_25	2.2	—	
		5107J_09	2.2	—		9-13	5203J_25	2.6	—	8	5315J_25	2.2	—	
		5107J_05	7.8	—		14-25	5115J_25	2.6	—	9-13	5307J_25	3.7	—	
	98-124	5107J_14	1.4	—	26-37	5107J_25	2.1	—	14-27	5215J_25	4.4	—		
		5107J_09	2.2	—		5107J_14	1.4	—		5207J_25	3.6	—		
		5107J_05	7.8	—		5107J_25	2.2	—		5207J_14	4.1	—		
125-188	5107J_09	2.2	—	38-69	5107J_14	2.1	—	28-42	5203J_25	2.6	—			
	5107J_05	7.8	—		5107J_09	1.4	—		5203J_14	3.1 <sup>Ⓞ</sup>	—			
1/2	4-7	5115J_25	2.6	—	70-121	5107J_14	2.2	—	70-128	5115J_14	2.2	—		
		5107J_25	2.1	—		5107J_09	7.8	—		5107J_09	2.2	—		
	26-68	5107J_14	1.4	—	122-185	5107J_05	1.4	—	129-188	5107J_05	7.8	—		
		5107J_09	2.2	—		5107J_09	2.2	—		5107J_05	7.1	—		
	69-97	5107J_14	1.4	—	186-350	5107J_05	7.1	—	189-350	5107J_05	7.1	—		
		5107J_09	2.2	—		4	5307J_25	14.7		—	4-5	5507J_25	2.6	—
		5107J_05	7.8	—		5-8	5215J_25	4.4		—	6-7	5415J_25	3.3	—
	98-124	5107J_14	1.4	—	9-12	5207J_25	3.6	—	8-11	5407J_25	2.2	—		
		5107J_09	2.2	—		13-20	5203J_25	2.6		—	12	5315J_25	3.7	—
		5107J_05	7.8	—		21-25	5115J_25	2.1		—	13-20	5307J_25	3.7	—
125-188	5107J_09	2.2	—	26-38	5115J_25	2.1	—	21-25	5215J_25	4.4	—			
	5107J_05	7.8	—		5115J_14	1.7	—		5215J_14	3.8	—			
3/4	4-5	5203J_25	2.6	—	39-68	5107J_25	2.1	—	26-40	5207J_25	3.6	—		
		5115J_25	2.6	—		5107J_14	1.4	—		5207J_14	4.1	—		
	10-25	5107J_25	2.1	—	69-97	5107J_14	1.4	—	41-66	5203J_25	2.6	—		
		5107J_14	1.4	—		5107J_09	2.2	—		5203J_14	3.1 <sup>Ⓞ</sup>	—		
	26-68	5107J_25	2.1	—	98-124	5107J_14	1.4	—	67-105	5203J_14	3.1 <sup>Ⓞ</sup>	—		
		5107J_14	1.4	—		5107J_09	2.2	—		106-111	5115J_14	2.0	—	
		5107J_09	2.2	—		5107J_05	7.8	—		5115J_14	2.2	—		
	69-97	5107J_14	1.4	—	125-188	5107J_14	1.4	—	112-128	5115J_09	2.7	—		
		5107J_09	2.2	—		5107J_09	2.2	—		5115J_05	6.4 <sup>Ⓞ</sup>	—		
		5107J_05	7.8	—		5107J_05	7.8	—		5115J_05	7.8	—		
98-124	5107J_14	1.4	—	189-350	5107J_09	2.2	—	129-225	5115J_05	7.8	—			
	5107J_09	2.2	—		5107J_05	7.8	—		226-350	5107J_05	7.1	—		
	5107J_05	7.8	—		5107J_05	7.8	—		4-5	5608J_25	3.6	—		
1	125-188	5107J_09	2.2	—	4-6	5307J_25	3.7	—	6-7	5507J_25	2.6	—		
		5107J_05	7.8	—		7-13	5215J_25	4.4		—	8-11	5415J_25	3.3	—
	189-350	5107J_05	7.1	—	14-21	5207J_25	3.6	—	12	5407J_25	2.2	—		
		4	5207J_25	3.6		—	21-33	5203J_25		2.6	—	16	5315J_25	2.2
	5-6	5203J_25	2.6	—	34-61	5115J_25	2.1	—	17-27	5307J_25	3.7	—		
		5115J_25	2.6	—		5115J_14	1.7	—		5215J_25	4.4	—		
	7-10	5107J_25	2.1	—	62-66	5107J_25	2.1	—	28-53	5215J_14	4.8 <sup>Ⓞ</sup>	—		
		5107J_14	1.4	—		5107J_14	1.4	—		5207J_25	3.6	—		
	26-68	5107J_25	2.1	—	67-97	5107J_25	2.1	—	54-70	5207J_14	6.6	—		
		5107J_14	1.4	—		5115J_14	1.7	—		5207J_09	9.2 <sup>Ⓞ</sup>	—		
5107J_09		2.2	—	5107J_14		1.4	—	5207J_09		8.7	—			
69-97	5107J_14	1.4	—	98-124	5107J_09	2.2	—	71-87	5207J_14	3.7	—			
	5107J_09	2.2	—		5107J_09	2.2	—		88-104	5203J_14	3.7	—		
	5107J_05	7.8	—		5107J_05	7.8	—		5203J_14	3.7	—			
98-124	5107J_14	1.4	—	125-188	5107J_14	1.4	—	105-122	5203J_09	6.3	—			
	5107J_09	2.2	—		5107J_09	2.2	—		5207J_05	8.7	—			
	5107J_05	7.8	—		5107J_05	7.8	—		5203J_09	6.4	—			
125-188	5107J_14	1.4	—	189-350	5107J_09	2.2	—	123-152	5207J_05	8.7	—			
	5107J_09	2.2	—		5107J_05	7.8	—		5115J_09	3.4	—			
	5107J_05	7.8	—		5107J_05	7.8	—		5207J_05	8.5	—			
189-350	5107J_09	2.2	—	4	5207J_25	3.6	—	191-199	5203J_05	6.2	—			
	5107J_05	7.8	—		5	5207J_25	3.6		—	200-350	5115J_05	6.1	—	
189-350	5107J_09	2.2	—	5	5-6	5203J_25	2.6	—						
	5107J_05	7.8	—		7-10	5115J_25	2.6	—						
189-350	5107J_09	2.2	—	10-25	5107J_25	2.1	—							
	5107J_05	7.8	—		26-68	5107J_25	2.1	—						

**Class I — Continued**

**Quick Selections for <sup>Ⓛ</sup> Shaft (JR) and Flange (JF) Mounted Drives — Sizes 5107 thru 5608, Screw Conveyor (JSC) Drives — Sizes 5107 thru 5407 (SF = 1.0)**

**Table 2 – Continued**

Motor HP	Output RPM	Selection	Min Sheave PD (in) <sup>Ⓜ</sup>	Cooling Method	Motor HP	Output RPM	Selection	Min Sheave PD (in) <sup>Ⓜ</sup>	Cooling Method	Motor HP	Output RPM	Selection	Min Sheave PD (in) <sup>Ⓜ</sup>	Cooling Method		
25	5-6	5608J_25	3.6	—	50 Cont.	60-70	5307J_25	4.9	—	100	75 Cont.	196-315	5307J_05	14.1 <sup>Ⓝ</sup>	—	
	7-9	5507J_25	2.6	—			5307J_14	8.1	—		316-350	5215J_05	8.0	—		
	10-12	5415J_25	3.3	—			5307J_09	14.1	—		18-25	5608J_25	3.6	—		
	13-19	5407J_25	2.2	—		71-113	5215J_14	6.3	—		26-29	5507J_25	2.7	—		
	20-37	5307J_25	3.9	—			5215J_09	9.1	—		30-40	5507J_25	2.9	Shaft Fan		
	30	38-67	5307J_14	6.7		—	114-128	5215J_14	7.3 <sup>Ⓝ</sup>		Shaft Fan	41-52	5507J_14	6.0	—	
			5215J_25	4.4		—		5215J_09	8.7		—		41-52	5415J_25	3.3	Electric Fan
		68-118	5215J_14	5.9 <sup>Ⓝ</sup>		—	129-140	5215J_09	8.2		—	53-70	5415J_14	6.7	Electric Fan	
			5207J_14	7.6 <sup>Ⓝ</sup>		—		5307J_05	14.4		—		53-70	5407J_25	3.1	Electric Fan
		40	119-122	5207J_09		9.5	—	141-165	5215J_09		8.0 <sup>Ⓝ</sup>	Shaft Fan	71-79	5407J_14	4.7	Electric Fan
				5203J_14		3.7	—		5307J_05		14.4	—		71-79	5407J_14	4.9
			123-134	5207J_09		9.5	—	166-189	5215J_09		7.6	Shaft Fan	80-95	5315J_14	12.5 <sup>Ⓝ</sup>	Electric Fan
				5203J_09		9.3	—		5215J_05		9.8	—		80-95	5307J_14	8.2
			135-187	5207J_05		8.7	—	190-340	5215J_05		9.3	—	96-128	5315J_09	15.3	Electric Fan
				5207J_05		8.4	—		5207J_05		8.1	—		96-128	5407J_05	12.4
	50		188-267	5207J_05		8.4	—	341-350	5207J_05		8.1	—	129-139	5315J_09	14.8	Electric Fan
				268-286		5203J_05	6.2		—		11-15	5608J_25		3.6	—	129-139
			287-350	5115J_05		5.8	—	24-31	5415J_25		3.3	—	140-179	5315J_09	14.6	Electric Fan
6-7				5608J_25	3.6	—	5415J_14		6.8	—	140-179	5315J_05		15.3	—	
60		8-11	5507J_25	2.6	—	32-46	5407J_25	2.5	—	180-195	5307J_09	10.5	Electric Fan			
			12-15	5415J_25	3.3		—	5407J_14	3.7		—	180-195	5315J_05	15.0	—	
		16-23	5407J_25	2.2	—	47-48	5315J_25	3.2	Electric Fan	196-232	5315J_05	14.7 <sup>Ⓝ</sup>	—			
			24-41	5307J_25	3.7		—	5315J_14	7.8		—	233-355	5307J_05	13.7	—	
		75	42-70	5307J_14	6.7	—	49-70	5307J_25	4.9	Electric Fan	22-32	5608J_25	6.0 <sup>Ⓝ</sup>	—		
				5215J_25	4.4	—		5307J_14	8.1	—		33-50	5507J_25	3.3 <sup>Ⓝ</sup>	Shaft Fan	
	71-85		5215J_14	6.2	—	71-77	5307J_14	8.1	—	51-66	5507J_14	6.1	—			
			5215J_09	7.5 <sup>Ⓝ</sup>	—		5315J_09	15.4	—		51-66	5415J_25	3.3	Electric Fan		
	100		86-121	5215J_14	9.1 <sup>Ⓝ</sup>	—	78-83	5307J_14	8.1	—	67-70	5415J_14	6.7	Shaft Fan		
				5207J_14	7.6	—		5307J_09	14.0	—		67-70	5407J_25	3.1	Electric Fan	
122-177			5207J_09	9.5	—	84-89	5307J_14	8.1	—	71-104	5407J_14	4.6	Electric Fan			
			5215J_05	9.8	—		5215J_09	14.0	—		71-104	5407J_14	5.9 <sup>Ⓝ</sup>	Electric Fan		
178-195			5207J_14	6.2	—	90-123	5215J_14	6.9	Shaft Fan	105-131	5415J_14	6.6	Electric Fan			
			5207J_05	8.5	—		5215J_09	9.1	—		105-131	5407J_05	12.4	—		
150		196-343	5207J_05	8.4	—	124-128	5215J_14	7.3	Shaft Fan	132-144	5315J_09	14.8	Electric Fan			
			344-350	5203J_05	6.2		—	5215J_09	9.1		Shaft Fan	132-144	5407J_05	12.4	—	
		200	7-10	5608J_25	3.6	—	129-195	5215J_09	8.2	Shaft Fan	145-194	5407J_05	12.4	—		
				11-16	5507J_25	2.6		—	5307J_05	14.4		—	195-314	5315J_05	14.7 <sup>Ⓝ</sup>	—
	17-21		5415J_25	3.3	—	195-217	5307J_05	14.1	—	315-340	5315J_05	12.0	Shaft Fan			
			22-25	5407J_25	2.2		—	218-350	5215J_05		8.9	—	341-362	5307J_05	11.6	Shaft Fan
	250		26-31	5407J_25	2.2	—	14-19	5608J_25	4.1	—	26-32	5608J_25	6.0 <sup>Ⓝ</sup>	Shaft Fan		
				5407J_14	3.3	—		20-26	5507J_25	2.6		—	26-32	5608J_14	5.7	—
			32-38	5307J_25	3.7	—	27-30	5507J_25	2.7	—	33-38	5608J_25	6.8	Shaft Fan		
				5307J_14	6.7	—		5507J_14	6.1	—		33-38	5608J_14	5.7	—	
300			39-55	5307J_25	4.9	—	31-39	5415J_25	3.3	Shaft Fan	39-61	5507J_25	3.7 <sup>Ⓝ</sup>	Electric Fan		
				5307J_14	8.1 <sup>Ⓝ</sup>	—		5415J_14	6.7	—		39-61	5507J_14	6.2	Electric Fan	
		56-70	5215J_25	4.4	—	40-58	5407J_25	2.8	Shaft Fan	62-72	5507J_25	4.0	Electric Fan			
			5215J_14	6.2	—		5407J_14	4.3	Shaft Fan		62-72	5415J_14	6.7	Electric Fan		
		400	71-128	5215J_09	7.5	—	59-61	5315J_25	3.6	Shaft Fan	73-90	5415J_14	6.7	Electric Fan		
				5215J_14	7.3 <sup>Ⓝ</sup>	—		5315J_14	10.0	Shaft Fan		73-90	5415J_14	6.6	Electric Fan	
	129-178		5215J_09	9.1 <sup>Ⓝ</sup>	—	62-64	5315J_25	3.6	Shaft Fan	91-122	5415J_14	6.6	Electric Fan			
			5207J_09	9.3	—		5315J_14	10.0	Shaft Fan		91-122	5415J_05	12.6	—		
	179-185		5207J_09	9.2	Shaft Fan	65-70	5315J_09	15.5	—	123-216	5407J_05	12.4	—			
			5215J_05	9.8	—		5307J_25	4.9	Electric Fan		217-259	5407J_05	12.4	Shaft Fan		
500	186-246		5215J_05	9.8	—	71-96	5307J_14	8.1	Electric Fan	260-362	5315J_05	13.3 <sup>Ⓝ</sup>	Electric Fan			
			247-350	5207J_05	8.4		—	5315J_09	15.7		—	35-43	5608J_25	7.5	Electric Fan	
	9-12		5608J_25	3.6	—	97-108	5307J_14	8.1	Electric Fan	44-51	5608J_25	8.7	Electric Fan			
			13-20	5507J_25	2.6		—	5315J_09	15.5		Electric Fan	44-51	5608J_14	6.7	Electric Fan	
	21-26	5415J_25	3.3	—	109-121	5307J_14	8.2	Electric Fan	52-87	5507J_14	7.5	Electric Fan				
		5407J_25	2.2	—		5307J_09	13.1	Electric Fan		52-87	5507J_14	7.5	Electric Fan			
	600	27-38	5407J_14	3.4	—	122-128	5215J_14	7.3	P&C	88-105	5507J_14	8.3	Electric Fan			
			5315J_25	3.0	—		5215J_09	8.3	P&C		88-105	5507J_05	11.7	—		
		39	5315J_14	7.1	—	129-151	5315J_05	15.5	—	106-138	5507J_05	11.5	—			
			5315J_09	11.6	—		5215J_09	8.2	P&C		106-138	5415J_05	12.5	Electric Fan		
40-59		5307J_25	4.9	—	152-195	5315J_05	15.2	—	139-161	5415J_05	12.5	Electric Fan				
		5307J_14	8.1 <sup>Ⓝ</sup>	—		5215J_09	7.6	P&C		162-184	5415J_05	12.5	Shaft Fan			

Ⓛ **Horizontal Drives** – Refer to Engineering 377-114 for maximum output speeds. **Vertical Drives** – Make selection from Table 2, Table 3 or Table 4 and then refer to Engineering 377-114 to determine drive speed limits with and without cooling.  
 Ⓜ Values are for V-belt drives and load applied one shaft diameter from seal cage or fan if so equipped. For minimum sheave diameters for other axial locations, refer to load location factor table 6 on page 16. Multiply values by 0.66 when using timing belt or chain drives.  
 Ⓝ Minimum sheave PD is maximum for speed range. Consult factory for lower values.

## Class II

### Quick Selections for <sup>®</sup> Shaft (JR) and Flange (JF) Mounted Drives — Sizes 5107 thru 5608, Screw Conveyor (JSC) Drives — Sizes 5107 thru 5407 (SF = 1.4)

Table 3

Motor HP	Output RPM	Selection	Min Sheave PD (in) <sup>②</sup>	Cooling Method	Motor HP	Output RPM	Selection	Min Sheave PD (in) <sup>②</sup>	Cooling Method	Motor HP	Output RPM	Selection	Min Sheave PD (in) <sup>②</sup>	Cooling Method		
1/4	4	5115J_25	2.6	—	1-1/2	125-188	5107J_09	2.2	—	7-1/2	4	5507J_25	2.6	—		
	5-25	5107J_25	2.1	—		Cont.	5107J_05	7.8	—		5	5415J_25	3.3	—		
	26-68	5107J_25	2.1	—		189-350	5107J_05	7.1	—		6-9	5407J_25	2.2	—		
		5107J_14	1.4	—		4-5	5215J_25	4.3	—		9-14	5307J_25	3.7	—		
	69-97	5107J_09	2.2	—		6-10	5207J_25	3.6	—		15-28	5215J_25	4.4	—		
		5107J_14	1.4	—		11-14	5203J_25	2.6	—		29-45	5207J_25	3.6	—		
	98-124	5107J_09	2.2	—		15-27	5115J_25	2.6	—		46-60	5203J_25	2.6	—		
		5107J_05	7.8	—		28-68	5107J_25	2.1	—		5203J_14	2.4	—			
	125-188	5107J_14	1.4	—		5107J_14	1.4	—	61-69		5203J_14	3.1	—			
		5107J_09	2.2	—		5107J_09	2.2	—	5203J_09		5.5	—				
	189-350	5107J_05	7.8	—		69-97	5107J_14	1.4	—		70-71	5203J_14	3.2	—		
		5107J_05	7.1	—		5107J_05	7.8	—	72		5115J_25	2.6	—			
	1/3	4-5	5115J_25	2.6		—	2	98-124	5107J_14		1.4	—	73-80	5115J_14	1.7	—
		6-25	5107J_25	2.1		—		5107J_09	2.2		—	80-128	5115J_14	2.2	—	
		26-68	5107J_25	2.1		—		5107J_05	7.8		—	128-136	5115J_09	2.8	—	
			5107J_14	1.4		—		125-188	5107J_09		2.2	—	5107J_09	2.2	—	
		69-97	5107J_09	2.2		—		189-350	5107J_05		7.1	—	137-159	5107J_05	7.8	—
			5107J_14	1.4		—		4-7	5215J_25		4.4	—	189-350	5107J_05	7.1	—
98-124		5107J_09	2.2	—	8-11	5207J_25		3.6	—	4-5	5507J_25	2.6	—			
		5107J_05	7.8	—	12-19	5203J_25		2.6	—	6-7	5415J_25	3.3	—			
125-188		5107J_09	2.2	—	20-26	5115J_25		2.6	—	8-10	5407J_25	2.2	—			
		5107J_05	7.8	—	27-37	5115J_25		2.6	—	11	5315J_25	2.2	—			
189-350		5107J_05	7.1	—	5115J_14	1.8		—	12-19	5307J_25	3.7	—				
		5107J_05	7.1	—	5107J_25	2.2		—	20-26	5215J_25	4.4	—				
1/2		4	5203J_25	2.6	—	3		38-69	5107J_14	2.1	—	27-37	5215J_25	4.4	—	
		5-9	5115J_25	2.6	—			5107J_09	1.4	—	38-49	5207J_25	3.6	—		
		9-25	5107J_25	2.1	—			5107J_14	2.2	—	50-60	5207J_25	3.6	—		
		26-68	5107J_25	2.1	—			70-121	5107J_09	7.8	—	61-66	5203J_25	2.4	—	
			5107J_14	1.4	—			5107J_05	1.4	—	5203J_14	3.1	—			
		69-97	5107J_09	2.2	—			122-185	5107J_09	2.2	—	67-97	5203J_14	3.7	—	
	5107J_05		7.8	—	5107J_05		7.8	—	98-128	5115J_14	2.2	—				
	98-124	5107J_14	1.4	—	186-350		5107J_05	7.1	—	129-350	5115J_09	6.0	—			
		5107J_09	2.2	—	4-5		5307J_25	3.7	—	4-5	5608J_25	3.6	—			
	125-188	5107J_05	7.8	—	6-11		5215J_25	4.3	—	6-8	5507J_25	2.6	—			
		5107J_05	7.8	—	12-18		5207J_25	3.6	—	9-11	5415J_25	3.3	—			
	189-350	5107J_05	7.1	—	19-29		5203J_25	2.6	—	12-16	5407J_25	2.2	—			
		5107J_05	7.1	—	30-52		5115J_25	2.1	—	17-29	5307J_25	3.7	—			
	3/4	4	5207J_25	3.6	—		5	55-68	5107J_25	2.1	—	30-56	5215J_25	4.4	—	
		5-7	5203J_25	2.6	—			5107J_14	1.4	—	5215J_14	5.1 <sup>③</sup>	—			
		8-13	5115J_25	2.6	—			5107J_09	2.2	—	57-70	5207J_25	3.6	—		
		14-25	5107J_25	2.1	—			5107J_05	7.8	—	5207J_14	6.9	—			
		26-68	5107J_25	2.1	—			69-97	5107J_09	2.2	—	71-90	5207J_14	7.6	—	
5107J_14			1.4	—	5107J_14	1.4		—	91-111	5203J_14	3.7	—				
69-97		5107J_09	2.2	—	5107J_09	2.2		—	111-157	5203J_09	6.4	—				
		5107J_05	7.8	—	5107J_05	7.8		—	158-188	5115J_09	3.5	—				
98-124		5107J_14	1.4	—	125-188	5107J_09		2.2	—	189-211	5207J_05	8.4	—			
		5107J_09	2.2	—	5107J_05	7.8		—	211-346	5203J_05	6.2	—				
125-188		5107J_05	7.8	—	189-350	5107J_05		7.1	—	5-7	5608J_25	3.6	—			
		5107J_05	7.1	—	4-5	5407J_25		2.2	—	8-11	5507J_25	2.6	—			
1		4-6	5207J_25	3.6	—	15		6-9	5307J_25	3.7	—	12-14	5415J_25	3.3	—	
		7-9	5203J_25	2.6	—			10-18	5215J_25	4.4	—	15-21	5407J_25	2.2	—	
		10-17	5115J_25	2.6	—			19-30	5207J_25	3.6	—	22	5315J_25	2.2	—	
		18-25	5107J_25	2.1	—			31-37	5203J_25	2.6	—	23-39	5307J_25	4.0	—	
		26-68	5107J_25	2.1	—			5203J_14	2.1	—	40-81	5215J_25	4.4	—		
			5107J_14	1.4	—			38-48	5203J_25	2.6	—	5215J_14	4.8 <sup>③</sup>	—		
	69-97	5107J_09	2.2	—	49-72		5115J_25	2.6	—	82-121	5207J_14	7.5	—			
		5107J_14	1.4	—	5115J_14		1.7	—	5207J_09	9.2	—					
	98-124	5107J_14	1.4	—	73-92		5115J_14	1.8	—	121-161	5207J_09	9.2	—			
		5107J_09	2.2	—	5107J_09		2.5	—	162-195	5203J_09	6.3	—				
	1	5107J_09	2.2	—	5107J_14		1.4	—	5207J_05	8.3	—					
		5107J_05	7.8	—	93-124		5107J_09	2.2	—	196-313	5207J_05	8.5	—			
		5107J_14	1.4	—	5107J_05		7.8	—	314-346	5203J_05	6.2	—				
		5107J_14	1.4	—	125-188		5107J_09	2.2	—							
		5107J_09	2.2	—	5107J_05		7.8	—								
		5107J_05	7.8	—	189-350		5107J_05	7.1	—							

**Class II — Continued**

**Quick Selections for <sup>①</sup> Shaft (JR) and Flange (JF) Mounted Drives — Sizes 5107 thru 5608, Screw Conveyor (JSC) Drives — Sizes 5107 thru 5407 (SF = 1.4)**

**Table 3 – Continued**

Motor HP	Output RPM	Selection	Min Sheave PD (in) <sup>②</sup>	Cooling Method	Motor HP	Output RPM	Selection	Min Sheave PD (in) <sup>②</sup>	Cooling Method	Motor HP	Output RPM	Selection	Min Sheave PD (in) <sup>②</sup>	Cooling Method
25	7-8	5608J_25	3.6	—	50 Cont.	57-59	5307J_25	4.9	—	100	25-34	5608J_25	6.2	—
	9-14	5507J_25	2.6	—			5307J_14	8.1	—		35-44	5608J_25	7.6	—
	15-18	5415J_25	3.3	—			5315J_09	15.5	—		5507J_14	6.2	—	
	19-27	5407J_25	2.6	—		60-70	5307J_25	3.6	—		45-60	5608J_25	9.7	Shaft Fan
	28	5315J_25	2.6	—			5307J_14	10.0	—		5507J_25	3.6	Shaft Fan	
	29-48	5307J_25	4.6	—			5315J_09	15.5	—		5507J_14	6.2	—	
		5307J_14	6.9	—		71-104	5307J_14	8.1	—		61-69	5415J_25	3.3	Electric Fan
	49-70	5215J_25	4.4	—			5315J_09	15.5	—		5415J_14	6.7	Shaft Fan	
		5215J_14	6.2	—		105-112	5307J_14	8.1	—		70-74	5415J_14	6.7	Shaft Fan
	71-106	5215J_14	6.2	—			5215J_09	8.8	—		5415J_14	6.7	Shaft Fan	
5207J_14		7.6 <sup>③</sup>	—	113-128	5215J_14	7.3 <sup>③</sup>	—	75-80	5407J_14	5.8	Electric Fan			
5207J_09	9.5	—	5215J_09		8.7	—	81-102	5407J_14	5.8	Electric Fan				
122-185	5207J_09	9.5	—	129-139	5215J_09	8.2	—	103-128	5407J_14	6.8	Electric Fan			
186-204	5215J_05	9.8	—		5215J_09	8.0	Shaft Fan	5415J_14	6.6	Electric Fan				
205-349	5207J_05	8.4	—	140-154	5307J_05	14.4	—	129-155	5407J_05	12.4	—			
30	7-10	5608J_25	3.6		—	155-277	5307J_05	14.1	—	156-192	5407J_05	12.4	—	
	11-16	5507J_25	2.6	—	278-355	5215J_05	8.5	—	193-235	5315J_09	14.5	Electric Fan		
	17-21	5415J_25	3.3	—	15-21	5608J_25	4.7 <sup>③</sup>	—	236-266	5407J_05	12.4	—		
	22-25	5407J_25	2.2	—	22-26	5507J_25	2.6	—	267-316	5315J_05	12.8	—		
		5407J_25	2.2	—	27-33	5507J_25	2.8	—	317-362	5315J_05	11.9	—		
	26-31	5407J_14	3.3	—		5507J_14	6.1	—	32-40	5608J_25	7.1	Electric Fan		
	32-38	5307J_25	3.7	—	34-44	5415J_25	3.3	—	38-53	5608J_14	6.9	Shaft Fan		
		5307J_14	6.7	—		5415J_14	6.7	—	54-65	5608J_14	7.9	Shaft Fan		
	39-55	5307J_25	4.9	—	45-50	5407J_25	2.6	—	47-72	5507J_25	4.0	Electric Fan		
		5307J_14	8.1 <sup>③</sup>	—		5407J_14	3.9	—		5507J_14	6.9	Shaft Fan		
56-70	5215J_25	4.4	—	51-66	5407J_25	3.0	Shaft Fan	73-122	5415J_14	6.7	Electric Fan			
	5215J_14	6.2	—		5407J_14	4.5	—	123-152	5415J_05	12.5	—			
71-128	5215J_09	7.5	—	67-71	5315J_25	3.8	Shaft Fan	153-213	5415J_05	12.5	—			
	5215J_14	7.3 <sup>③</sup>	—		5315J_14	10.9	—	5407J_05	12.4	—				
40	129-178	5207J_09	9.3	—	72-74	5315J_14	11.3	—	214-351	5407J_05	12.4	Shaft Fan		
		5215J_05	9.8	—		5315J_09	15.5	—	352-362	5315J_05	11.4	Shaft Fan		
	179-185	5207J_09	9.2	—	75-97	5307J_14	8.1	—	37-46	5608J_25	7.9	Shaft Fan		
		5215J_05	9.8	—		98-128	5315J_09	15.4	—	47-63	5608J_14	7.6	Shaft Fan	
	186-246	5215J_05	9.8	—	129-138		5307J_14	8.2	Shaft Fan	54-72	5507J_25	4.0	—	
	247-350	5207J_05	8.4	—		5307J_09	12.7	—	54-72	5507J_14	6.9	Electric Fan		
	50	10-14	5608J_25	3.6	—	139-177	5315J_05	15.1	—	73-90	5507J_14	7.9	Electric Fan	
		15-22	5507J_25	2.6	—		5307J_09	12.4 <sup>③</sup>	Shaft Fan	86-122	5415J_14	6.6	Electric Fan	
		23-25	5415J_25	3.3	—	178-195	5315J_05	15.3	—	97-147	5507J_05	11.5	—	
		26-29	5415J_25	3.3	—		5307J_09	10.5	Electric Fan	148-197	5415J_05	12.5	—	
5415J_14			6.8	—	5307J_05	14.1	—	198-351	5407J_05	12.4	—			
30-43		5407J_25	2.4	—	196-362	5307J_05	14.1 <sup>③</sup>	—	50-54	5608J_25	8.9	Electric Fan		
		5407J_14	3.5	—		18-25	5608J_25	3.6	—	55-66	5608J_25	10.6	Electric Fan	
44-45		5315J_25	3.1	—	26-29	5507J_25	2.7	—	67-70	5608J_25	11.2	Electric Fan		
		5315J_14	7.4	—		30-40	5507J_25	2.9	—	71-73	5608J_14	8.6	Electric Fan	
46-70		5307J_25	4.9	—	5507J_14		6.0	—	74-84	5507J_14	7.6	Electric Fan		
	5307J_14	8.1	—	41-52	5415J_25	3.3	Shaft Fan	85-105	5507J_14	8.3	Electric Fan			
71-78	5307J_14	8.1	—		5415J_14	6.7	—	145-190	5507J_05	11.4	—			
	5307J_09	14.1	—	53-70	5407J_25	3.1	Shaft Fan	191-222	5507J_05	11.2	Electric Fan			
79-82	5215J_09	8.7	—		5407J_14	4.7	Shaft Fan	223-268	5415J_05	12.5	—			
83-99	5215J_14	6.3	—	71-79	5407J_14	4.9	Shaft Fan	269-298	5415J_05	12.5	Electric Fan			
	5215J_09	9.1	—		80-95	5315J_14	12.5 <sup>③</sup>	Electric Fan	299-351	5407J_05	12.3	Electric Fan		
50	100-128	5215J_14	7.3 <sup>③</sup>	—	96-128	5307J_14	8.2	Electric Fan	250	202-352	5507J_05	11.2	Electric Fan	
		5215J_09	9.1	—		5315J_09	15.3	Electric Fan						
	5307J_05	14.7	—	129-139	5407J_05	12.4	—							
	5215J_09	8.2	—		5315J_09	14.8	Electric Fan							
	129-154	5307J_05	14.4	—	140-179	5407J_05	12.3	—						
	155-196	5307J_05	14.4	—		5315J_09	14.6	Electric Fan						
	197-355	5215J_05	9.3	—	180-195	5315J_05	15.3	—						
	12-17	5608J_25	4.1	—		5307J_09	10.5	Electric Fan						
	18-27	5507J_25	2.6	—	196-232	5315J_05	15.0	—						
	28-36	5415J_25	3.3	—		5307J_05	13.7	—						
5415J_14		6.8	—											
37-56	5407J_25	2.7	—											
	5407J_14	4.2	—											

① **Horizontal Drives** – Refer to Engineering 377-114 for maximum output speeds. **Vertical Drives** – Make selection from Table 2, Table 3 or Table 4 and then refer to Engineering 377-114 to determine drive speed limits with and without cooling.  
 ② Values are for V-belt drives and load applied one shaft diameter from seal cage or fan if so equipped. For minimum sheave diameters for other axial locations, refer to load location factor table on page 16. Multiply values by 0.66 when using timing belt or chain drives.  
 ③ Minimum sheave PD is maximum for speed range. Consult factory for lower values.

### Class III

#### Quick Selections for <sup>Ⓢ</sup> Shaft (JR) and Flange (JF) Mounted Drives — Sizes 5107 thru 5608, Screw Conveyor (JSC) Drives — Sizes 5107 thru 5407 (SF = 2.0)

Table 4

Motor HP	Output RPM	Selection	Min Sheave PD (in) <sup>Ⓢ</sup>	Cooling Method	Motor HP	Output RPM	Selection	Min Sheave PD (in) <sup>Ⓢ</sup>	Cooling Method	Motor HP	Output RPM	Selection	Min Sheave PD (in) <sup>Ⓢ</sup>	Cooling Method		
1/4	4-6	5115J_25	2.6	—	1-1/2 Cont.	69-121	5107J_14	1.4	—	7-1/2 Cont.	126-187	5115J_09	3.5	—		
	7-24	5107J_25	2.1	—		5107J_09	2.2	—	188-218		5115J_05	6.4	—			
	25-68	5107J_25	2.1	—		5107J_05	7.8	—	219-350		5107J_05	7.1	—			
		5107J_14	1.4	—		5107J_05	7.8	—	4		5608J_25	3.7	—			
	69-121	5107J_14	1.4	—		186-350	5107J_05	7.1	—		5-7	5507J_25	2.6	—		
		5107J_09	2.2	—		4-5	5307J_25	3.7	—		8-10	5415J_25	3.3	—		
	122-185	5107J_05	7.8	—		6-11	5215J_25	4.4	—		11-15	5407J_25	2.2	—		
		5107J_09	2.2	—		12-16	5207J_25	3.6	—		16-27	5307J_25	3.7	—		
	1/3	186-350	5107J_05	7.1		—	17-29	5203J_25	2.6		—	10	28-54	5215J_25	4.4	—
		4-5	5203J_25	2.6		—	5115J_25	2.5	—		5215J_14		5.1 <sup>Ⓢ</sup>	—		
6-8		5115J_25	2.6	—	30-51	5115J_14	2.6	—	5207J_25	3.6	—					
9-24		5107J_25	2.1	—	5115J_09	1.8	—	5207J_14	6.9 <sup>Ⓢ</sup>	—						
25-68		5107J_25	2.1	—	5107J_25	2.2	—	5207J_09	9.2 <sup>Ⓢ</sup>	—						
		5107J_14	1.4	—	5107J_14	2.1	—	71-84	5207J_14	7.6 <sup>Ⓢ</sup>	—					
69-121		5107J_09	2.2	—	5107J_09	1.4	—	85-121	5207J_09	9.2	—					
		5107J_14	1.4	—	5107J_14	2.2	—	5203J_14	3.7	—						
122-185		5107J_09	2.2	—	70-121	5107J_09	7.8	—	5203J_09	6.3	—					
		5107J_05	7.8	—	5107J_05	1.4	—	5207J_05	8.8	—						
1/2	186-350	5107J_05	7.1	—	122-185	5107J_09	2.2	—	15	122-146	5203J_09	6.6	—			
	4	5207J_25	3.6	—	5107J_05	7.8	—	5207J_05		8.7	—					
	5-6	5203J_25	2.6	—	186-350	5107J_05	7.1	—		147-187	5115J_09	3.4	—			
	7-12	5115J_25	2.6	—	4	5407J_25	2.2	—		5115J_05	6.4	—				
	13-24	5107J_25	2.1	—	5-8	5307J_25	3.7	—		5115J_05	6.1	—				
	25-68	5107J_25	2.1	—	9-15	5215J_25	4.4	—		6-7	5608J_25	3.7	—			
		5107J_14	1.4	—	16-25	5207J_25	3.6	—		8-11	5507J_25	2.6	—			
	69-121	5107J_14	1.4	—	26-41	5203J_25	2.6	—		12-15	5415J_25	3.3	—			
		5107J_09	2.2	—	5203J_14	2.1	—	16-22		5407J_25	2.2	—				
	122-185	5107J_14	1.4	—	5115J_25	2.6	—	23-24		5315J_25	2.4	—				
5107J_05		7.8	—	5115J_14	1.8	—	25-40	5307J_25	4.0	—						
3/4	186-350	5107J_05	7.1	—	71-77	5115J_09	2.5	—	20	41-70	5307J_14	6.7	—			
	4-6	5207J_25	3.6	—	5115J_14	1.8	—	5215J_25		4.4	—					
	7-11	5203J_25	2.6	—	5115J_09	2.5	—	5215J_14		6.2 <sup>Ⓢ</sup>	—					
	12-18	5115J_25	2.6	—	5107J_05	7.8	—	5215J_09		8.7 <sup>Ⓢ</sup>	—					
	19-24	5107J_25	2.1	—	5107J_14	1.4	—	5215J_14		6.2	—					
	25-68	5107J_14	1.4	—	78-121	5107J_09	2.2	—		5215J_09	8.7 <sup>Ⓢ</sup>	—				
		5107J_09	2.2	—	5107J_05	7.8	—	5207J_14		7.6	—					
	69-121	5107J_09	2.2	—	122-185	5107J_09	2.2	—		5207J_09	9.5	—				
		5107J_05	7.8	—	5107J_05	7.8	—	5215J_05		9.8	—					
	122-185	5107J_09	2.2	—	186-350	5107J_05	7.1	—		127-191	5203J_09	6.6	—			
5107J_05		7.8	—	4-5	5415J_25	3.3	—	5207J_05	8.7	—						
1	186-350	5107J_05	7.1	—	6-7	5407J_25	2.2	—	20	192-256	5207J_05	8.4	—			
	4-5	5215J_25	4.4	—	8-13	5307J_25	3.7	—		257-350	5115J_05	5.9	—			
	6-8	5207J_25	3.6	—	14-27	5215J_25	4.4	—		7-9	5608J_25	3.7	—			
	9-13	5203J_25	2.6	—	28-41	5207J_25	3.6	—		10-15	5507J_25	2.6	—			
	14-24	5115J_25	2.6	—	5207J_14	4.4	—	16-20		5415J_25	3.3	—				
	25	5107J_25	2.1	—	5207J_09	6.3	—	21-25		5407J_25	2.2	—				
		5115J_14	1.8	—	5203J_25	2.6	—	5407J_25		2.2	—					
	26-68	5107J_25	2.1	—	42-71	5203J_14	3.2 <sup>Ⓢ</sup>	—		26-32	5407J_25	2.2	—			
		5107J_14	1.4	—	5203J_09	5.6 <sup>Ⓢ</sup>	—	5407J_14		3.3	—					
	69-121	5107J_09	2.2	—	72-127	5115J_14	2.2	—		33-38	5307J_25	4.0	—			
5107J_05		7.8	—	5115J_09	2.7	—	5307J_14	6.7	—							
122-185	5107J_09	2.2	—	5115J_05	6.8	—	5307J_25	4.9	—							
	5107J_05	7.8	—	5107J_09	2.2	—	5307J_14	8.1	—							
1-1/2	186-350	5107J_05	7.1	—	128-185	5107J_05	7.8	—	20	39-54	5307J_09	14.0	—			
	4	5307J_25	3.7	—	5107J_05	7.8	—	5215J_25		4.4	—					
	5-7	5215J_25	4.4	—	186-350	5107J_05	7.1	—		5215J_14	6.2 <sup>Ⓢ</sup>	—				
	8-12	5207J_25	3.6	—	4-5	5507J_25	2.6	—		5215J_09	7.8 <sup>Ⓢ</sup>	—				
	13-20	5203J_25	2.6	—	6-7	5415J_25	3.3	—		5215J_14	6.3	—				
	21-25	5115J_25	2.6	—	8-11	5407J_25	2.2	—		5215J_09	9.1 <sup>Ⓢ</sup>	—				
	26-38	5115J_14	1.8	—	12-15	5315J_25	2.2	—		5307J_05	14.7	—				
		5115J_09	2.4	—	16-20	5307J_25	3.7	—		5215J_14	6.3	—				
	39-68	5107J_25	2.1	—	21-25	5215J_25	4.4	—		5215J_09	9.1	—				
		5107J_14	1.4	—	26-45	5215J_25	4.4	—		5215J_05	9.8	—				
	5107J_09	2.2	—	5215J_14	4.2	—	5215J_14	7.3 <sup>Ⓢ</sup>	—							
				5207J_25	3.6	—	5207J_09	9.5	—							
				46-69	5207J_14	6.9 <sup>Ⓢ</sup>	—	5215J_05	9.8	—						
					5207J_09	9.2 <sup>Ⓢ</sup>	—	5207J_09	9.3	—						
				70-106	5203J_14	3.7	—	5215J_05	9.8	—						
					5203J_09	3.7	—	5215J_05	9.8	—						
					5207J_05	8.8	—	5207J_05	8.4	—						
				107-125	5115J_14	2.2	—									
					5115J_09	2.7	—									
					5115J_05	6.2	—									

**Class III — Continued**

**Quick Selections for <sup>®</sup> Shaft (JR) and Flange (JF) Mounted Drives — Sizes 5107 thru 5608, Screw Conveyor (JSC) Drives — Sizes 5107 thru 5407 (SF = 2.0)**

**Table 4 – Continued**

Motor HP	Output RPM	Selection	Min Sheave PD (in) <sup>②</sup>	Cooling Method	Motor HP	Output RPM	Selection	Min Sheave PD (in) <sup>②</sup>	Cooling Method	Motor HP	Output RPM	Selection	Min Sheave PD (in) <sup>②</sup>	Cooling Method	
25	9-12	5608J_25	3.7	—	40 Cont.	119-129	5215J_14	7.3	—	75 Cont.	85-116	5407J_14	6.3 <sup>③</sup>	Shaft Fan	
	13-19	5507J_25	2.6	—			5407J_05	12.5	—						
	20-25	5415J_25	3.3	—			5315J_14	11.6	Electric Fan						
	26-38	5407J_25	2.2	—		5215J_05	9.8	—	117-126		5315J_09	15.1	Electric Fan		
		5407J_14	3.3	—		5215J_05	8.5	—			5407J_05	12.4	—		
	39-41	5315J_25	3.0	—		17-26	5608J_25	5.9 <sup>③</sup>	—		127-177	5315J_09	14.8	Electric Fan	
		5315J_14	7.1	—		27-39	5507J_25	2.9	—			5407J_05	12.4	—	
		5315J_09	12.4	—		5507J_14	6.1	—	178-192		5315J_09	14.2	Electric Fan		
	42-73	5307J_25	4.9	—		40-51	5415J_25	3.3			—	5315J_05	15.1	—	
		5307J_14	8.1	—		5415J_14	6.7	—	193-292		5315J_05	14.6 <sup>③</sup>	—		
		5307J_09	14.0	—	52-70	5407J_25	3.1	—		5307J_05	12.8 <sup>③</sup>	—			
	74-131	5215J_14	7.3 <sup>③</sup>	—	5407J_14	4.9	—	71-77	5407J_14	4.9	—	35-41	5608J_25	7.1	—
		5215J_09	9.1 <sup>③</sup>	—	78-93	5315J_14	12.3		—	5608J_25	8.4 <sup>③</sup>		Shaft Fan		
		5307J_05	14.7	—	5315J_09	15.3	—	5608J_14	6.7	—	42-50	5507J_25	4.1	Shaft Fan	
		5215J_09	9.8	—	5407J_05	12.5	—	5507J_14	6.9	Shaft Fan					
	132-141	5207J_09	9.2	—	94-99	5307J_14	8.1	—	73-79	5507J_14	7.3	Shaft Fan			
		5215J_05	9.8	—		5315J_09	15.1	—		5507J_05	11.7	—			
	142-184	5207J_09	9.2	—	5407J_05	12.4	—	80-87	5415J_14	6.7	Electric Fan				
		5215J_05	9.8	—	5307J_14	8.1	—		5507J_05	11.7	—				
	185-263	5215J_05	9.8 <sup>③</sup>	—	50	100-110	5315J_09	15.2	—	88-104	5415J_14	6.6	Electric Fan		
264-350	5207J_05	8.4	—	5315J_05			15.8	—	5415J_05		12.6	—			
11-14	5608J_25	3.8	—	111-125		5307J_14	8.1	—	105-113	5407J_14	6.2	Electric Fan			
	15-25	5507J_25	2.6			—	5307J_09	13.1		—	5415J_05	12.5	—		
26-30	5415J_25	3.3	—	5315J_05		15.5	—	114-126	5407J_14	6.7	Electric Fan				
	5415J_14	6.8	—	5307J_09		12.8	—		5407J_05	12.4	—				
31-47	5407J_25	2.5	—	126-135		5315J_05	15.3	—	127-165	5407J_05	12.4	—			
	5407J_14	3.7	—			5215J_09	8.0	Shaft Fan		5315J_09	14.3	Electric Fan			
48-53	5307J_25	4.9	—	136-154		5315J_05	15.2	—	166-192	5407J_05	12.4	—			
	5307J_14	8.1	—			5315J_05	15.2	—		5407J_05	12.4	—			
	5315J_09	15.2	—	155-163	5315J_05	15.2	—	193-267	5407J_05	12.4	—				
54-73	5307J_14	8.1	—	164-287	5307J_05	14.1 <sup>③</sup>	—	268-350	5315J_05	12.8 <sup>③</sup>	—				
	5307J_09	14.0	—	288-350	5307J_05	12.8 <sup>③</sup>	—	43-53	5608J_25	8.9 <sup>③</sup>	Shaft Fan				
30	5307J_14	8.1	—	60	21-25	5608J_25	5.2	—	54-63	5608J_25	10.1 <sup>③</sup>	Shaft Fan			
	74-81	5307J_09	14.0		—	26-30	5608J_25	5.7		—	5608J_14	7.9 <sup>③</sup>	Shaft Fan		
	5315J_05	15.7	—		5608J_14	5.0	—	64-72	5507J_25	4.1	Electric Fan				
	5215J_14	7.3 <sup>③</sup>	—		5507J_25	3.1	—		5507J_14	6.9	Shaft Fan				
	82-129	5215J_09	9.1 <sup>③</sup>		—	5507J_14	6.0	—	73-100	5507J_14	8.3 <sup>③</sup>	Electric Fan			
		5307J_05	14.7		—	48-62	5415J_25	3.3		Shaft Fan	5507J_05	11.7	—		
	130-166	5215J_09	8.2		—	5415J_14	6.7	—	101-110	5415J_14	6.6	Electric Fan			
		5307J_05	14.4		—	63-70	5407J_25	3.1		Shaft Fan	5507J_05	11.4	—		
	167-170	5215J_09	7.6		Shaft Fan	5407J_14	4.6	—	111-129	5415J_14	6.6	Electric Fan			
		5307J_05	14.1		—	71-93	5407J_14	5.5		Shaft Fan	5415J_05	12.5	—		
171-185	5215J_09	7.6	Shaft Fan	5407J_05	12.5	—	129-143	5415J_05	12.5	—					
	5215J_05	9.8	—	94-129	5315J_14	11.6	Shaft Fan	144-266	5407J_05	12.4	—				
186-350	5215J_05	9.8	—	5315J_09	15.1	—	267-350	5407J_05	12.4	Shaft Fan					
40	14-19	5608J_25	4.1	—	75	130-143	5315J_09	14.8	Shaft Fan	52-63	5608J_25	10.1 <sup>③</sup>	Shaft Fan		
	20-26	5507J_25	2.6	—			5315J_05	15.3	—	5608J_25	11.2 <sup>③</sup>	Electric Fan			
	27-31	5507J_25	2.7	—		5307J_09	11.9 <sup>③</sup>	Shaft Fan	5608J_14	8.4	Electric Fan				
		5507J_14	6.1	—		5315J_05	15.2	—	73-76	5608J_14	8.6	Electric Fan			
	32-41	5415J_25	3.3	—		179-195	5307J_09	10.5	Electric Fan	77-87	5507J_14	7.8	Electric Fan		
		5415J_14	6.7	—		5315J_05	15.1	—	88-129	5507J_14	8.3	Electric Fan			
	42-61	5407J_25	2.8	—		196-213	5315J_05	14.7	—	5507J_05	11.6	—			
		5407J_14	4.3	—		214-350	5307J_05	13.8 <sup>③</sup>	—	130-133	5507J_05	11.4	—		
	62-70	5315J_25	3.7	—		26-31	5608J_25	5.7	—	134-173	5415J_05	12.5	—		
		5315J_14	10.5	—		5608J_25	6.8	—	174-350	5407J_05	12.4	Shaft Fan			
5315J_09		15.6	—	5608J_14	5.7	—	117-130	5507J_05	11.5	—					
71-80	5307J_14	8.1	—	39-60	5507J_25	3.7		Shaft Fan	181-234	5415J_05	12.5	Shaft Fan			
	5315J_09	15.5	—	5507J_14	6.2	—	235-350	5407J_05	12.4	Electric Fan					
81-108	5315J_05	15.7	—	61-69	5415J_25	3.3	Shaft Fan	146-228	5507J_05	11.4	Shaft Fan				
	5307J_14	8.1	—		5415J_14	6.7	—	229-300	5415J_05	12.4	Electric Fan				
	5307J_09	14.0	—	70-78	5415J_14	6.7	Shaft Fan		301-350	5407J_05	12.3	Electric Fan			
109-118	5315J_05	15.7	—	79-84	5415J_05	12.6	—								
	5215J_14	6.7	—		5407J_14	5.1	Shaft Fan								
	5215J_09	8.7	—	5415J_05	12.6	—									

① **Horizontal Drives** – Refer to Engineering 377-114 for maximum output speeds. **Vertical Drives** – Make selection from Table 2, Table 3 or Table 4 and then refer to Engineering 377-114 to determine drive speed limits with and without cooling.  
 ② Values are for V-belt drives and load applied one shaft diameter from seal cage or fan if so equipped. For minimum sheave diameters for other axial locations, refer to load location factor table on page 16. Multiply values by 0.66 when using timing belt or chain drives.  
 ③ Minimum sheave PD is maximum for speed range. Consult factory for lower values.

# Engineering Data

Motor Ratings and Dimensions are in accordance with NEMA standards

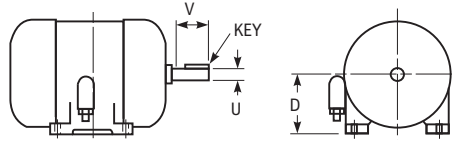

Table 5 — 1964 (Type T) NEMA Motor Standards ①

Motor Speed and Frame Size												Motor Shaft Dimensions (in)														
Motor HP	1800 RPM	1200 RPM	900 RPM	Motor HP	1800 RPM	1200 RPM	900 RPM	Motor HP	1800 RPM	1200 RPM	900 RPM	Motor Frame	D	U	V	Key (Sq)	Motor Frame	D	U	V	Key (Sq)	Motor Frame	D	U	V	Key (Sq)
1/2	56	56	143	7-1/2	213	254	256	50	326	365	404	56	3-1/2	5/8	2	3/16	215	5-1/4	1-3/8	3-1/8	5/16	326	8	2-1/8	5	1/2
3/4	56	143	145	10	215	256	284	60	364	404	405	143	3-1/2	7/8	2	3/16	254	6-1/4	1-5/8	3-3/4	3/8	364	9	2-3/8	5-5/8	5/8
1	143	145	182	15	254	284	286	75	365	405	—	145	3-1/2	7/8	2	3/16	256	6-1/4	1-5/8	3-3/4	3/8	365	9	2-3/8	5-5/8	5/8
1-1/2	145	182	184	20	256	286	324	100	404	—	—	182	4-1/2	1-1/8	2-1/2	1/4	284	7	1-7/8	3/8	1/2	404	10	2-7/8	7	3/4
2	145	184	213	25	284	324	326	125	405	—	—	184	4-1/2	1-1/8	2-1/2	1/4	286	7	1-7/8	3/8	1/2	405	10	2-7/8	7	3/4
3	182	213	215	30	286	326	364	150	444	—	—	213	5-1/4	1-3/8	3-1/8	5/16	324	8	1/8	5	1/2	444	11	3-3/8	8-1/4	7/8
5	184	215	254	40	324	364	365	200	445	—	—	—	—	—	—	—	—	—	—	—	—	445	11	3-3/8	8-1/4	7/8

① Frame numbers listed are for 110, 208, 220/440 and 550 volts. Falk™ motor mounts are pre-drilled for rerated 1964 NEMA standard foot-mounted motors.

# Engineering Data

## Overhung Load at Hollow Shaft ③

**Overhung Loads** — Overhung load is imposed upon a shaft when a pinion, sprocket or sheave is used as a power take-off. The magnitude of the load varies with the type of take-off and its proximity to the shaft bearing. Calculate the load (including minimum required service factor) and check the result against the tabulated overhung load rating. The overhung load formula below considers the transmitted horsepower without service factor. This is appropriate for applications where starting loads, momentary overloads and brake capacities do not exceed 200% of drive rating (100% overload). For other conditions, compute the equivalent power by multiplying the transmitted power by the appropriate service factor.

$$\text{Overhung Load} = \frac{126,000 \times \text{hp} \times F_c \times L_f}{\text{pitch diameter} \times \text{rpm}}$$

### F<sub>c</sub> = Load Connection Factor

Sprocket ①	1.00
Synchronous (timing) Belts.....	1.30
V-Belt.....	1.50
Machined Pinion & Gear ①.....	1.25
Flat Belt.....	2.50

### L<sub>f</sub> = Load Location Factor

Select L<sub>f</sub> from Table 6, under drive size and opposite distance from end of hollow shaft.

**Locate the centerline of the load** as close to the drive seal cage as practical to minimize the effect of the overhung load and increase bearing life.

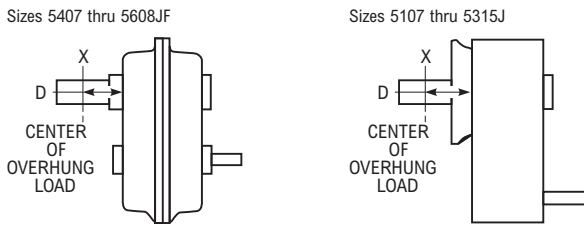

**Consult Factory for Higher Overhung Load Ratings** — In many cases, overhung load capacity in excess of that published is available. If the actual load should exceed the published capacity, refer full details to Regal Rexnord; provide complete application information (see page 6), as well as direction of rotation, location and direction of applied load.

**Example** — A chain drive requiring 10 hp is being driven by a 5207JF14, 100 rpm output, using a single-width, 21-tooth, 8.4" pitch diameter sprocket mounted on a low speed stub shaft. Centerline of the load is 4" from the output face of the housing.

**Procedure:** F<sub>c</sub> = 1.00      L<sub>f</sub> = 1.08

$$\text{Overhung Load} = \frac{126,000 \times 10 \times 1.00 \times 1.08}{8.4 \times 100} = 1620 \text{ lb}$$

Since the overhung load capacity shown for a 5207JF14 drive at 100 rpm is 2730 pounds, the application is satisfactory.

**Table 6 — Load Location Factor (L<sub>f</sub>) for Load Located at Dimension "X" Below**

Distance D ② Inches	Drive Size										
	5107	5115	5203	5207	5215	5307	5315	5407	5415	5507	5608
2	0.93	0.86	0.84	0.83	0.80	0.76	0.76				
3	1.13	0.99	0.96	0.94	0.89	0.85	0.84	0.72			
4	1.37	1.19	1.14	1.08	0.99	0.94	0.92	0.79	0.77	0.74	0.72
5	1.62	1.40	1.33	1.26	1.14	1.04	1.00	0.86	0.83	0.80	0.77
6	—	1.60	1.53	1.44	1.29	1.18	1.13	0.94	0.89	0.85	0.82
7	—	—	—	1.62	1.45	1.32	1.27	1.02	0.95	0.91	0.87
8	—	—	—	—	—	1.46	1.40	1.14	1.02	0.97	0.92
10	—	—	—	—	—	—	1.67	1.38	1.23	1.14	1.02
12	—	—	—	—	—	—	1.94	1.62	1.43	1.33	1.19
16	—	—	—	—	—	—	—	—	1.85	1.71	1.53

**Table 7 — Guide to Low-Speed Shaft Overhung Load Capacity – lb ③④**

Consult Factory for Higher Overhung Load Ratings

Drive Size	Ratios 9:1, 14:1 or 25:1										Ratio 5:1	
	Output Speed – RPM											
	10	25	50	75	100	125	150	175	90	200	300	350
Overhung Load at Dimension "X" Below												
5107	3660	2720	2150	1870	1700	1600	1520	1460	1900	1490	1310	1250
5115	4370	3240	2540	2200	1990	1850	1750	1670	2200	1720	1520	1450
5203	4170	3010	2360	2050	1860	1740	1630	1516	2020	1580	1390	1330
5207	6240	4440	3450	3000	2730	2540	2400	2280	3120	2430	2150	2050
5215	9530	6950	5420	4710	4310	4050	3860	3700	4770	3730	3300	3140
5307	8860	6300	4810	4090	3730	3470	3270	3110	4460	3470	3060	2910
5315	10000	8700	6630	5740	5260	4040	3757	3494	6190	4850	4280	4090
5407	9500	9120	6940	5940	5370	4960	—	—	6010	4620	4090	3910
5415	15000	13210	10080	8610	7750	7160	—	—	9190	7200	6370	6070
5507	Refer to Factory							—	—	—	—	—
5608	Refer to Factory							—	—	—	—	—

## Driven Shaft Diameter Tolerances

Shaft diameters shall be within commercial tolerances for turned and polished round bars as shown below.

Shaft Diameter	Maximum Undersize Variation – Inches
to 1.50	0.004
over 1.50 to 2.50 incl.	0.005
over 2.50 to 4 incl.	0.006
over 4 to 6 incl.	0.007
over 6 to 8 incl.	0.008

Keys and keyways in the supporting shaft shall be in accordance with ANSI B17.1 for size, depth, offset, lead and parallelism.

- ① Refer all multiple chain sprocket and pinion mounted applications to Regal Rexnord for deflection analysis.
- ② Distance "D" is in inches from the output face of the housing. Interpolate for L<sub>f</sub> factors at intermediate distances. For example, L<sub>f</sub> is 1.11 for Size 5307 when distance is 5.50 inches. Refer to Factory for distances greater than those shown.
- ③ For JF Flanged Mounted Drives, the TA Taper bushing, using the spanner nut, is not intended to provide the full external load capacities given in Table 7 and Table 8. Use the tapered driven shafts manufactured per Manual 377-140, or non-tapered driven shafts and bushings per Manual 377-142 (5107-5315JF) & 377-144 (5407-5608JF), or refer your application to Factory for review.
- ④ Published values of low-speed shaft overhung load are for loads applied one shaft diameter from the seal cage with a service factor of unity. Where overhung load is proportional to torque (i.e. pinion, sprocket or sheave applications) an appropriate service factor should be considered in the overhung load calculation.

# Engineering Data

Sizes 5107 thru 5315JF

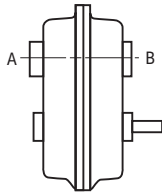

Sizes 5407 thru 5608JF

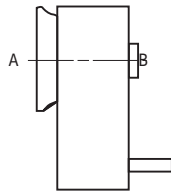

## Thrust at Hollow Shaft

The capacities in Table 8 are for PURE thrust loads for either direction of shaft rotation. Higher values are listed in Manual 377-115 for specific shaft rotations. When both radial and thrust loads are involved, refer application details to the Factory.

**Table 8 — Guide to Pure Thrust Capacity at Hollow Shaft (lb)**

JF & JFV Drive Size	Ratios 9:1, 14:1 or 25:1												Ratio 5:1				JF & JFV Drive Size	Ratios 9:1, 14:1 or 25:1												Ratio 5:1			
	Output Speed – RPM												Output Speed – RPM					Output Speed – RPM												Output Speed – RPM			
	10	25	50	75	100	125	150	175	90	200	300	350	10	25	50	75		100	125	150	175	90	200	300	350								
Thrust: A towards B													Thrust: B towards A																				
5107	3590	2840	2150	1820	1620	1540	1470	1420	2060	1610	1410	1350	5107	3490	2840	2160	1820	1620	1540	1470	1420	2060	1610	1410	1350								
5115	4390	4390	4350	3680	3250	3020	2860	2730	3920	3060	2700	2570	5115	3490	3490	3490	3490	3270	3040	2870	2740	3490	3070	2700	2580								
5203	6680	5680	4310	3670	3290	3060	2850	2720	3800	2940	2580	2460	5203	5590	5590	4410	3760	3380	3150	2940	2800	3880	3000	2640	2510								
5207	8120	7750	5760	4930	4450	4120	3860	3640	5600	4340	3830	3660	5207	5590	5590	5590	5100	4610	4240	4000	3780	5590	4440	3920	3740								
5215	10180	10180	9900	8440	7690	7270	6960	6720	9130	7120	6260	5980	5215	8170	8170	8170	8170	7900	7460	7140	6890	8170	7250	6380	6090								
5307	13160	11010	8240	6750	6100	5640	5300	5010	8440	6500	5690	5410	5307	10770	10770	8640	7080	6410	5940	5570	5270	8660	6680	5850	5560								
5315	13220	8470	6070	5050	4660	4370	4064	3780	5910	4660	4100	3420	5315	13680	8640	6230	5260	4830	4530	4213	3918	6060	4780	4280	4020								
5407	13000	9810	6320	5520	4890	4370	—	—	6230	4830	4270	4070	5407	12210	9890	6900	5600	4960	4440	—	—	6290	4730	4190	4010								
5415	16400	16400	14730	12100	10630	9630	—	—	14590	11400	10070	9590	5415	18980	18980	14730	12100	10630	9680	—	—	14590	11200	9990	9530								
5507	6000	6000	6000	6000	6000	6000	—	—	—	—	—	—	5507	20580	20580	15230	13190	12160	11420	—	—	—	—	—	—								
5608	14800	14800	14800	14300	13425	12554	—	—	—	—	—	—	5608	29000	23580	15810	13990	13122	12271	—	—	—	—	—	—								

**Table 9 — WR<sup>2</sup> (lb-in<sup>2</sup>) Referred to H.S. Shaft**

Drive Size	Ratio			
	5:1	9:1	14:1	25:1
5107	1.37	1.28	0.83	0.43
5115	3.45	3.14	2.08	1.07
5203	7.03	5.94	3.59	2.00
5207	15.01	12.86	8.34	4.70
5215	39.02	35.69	19.57	10.92
5307	70.67	63.63	34.96	20.82
5315	82.89	72.42	47.18	28.62
5407	171.83	—	74.86	41.94
5415	275.77	—	140.58	74.51
5507	—	—	262.79	137.81
5608	—	—	457.90	232.40

Table 9 — Values shown in Table 9 above are referred to the drive high-speed shaft. The WR<sup>2</sup> referred to the hollow (low-speed) shaft equals the exact total ratio squared times the H.S. shaft WR<sup>2</sup>. Refer to Factory for values of unlisted ratios and drive sizes.

Table 10 — Minimum sheave diameters listed in Table 2 & Table 3 are for V-belt drives with the load applied one shaft diameter from the seal cage or from the fan guard, if equipped with a shaft cooling fan. For minimum sheave diameters for loads applied at a greater distance, multiply the published minimum sheave diameter by the load location factor (from Table 10) for the “distance” required. When using chains or timing belts, multiply minimum sheave diameters by 0.66.

**Table 10 — H.S. Shaft Load Location Factors**

Distance D in Inches ①	Drive Size											
	5107	5115	5203	5207	5215	5307	5315	5407	5415	5507	5608	
0.500	0.94											
0.750	0.98	0.95										
0.875	1.00	0.97										
1.000	1.05	0.98	0.95									
1.125	1.11	1.00	0.96	0.95								
1.250	1.16	1.05	0.98	0.97								
1.375	1.21	1.09	1.00	0.98	0.95							
1.500	1.27	1.14	1.04	1.00	0.96	0.94	0.93					
1.750	1.37	1.24	1.11	1.07	0.99	0.96	0.95	0.93	0.94			
1.875	1.43	1.28	1.15	1.10	1.00	0.98	0.96	0.94	0.95			
2.000	1.48	1.33	1.19	1.14	1.03	0.99	0.98	0.96	0.96	0.95	0.94	
2.125	—	1.38	1.23	1.17	1.06	1.00	0.99	0.97	0.97	0.96	0.94	
2.250	—	1.43	1.26	1.20	1.09	1.03	1.00	0.98	0.98	0.96	0.95	
2.500	—	1.52	1.34	1.27	1.15	1.08	1.05	1.00	1.00	0.98	0.97	
2.750	—	—	1.41	1.34	1.21	1.13	1.10	1.05	1.05	1.00	0.98	
3.000	—	—	1.49	1.41	1.27	1.19	1.15	1.11	1.10	1.05	1.00	
3.250	—	—	—	1.47	1.33	1.24	1.20	1.16	1.14	1.09	1.04	
3.500	—	—	—	1.54	1.39	1.30	1.25	1.21	1.19	1.14	1.09	
3.750	—	—	—	—	1.45	1.35	1.30	1.26	1.24	1.18	1.13	
4.000	—	—	—	—	1.51	1.40	1.35	1.32	1.29	1.23	1.17	
4.250	—	—	—	—	—	1.46	1.40	1.37	1.34	1.27	1.21	
4.500	—	—	—	—	—	1.51	1.45	1.42	1.38	1.32	1.26	
4.750	—	—	—	—	—	—	1.50	1.48	1.43	1.37	1.30	
5.000	—	—	—	—	—	—	1.55	1.53	1.48	1.41	1.34	
5.250	—	—	—	—	—	—	—	1.58	1.53	1.46	1.39	
5.500	—	—	—	—	—	—	—	1.63	1.58	1.50	1.43	
5.750	—	—	—	—	—	—	—	1.69	1.62	1.55	1.47	
6.000	—	—	—	—	—	—	—	1.74	1.67	1.60	1.51	
6.250	—	—	—	—	—	—	—	—	1.72	1.64	1.56	
6.500	—	—	—	—	—	—	—	—	—	1.69	1.60	
6.750	—	—	—	—	—	—	—	—	—	—	1.73	1.64
7.000	—	—	—	—	—	—	—	—	—	—	1.78	1.69
7.250	—	—	—	—	—	—	—	—	—	—	1.82	1.73
7.500	—	—	—	—	—	—	—	—	—	—	1.87	1.77
7.750	—	—	—	—	—	—	—	—	—	—	—	1.81
8.000	—	—	—	—	—	—	—	—	—	—	—	1.86
8.250	—	—	—	—	—	—	—	—	—	—	—	1.90

① Distance “D” is in inches from the input face of the H.S. seal cage. Interpolate for load location factors at intermediate distances. For example, the load location factor is 1.27 for Size 5307 when distance is 3.375 inches. Refer to Factory for distances greater than those shown.

# Size 5107 Shaft-Mounted (JR) & Flange-Mounted (JF) Drive

## Dimensions (in) <sup>①</sup>

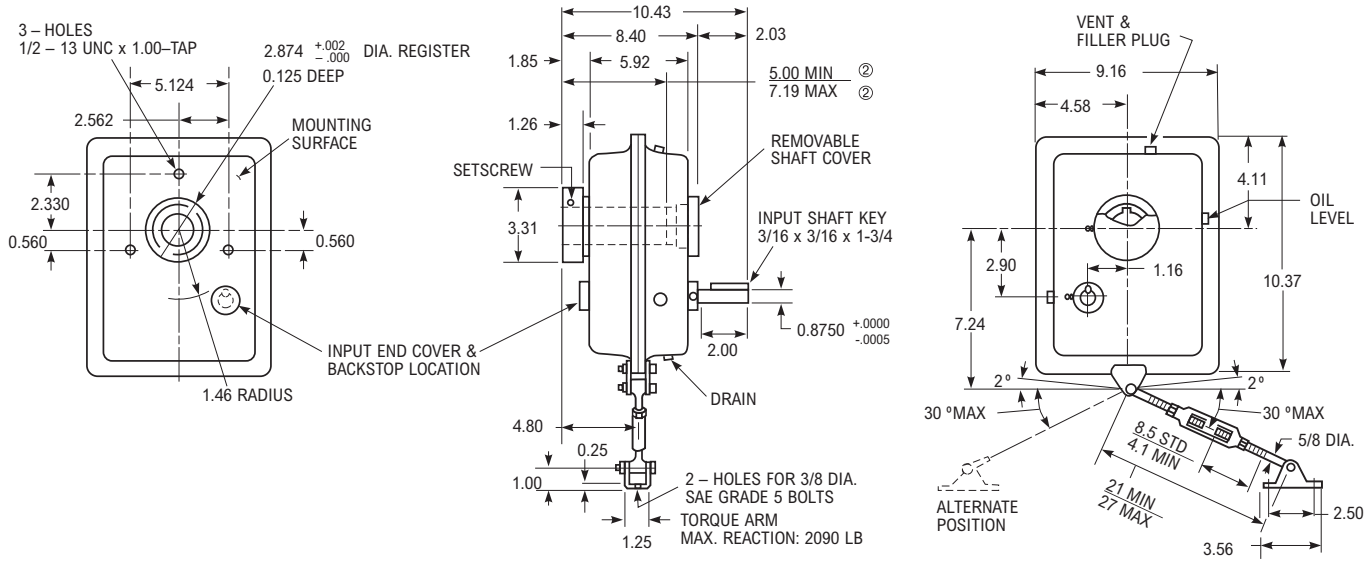

## Hollow Shaft Details

See Manual 377-140 for JF drive tapered driven shaft recommendations. See Manual 377-142 for JF drives using tapered bushings.

## Angular Limits for Horizontal Mounting

(All Clock Positions)

Refer to Factory for lubrication analysis of all inclined drives exceeding the maximum specified below. Also for drives with combined incline down and rotation.

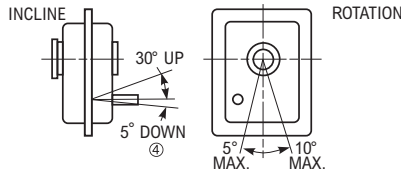

Basic Drive Size <sup>③</sup>	Part Number	Exact Ratio	Max Output RPM	Wt (lb)
5107J05A	0793781	5.077	350	55
5107J09A	0793782	9.462	190	60
5107J14A	0793783	14.43	125	60
5107J25A	0793784	25.81	70	60

## TA Taper Bushings

### Style No. 1 — Thin-wall bushing

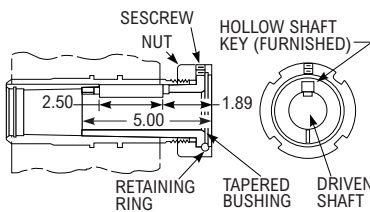

### Style No. 2 — Thick-wall bushing

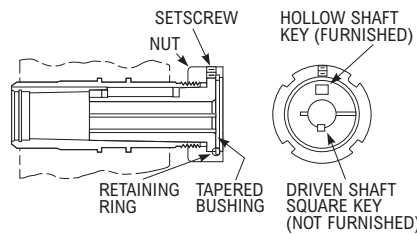

Bushing Size	Part Number <sup>⑤</sup>	Style No.	Driven Shaft Keyway/Min Key Length <sup>⑥</sup>	Wt (lb)
BU5107J-1.000	0769061	2	1/4 x 1/8 x 2-1/2	2.1
BU5107J-1.125	0769062	2	1/4 x 1/8 x 2-1/4	1.8
BU5107J-1.188	0769063	2	1/4 x 1/8 x 2	1.6
BU5107J-1.250	0769064	1	1/4 x 1/8 x 2-1/2	1.5
BU5107J-1.375	6720659	1	3/8 x 3/16 x 2-1/2	1.0
BU5107J-1.438	0769065	1	3/8 x 3/16 x 2-1/2	1.0

## Accessories

Torque Arm

TA5107J  
PN 0785261  
Wt. 4 lb

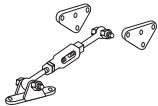

Backstop

BS5107J05/09/14  
PN 0795654  
BS5107J25  
PN 0795655  
Wt. 1 lb



Thrust Plate Kit

TP5107J  
PN 0769060  
Wt. 1 lb



- ① Dimensions are for reference only and are subject to change without notice unless certified.
- ② MIN = Minimum required projection of driven shaft. MAX = Maximum projection of driven shaft which allows for use of thrust plate.
- ③ JR = Basic Drive + Bushing + Torque Arm  
JF = Basic Drive (Bushings Optional)  
JSC = Basic Drive + Seal Housing + Driveshaft
- ④ 0° incline down on drives with backstops in 9 or 12 o'clock mounting.
- ⑤ Consists of bushing, drive key, nut, retaining ring and setscrew.
- ⑥ Check strength of driven shaft and unfurnished key.



# Size 5115 Shaft-Mounted (JR) & Flange-Mounted (JF) Drive

## Dimensions (in) <sup>①</sup>

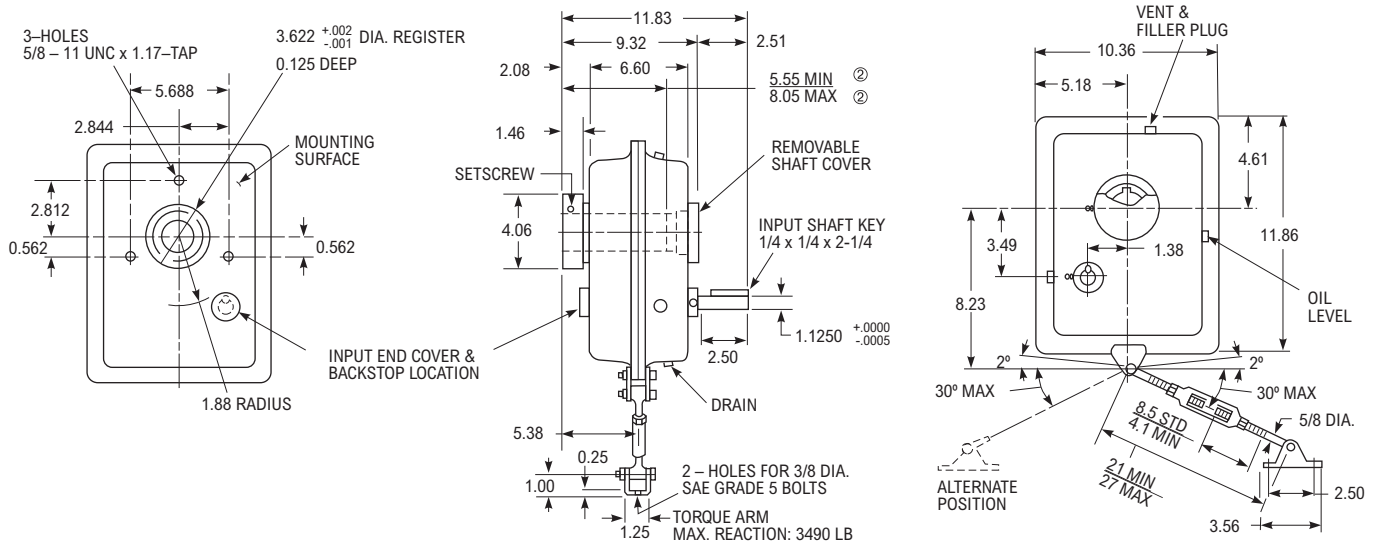

## Hollow Shaft Details

See Manual 377-140 for JF drive tapered driven shaft recommendations. See Manual 377-142 for JF drives using tapered bushings.

## Angular Limits for Horizontal Mounting

(All Clock Positions)

Refer to Factory for lubrication analysis of all inclined drives exceeding the maximum specified below. Also for drives with combined incline down and rotation.

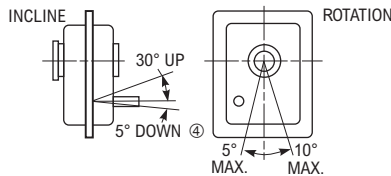

Basic Drive Size <sup>③</sup>	Part Number	Exact Ratio	Max Output RPM	Wt (lb)
5115J05A	0793858	5.053	350	85
5115J09A	0793859	9.357	190	90
5115J14A	0793860	13.95	125	90
5115J25A	0793861	24.87	70	90

## TA Taper Bushings

### Style No. 1 — Thin-wall bushing

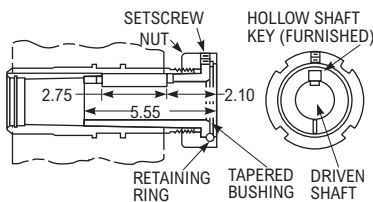

### Style No. 2 — Thick-wall bushing

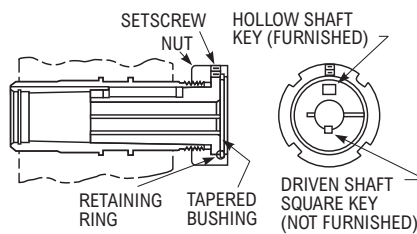

Bushing Size	Part Number <sup>⑤</sup>	Style No.	Driven Shaft Keyway/Min Key Length <sup>⑥</sup>	Wt (lb)
BU5115J-1.188	0769077	2	1/4 x 1/8 x 4-1/4	4.3
BU5115J-1.250	0769078	2	1/4 x 1/8 x 4	4.1
BU5115J-1.438	0769079	2	3/8 x 3/16 x 2-1/4	3.5
BU5115J-1.500	0769080	2	3/8 x 3/16 x 2-1/4	3.3
BU5115J-1.625	0769081	1	3/8 x 3/16 x 2-3/4	2.9
BU5115J-1.688	0769082	1	3/8 x 3/16 x 2-3/4	2.7
BU5115J-1.750	0769083	1	3/8 x 3/16 x 2-3/4	2.4
BU5115J-1.938	0769084	1	1/2 x 1/4 x 2-3/4	1.7

## Accessories

Torque Arm

TA5115J  
PN 0785261  
Wt. 4 lb

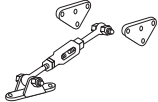

Backstop

BS5115J05/09/14  
PN 0793995  
BS5115J25  
PN 0795658  
Wt. 1 lb



Thrust Plate Kit

TP5115J  
PN 0769076  
Wt. 1 lb



- ① Dimensions are for reference only and are subject to change without notice unless certified.
- ② MIN = Minimum required projection of driven shaft. MAX = Maximum projection of driven shaft which allows for use of thrust plate.
- ③ JR = Basic Drive + Bushing + Torque Arm  
JF = Basic Drive (Bushing Optional)  
JSC = Basic Drive + Seal Housing + Driveshaft
- ④ 0° incline down on drives with backstops in 9 or 12 o'clock mounting.
- ⑤ Consists of bushing, drive key, nut, retaining ring and setscrew.
- ⑥ Check strength of driven shaft and unfurnished key.



## Size 5115 Screw Conveyor (JSC) Drive (continued)

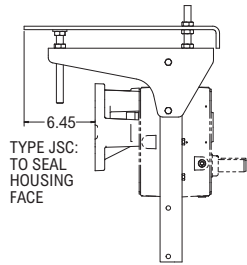
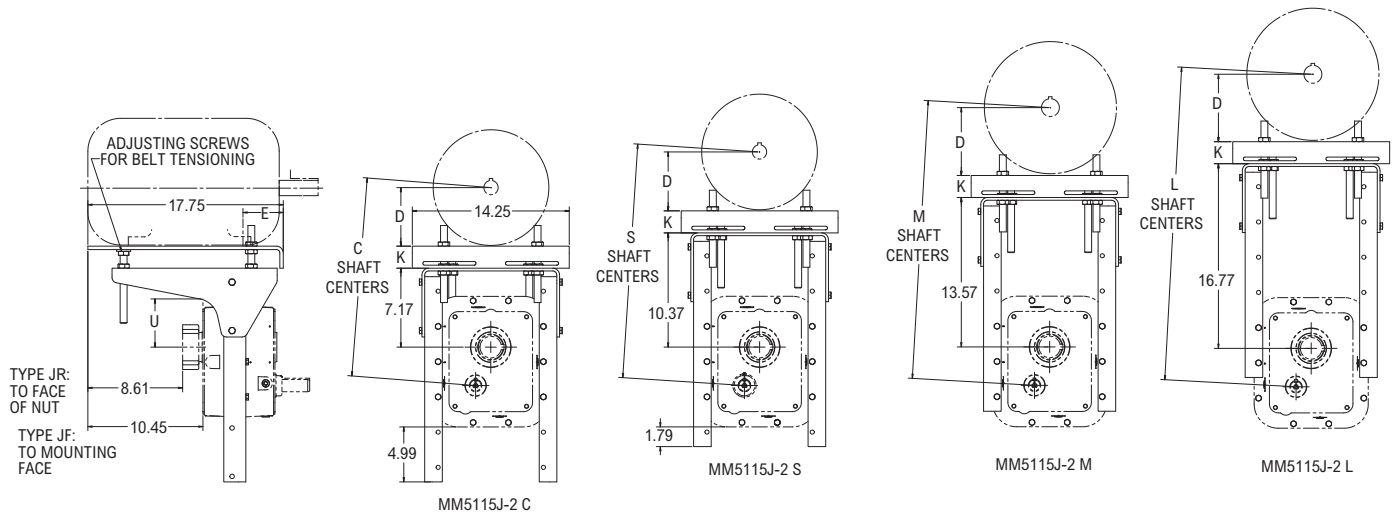

Frame	-1				-2					
	56	143-145T	182-184T	213-215T	254-256T					
D	3.50	3.50	4.50	5.25	6.25					
E	3.04	2.54	2.96	3.74	4.87					
Shaft Centers	Min-Max		Min-Max		Min-Max					
(C) Compact	15.7	19.6	15.7	19.6	16.7	20.6	17.4	21.4	18.6	22.9
(S) Short	18.9	22.8	18.9	22.8	19.9	23.8	20.6	24.6	21.8	26.1
(M) Medium	22.1	26.0	22.1	26.0	23.1	27.0	23.8	27.8	25.0	29.3
(L) Long	25.3	29.2	25.3	29.2	26.3	30.2	27.0	30.9	28.2	32.5

### Dimensions (in)

Motor Mount Size ⑥	Part Number	Type T Frame ⑦		K		U				Motor Mount Wt (lb)
		Min	Max	Min	Max	Compact	Short	Med	Long	
MM5115J-1 CSML	7708120	56	215	1.37	5.25	4.38	7.58	10.78	13.98	37.0
MM5115J-2 CSML	7708122	254	256	1.66	6.00	4.38	7.58	10.78	13.98	44.9

- ① Dimensions are for reference only and are subject to change without notice unless certified.
- ② Hexagon head screws with UNC thread are furnished by Regal Rexnord for mounting the gear drive to the trough end.
- ③ Shaft diameters under 3" are held to limits of +.000", -.002". Shaft diameters 3" and over are held to limits of +.000", -.003".
- ④ See page 49 for optional 316 stainless steel driveshafts – stocked.
- ⑤ Check driveshaft torque & bending capacity and coupling bolt shear & bearing stresses against load to be transmitted. See above drawing for location of third driveshaft-coupling bolt hole if required.
- ⑥ Dimensions are for reference only and are subject to change without notice unless certified. When determining belt length for minimum shaft centers, follow the belt manufacturer's installation allowance recommendations.
- ⑦ Refer to Manual 377-820 for standard vertical assemblies and all Type U frame motor limits.
- ⑧ Refer to Factory for alternate drive assembly dimensions.

# Size 5203 Shaft-Mounted (JR) & Flange-Mounted (JF) Drive

## Dimensions (in) <sup>①</sup>

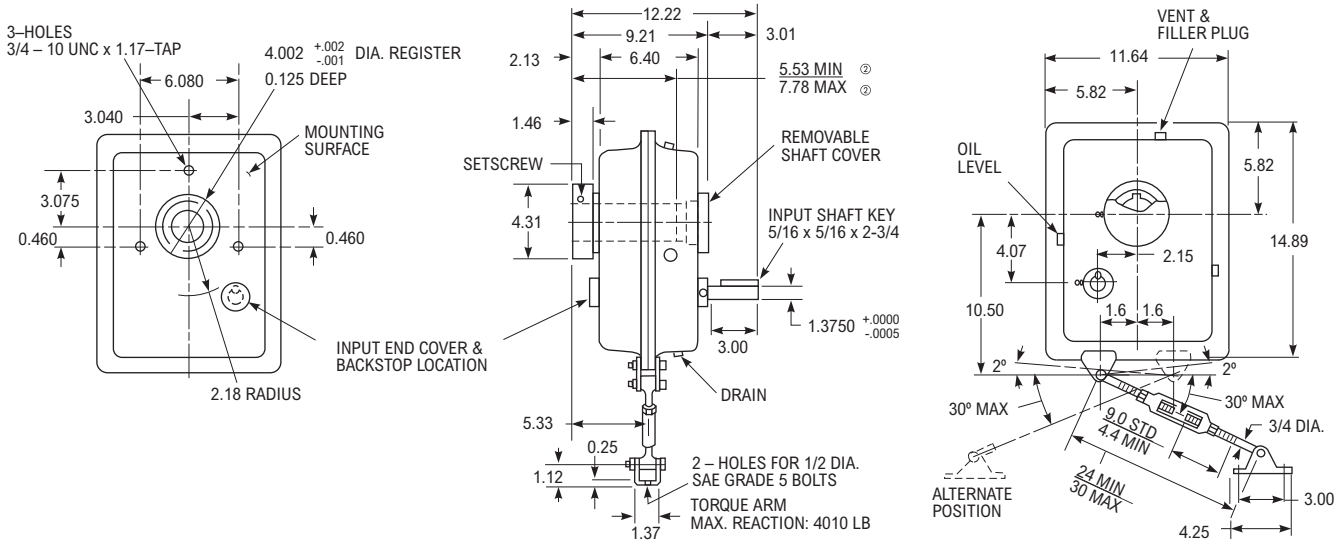

## Hollow Shaft Details

See Manual 377-140 for JF drive tapered driven shaft recommendations. See Manual 377-142 for JF drives using tapered bushings.

## Angular Limits for Horizontal Mounting

(All Clock Positions)

Refer to Factory for lubrication analysis of all inclined drives exceeding the maximum specified below. Also for drives with combined incline down and rotation.

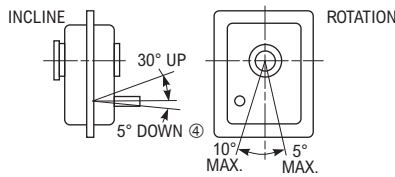

Basic Drive Size <sup>③</sup>	Part Number	Exact Ratio	Max Output RPM	Wt (lb)
5203J05A	0794374	5.071	350	110
5203J09A	0794375	9.179	190	115
5203J14A	0794376	14.452	125	115
5203J25A	0794377	26.942	70	115

## TA Taper Bushings

### Style No. 1 — Thin-wall bushing

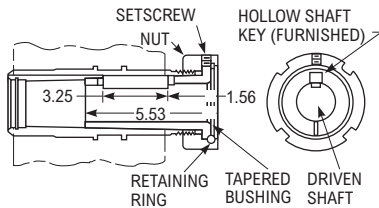

### Style No. 2 — Thick-wall bushing

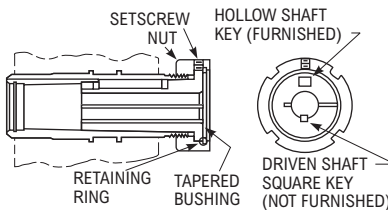

Bushing Size	Part Number <sup>⑤</sup>	Style No.	Driven Shaft Keyway/Min Key Length <sup>⑥</sup>	Wt (lb)
BU5203J-1.438	0769117	2	3/8 x 3/16 x 3-1/4	5.0
BU5203J-1.500	0769118	2	3/8 x 3/16 x 3-1/4	5.1
BU5203J-1.625	0769119	2	3/8 x 3/16 x 3	4.6
BU5203J-1.688	0769120	2	3/8 x 3/16 x 2-3/4	4.4
BU5203J-1.750	0769121	2	1/2 x 1/4 x 2-3/4	4.4
BU5203J-1.875	0769122	1	1/2 x 1/4 x 3-1/4	3.6
BU5203J-1.938	0769123	1	1/2 x 1/4 x 3-1/4	3.3
BU5203J-2.000	0769124	1	1/2 x 1/4 x 3-1/4	3.0
BU5203J-2.188	0769125	1	1/2 x 1/4 x 3-1/4	3.0

## Accessories

Torque Arm

TA5203J  
 PN 0785263  
 Wt. 6 lb

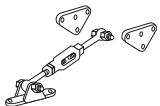

Backstop

BS5203J05/09/14/25  
 PN 0785596  
 Wt. 1 lb



Thrust Plate Kit

TP5203J  
 PN 0769116  
 Wt. 1 lb



- ① Dimensions are for reference only and are subject to change without notice unless certified.
- ② MIN = Minimum required projection of driven shaft. MAX = Maximum projection of driven shaft which allows for use of thrust plate.
- ③ JR = Basic Drive + Bushing + Torque Arm  
 JF = Basic Drive (Bushings Optional)  
 JSC = Basic Drive + Seal Housing + Driveshaft
- ④ 0° incline down on drives with backstops in 9 or 12 o'clock mounting.
- ⑤ Consists of bushing, drive key, nut, retaining ring and setscrew.
- ⑥ Check strength of driven shaft and unfurnished key.

# Size 5203 Screw Conveyor (JSC) Drive

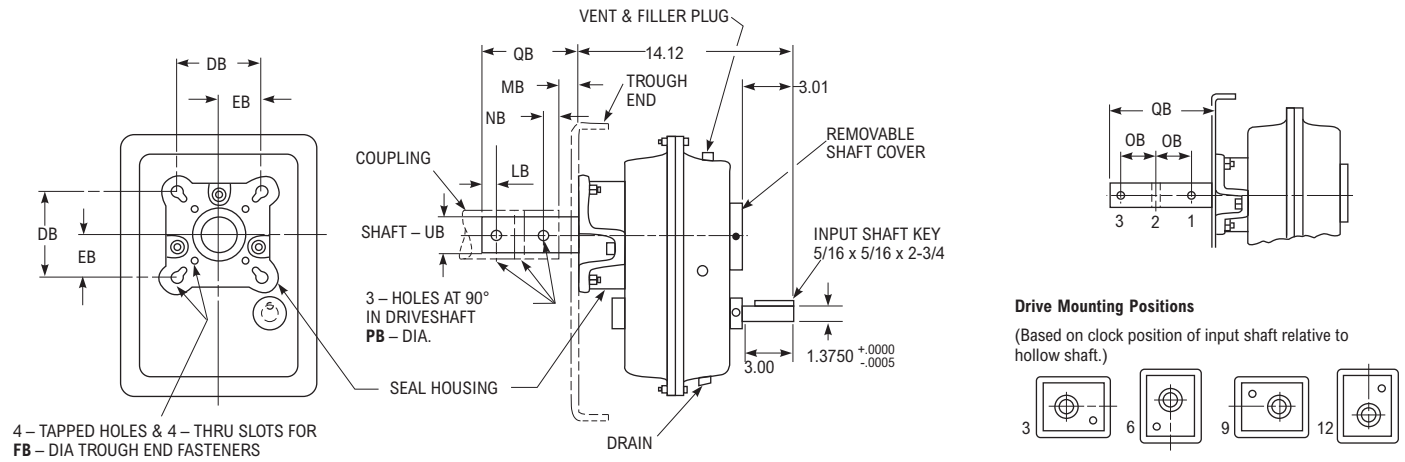

### Drive Mounting Positions

(Based on clock position of input shaft relative to hollow shaft.)

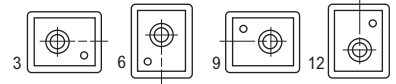

### Dimensions (in) ①

Basic Drive Size ①	Screw Conveyor Components										DB	EB	FB ②	LB	MB	NB	OB	PB	QB	UB ③
	Cplg Dia	Screw Dia	Max Tq (lb-in)	Driveshaft w/Thrust Plane ④	Part No.	Wt (lb)	Seal Housing	Part No.	Wt (lb)											
5203	1.500	6, 9	5,200	DS5203J-1.500 ⑤	6720016	16	SH5203J	0769114	15	4.000	2.000	0.500	0.875	1.250	0.875	3.000	0.531	9.000 ⑤	1.500	
	2.000	9, 12	10,200	DS5203J-2.000 ⑤	6720017	20	SH5203J	0769114	15	5.125	2.562	0.625	0.875	1.250	0.875	3.000	0.656	9.000 ⑤	2.000	
	2.437	12, 14	13,100	DS5203J-2.437	6720018	21	SH5203J	0769114	15	5.625	2.812	0.625	0.938	1.812	0.938	3.000	0.656	9.688	2.437	
	3.000	12-20	14,600	DS5203J-3.000	6720019	26	SH5203J	0769114	15	6.000	3.000	0.750	1.000	1.875	1.000	3.000	0.781	9.875	3.000	

### Trough End Seals

Lip Seal	Packing Gland Seal Kit
PN 2911847	PGSK5203J
Wt. 1 lb	PN 0769115
	Wt. 1 lb

### Motor Mounts

Standard Horizontal Drive Assembly – (6 o'clock shown) (3-9-12 o'clock optional with limitations, see note 8.)

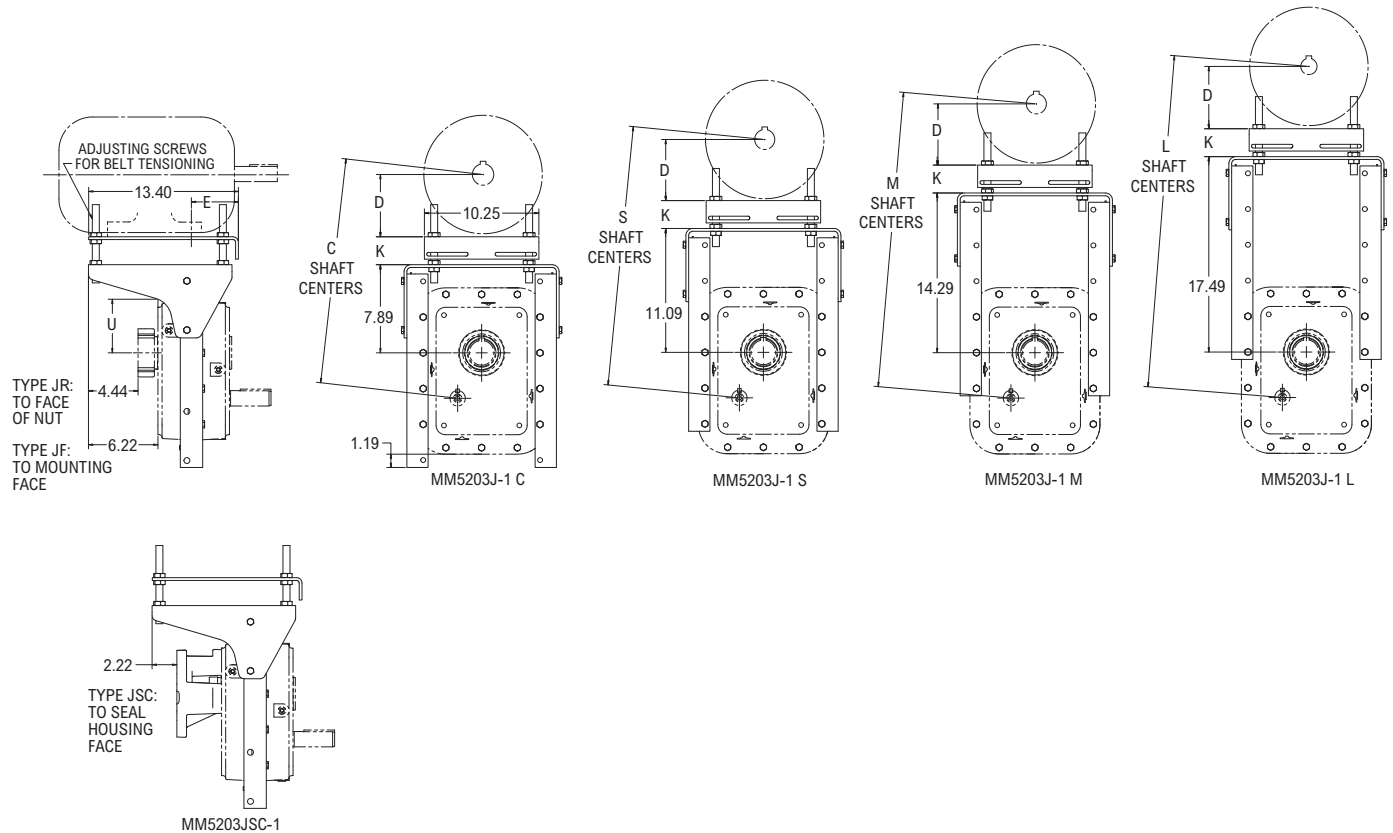

## Size 5203 Screw Conveyor (JSC) Drive (continued)

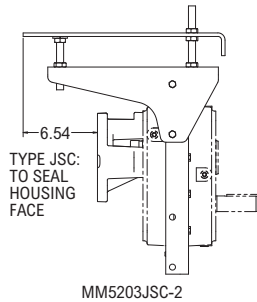
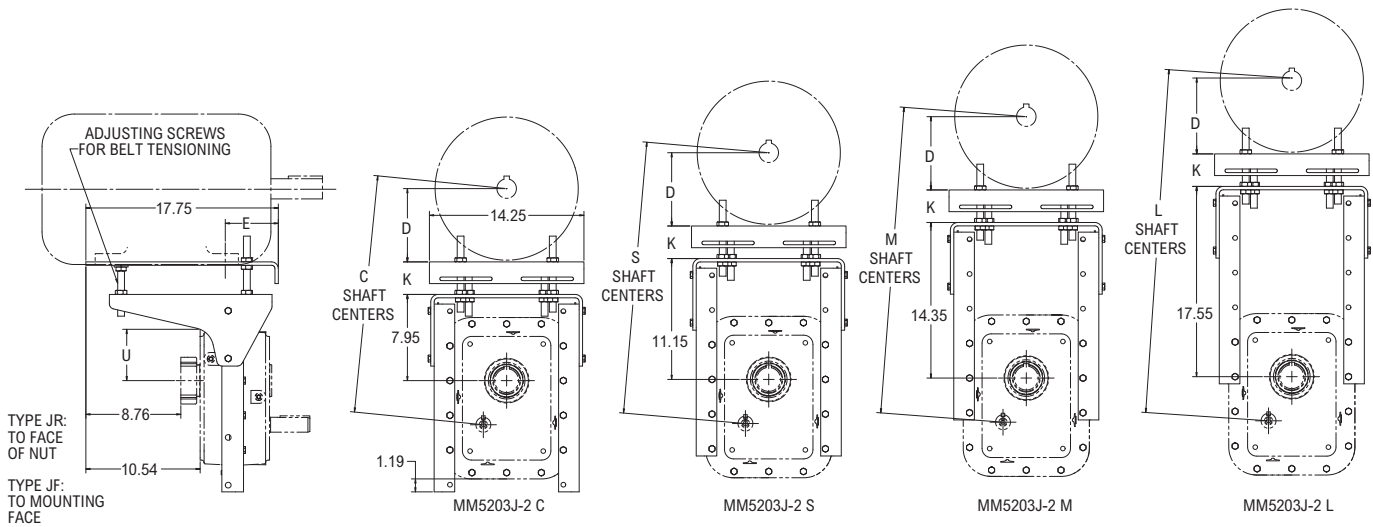

Frame	-1				-2	
	56	143-145T	182-184T	213-215T	254-256T	284-286T
D	3.50	3.50	4.50	5.25	6.25	7.00
E	2.50	2.00	2.50	3.74	4.87	5.24
Shaft Centers	Min-Max	Min-Max	Min-Max	Min-Max	Min-Max	Min-Max
(C) Compact	16.9 20.8	16.9 20.8	17.9 21.8	18.6 22.5	19.9 24.2	20.6 24.9
(S) Short	20.1 24.0	20.1 24.0	21.1 25.0	21.8 25.7	23.1 27.4	23.8 28.1
(M) Medium	23.2 27.2	23.2 27.2	24.2 28.2	25.0 28.9	26.3 30.6	27.0 31.3
(L) Long	26.4 30.4	26.4 30.4	27.4 31.4	28.2 32.1	29.4 33.8	30.2 34.5

### Dimensions (in)

Motor Mount Size ⑥	Part Number	Type T Frame ⑦		K		U				Motor Mount Wt (lb)
		Min	Max	Min	Max	Compact	Short	Med	Long	
MM5203J-1 CSML	7708124	56	215	1.37	5.25	4.80	8.00	11.20	14.40	40.1
MM5203J-2 CSML	7708126	254	286	1.68	6.00	4.73	7.93	11.13	14.33	48.0

- ① Dimensions are for reference only and are subject to change without notice unless certified.
- ② Hexagon head screws with UNC thread are furnished by Regal Rexnord for mounting the gear drive to the trough end.
- ③ Shaft diameters under 3" are held to limits of +.000", -.002". Shaft diameters 3" and over are held to limits of +.000", -.003".
- ④ See page 49 for optional 316 stainless steel driveshafts – stocked.
- ⑤ Check driveshaft torque & bending capacity and coupling bolt shear & bearing stresses against load to be transmitted. See above drawing for location of third driveshaft-coupling bolt hole if required.
- ⑥ Dimensions are for reference only and are subject to change without notice unless certified. When determining belt length for minimum shaft centers, follow the belt manufacturer's installation allowance recommendations.
- ⑦ Refer to Manual 377-820 for standard vertical assemblies and all Type U frame motor limits.
- ⑧ Refer to Factory for alternate drive assembly dimensions.

# Size 5207 Shaft-Mounted (JR) & Flange-Mounted (JF) Drive

## Dimensions (in) <sup>①</sup>

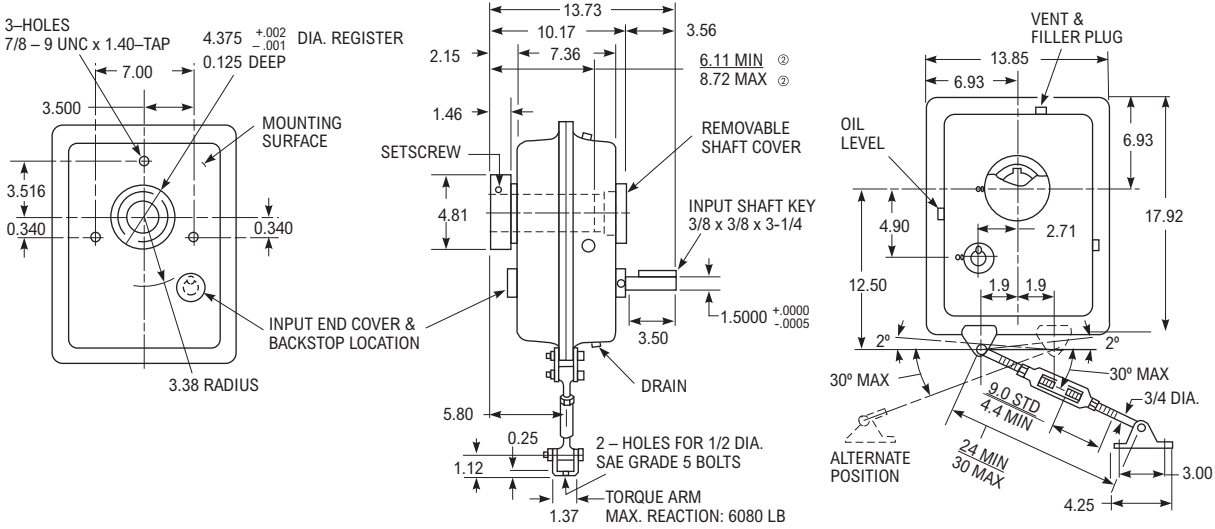

## Hollow Shaft Details

See Manual 377-140 for JF drive tapered driven shaft recommendations. See Manual 377-142 for JF drives using tapered bushings.

## Angular Limits for Horizontal Mounting

(All Clock Positions)

Refer to Factory for lubrication analysis of all inclined drives exceeding the maximum specified below. Also for drives with combined incline down and rotation.

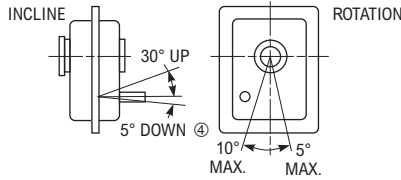

Basic Drive Size <sup>③</sup>	Part Number	Exact Ratio	Max Output RPM	Wt (lb)
5207J05A	0794378	5.077	350	180
5207J09A	0794379	9.492	190	190
5207J14A	0794380	14.47	125	190
5207J25A	0794381	24.99	70	190

## TA Taper Bushings

### Style No. 1 — Thin-wall bushing

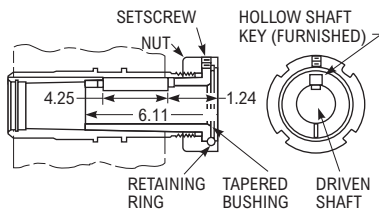

### Style No. 2 — Thick-wall bushing

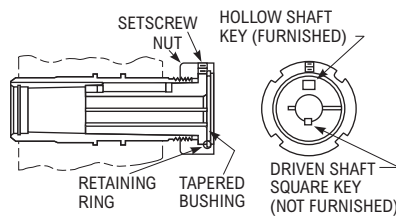

Bushing Size	Part Number <sup>⑤</sup>	Style No.	Driven Shaft Keyway/Min Key Length <sup>⑥</sup>	Wt (lb)
BU5207J-1.375	0769095	2	3/16 x 5/32 x 5-3/4	7.6
BU5207J-1.438	0769096	2	3/8 x 3/16 x 5-3/4	7.3
BU5207J-1.500	0769097	2	3/8 x 3/16 x 5-3/4	7.1
BU5207J-1.625	0765848	2	3/8 x 3/16 x 5-3/4	6.7
BU5207J-1.688	0769098	2	3/8 x 3/16 x 5-1/4	6.4
BU5207J-1.750	0769099	2	3/8 x 3/16 x 5-1/4	6.1
BU5207J-1.875	0769100	2	1/2 x 1/4 x 3-1/2	5.6
BU5207J-1.938	0769101	1	1/2 x 1/4 x 4-1/4	5.3
BU5207J-2.000	0769102	1	1/2 x 1/4 x 4-1/4	5.0
BU5207J-2.188	0769103	1	1/2 x 1/4 x 4-1/4	4.4
BU5207J-2.250	0769104	1	1/2 x 1/4 x 4-1/4	3.7
BU5207J-2.375	2113886	1	5/8 x 5/16 x 4-1/4	3.0
BU5207J-2.438	0769105	1	5/8 x 5/16 x 4-1/4	2.6

## Accessories

### Torque Arm

TA5207J  
PN 0785265  
Wt. 7 lb

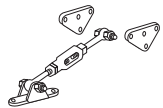

### Backstop

BS5207J05/09/14/25  
PN 0783905  
Wt. 2 lb



### Thrust Plate Kit

TP5207J  
PN 0769094  
Wt. 1 lb



- ① Dimensions are for reference only and are subject to change without notice unless certified.
- ② MIN = Minimum required projection of driven shaft. MAX = Maximum projection of driven shaft which allows for use of thrust plate.
- ③ JR = Basic Drive + Bushing + Torque Arm  
JF = Basic Drive (Bushings Optional)  
JSC = Basic Drive + Seal Housing + Driveshaft
- ④ 0° incline down on drives with backstops in 9 or 12 o'clock mounting.
- ⑤ Consists of bushing, drive key, nut, retaining ring and setscrew.
- ⑥ Check strength of driven shaft and unfurnished key.

# Size 5207 Screw Conveyor (JSC) Drive

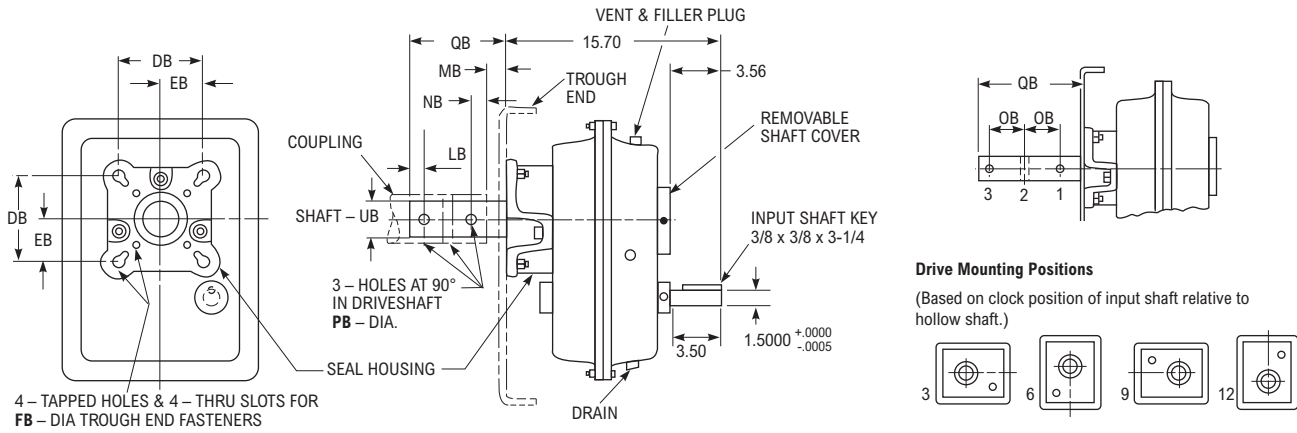

## Dimensions (in) ①

Basic Drive Size ①	Screw Conveyor Components										DB	EB	FB ②	LB	MB	NB	OB	PB	QB	UB ③
	Cplg Dia	Screw Dia	Max Tq (lb-in)	Driveshaft w/Thrust Plane ④	Part No.	Wt (lb)	Seal Housing	Part No.	Wt (lb)											
5207	1.500	9	5,200	DS5207J-1.500 ⑤	6720020	20	SH5207J	0769092	25	5.125 ⑥	2.562 ⑥	0.500	0.875	1.250	0.875	3.000	0.531	9.000 ⑥	1.500	
	2.000	9, 12	12,200	DS5207J-2.000 ⑤	6720021	24	SH5207J	0769092	25	5.125	2.562	0.625	0.875	1.250	0.875	3.000	0.656	9.000 ⑥	2.000	
	2.437	12, 14	13,150	DS5207J-2.437 ⑤	6720022	29	SH5207J	0769092	25	5.625	2.812	0.625	0.938	1.812	0.938	3.000	0.656	9.688 ⑥	2.437	
	3.000	12-20	23,300	DS5207J-3.000	6720023	30	SH5207J	0769092	25	6.000	3.000	0.750	1.000	1.875	1.000	3.000	0.781	9.875	3.000	
	3.437	18-24 ⑦	23,300	DS45207J-3.437	6720024	34	SH5207J	0769092	25	6.000 ⑥	3.000 ⑥	0.750	1.250	2.375	1.500	4.000	0.906	13.437	3.437	

## Trough End Seals

Lip Seal

PN 0912835

Wt. 1 lb

Packing Gland Seal Kit

PGSK5207J

PN 0769093

Wt. 1 lb

## Motor Mounts

Standard Horizontal Drive Assembly – (6 o'clock shown) (3-9-12 o'clock optional with limitations, see note 10.)

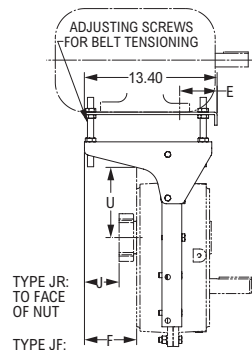

MM5207J-1 S

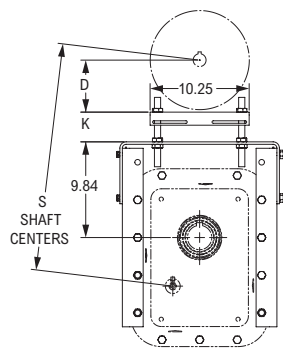

MM5207J-1 M

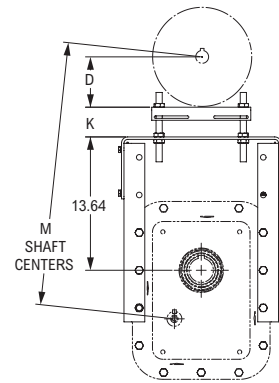

MM5207J-1 L

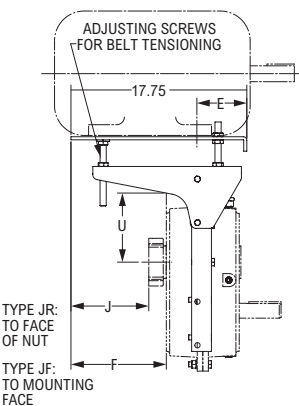

MM5207J-2 S

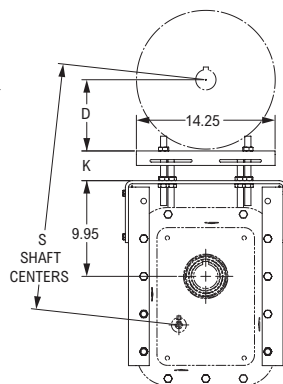

MM5207J-2 M

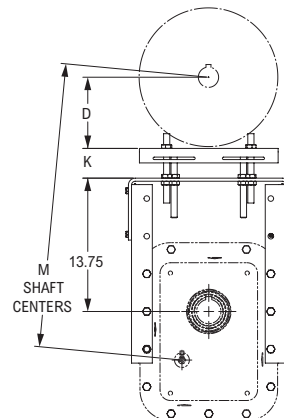

MM5207J-2 L

## Size 5207 Screw Conveyor (JSC) Drive (continued)

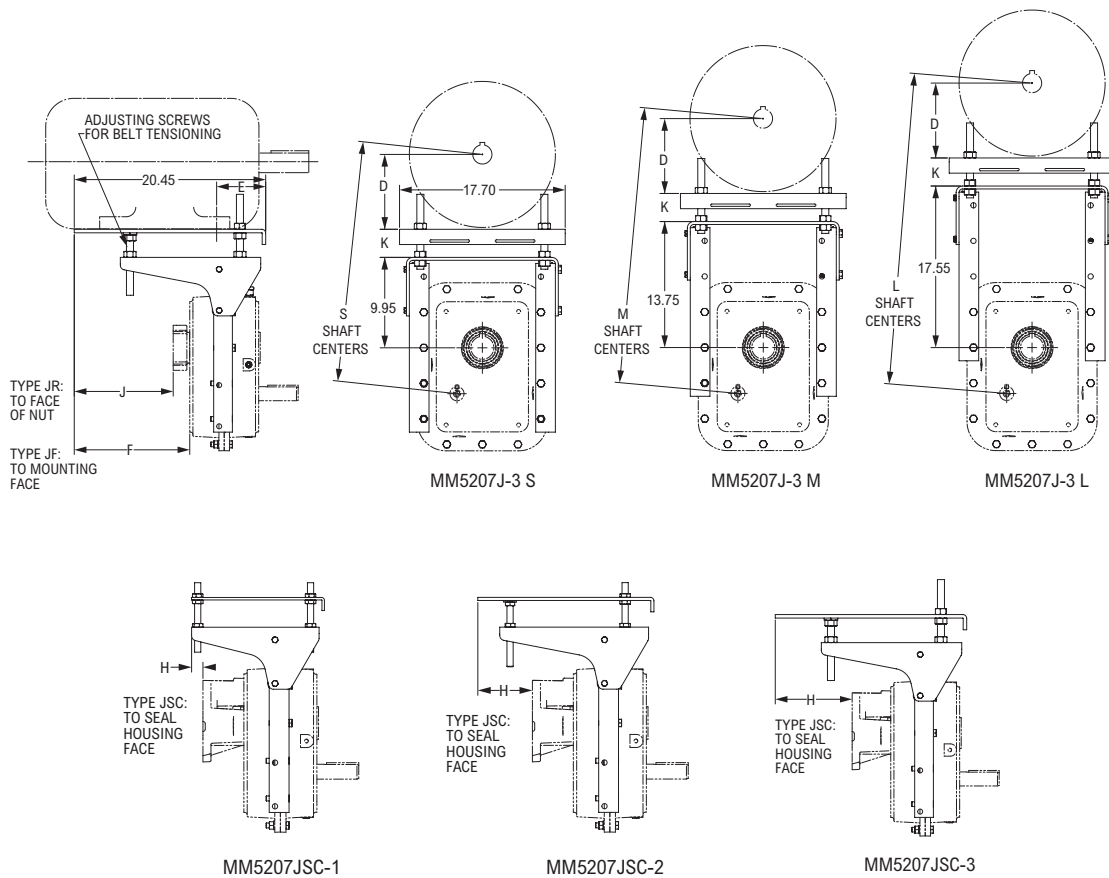

Frame	-1				-2		-3
	56	143-145T	182-184T	213-215T	254-256T	284-286T	324-326T
D	3.50	3.50	4.50	5.25	6.25	7.00	8.00
E	3.04	2.54	2.96	3.74	4.87	5.24	5.74
Shaft Centers	Min-Max	Min-Max	Min-Max	Min-Max	Min-Max	Min-Max	Min-Max
(S) Short	19.9 23.8	19.9 23.8	20.9 24.8	21.6 25.5	22.9 27.2	23.7 28.0	25.0 28.8
(M) Medium	23.7 27.6	23.7 27.6	24.7 28.6	25.4 29.3	26.7 31.0	27.5 31.8	28.8 32.6
(L) Long	27.4 31.4	27.4 31.4	28.4 32.4	29.2 33.1	30.5 34.8	31.2 35.6	32.6 36.4

### Dimensions (in)

Motor Mount Size ⑧	Part Number	Type T Frame ⑩		F	H	J	K		U			Motor Mount Wt (lb)
		Min	Max				Min	Max	Short	Med	Long	
MM5207J-1 SML	7708127	56	215	5.27	1.14	3.50	1.37	5.25	6.96	10.76	14.56	43.7
MM5207J-2 SML	7708128	254	286	9.63	5.50	7.86	1.68	6.00	6.91	10.71	14.51	59.5
MM5207J-3 SML	7708129	324	326	12.34	8.21	10.57	1.91	5.25	6.91	10.71	14.51	81.2

- ① Dimensions are for reference only and are subject to change without notice unless certified.
- ② Hexagon head screws with UNC thread are furnished by Regal Rexnord for mounting the gear drive to the trough end.
- ③ Shaft diameters under 3" are held to limits of +.000", -.002". Shaft diameters 3" and over are held to limits of +.000", -.003".
- ④ See page 49 for optional 316 stainless steel driveshafts – stocked.
- ⑤ Check driveshaft torque & bending capacity and coupling bolt shear & bearing stresses against load to be transmitted. See above drawing for location of third driveshaft-coupling bolt hole if required.
- ⑥ Non-CEMA\* standard dimension.
- ⑦ 24" screw diameter is not compatible with the standard motor mount.
- ⑧ Dimensions are for reference only and are subject to change without notice unless certified. When determining belt length for minimum shaft centers, follow the belt manufacturer's installation allowance recommendations.
- ⑨ Refer to Manual 377-820 for standard vertical assemblies and all Type U frame motor limits.
- ⑩ Refer to Factory for alternate drive assembly dimensions.

\*CEMA is believed to be the trademark and/or trade name of Conveyor Equipment Manufacturers Association Inc. and is not owned or controlled by Regal Rexnord Corporation.

# Size 5215 Shaft-Mounted (JR) & Flange-Mounted (JF) Drive

## Dimensions (in) <sup>①</sup>

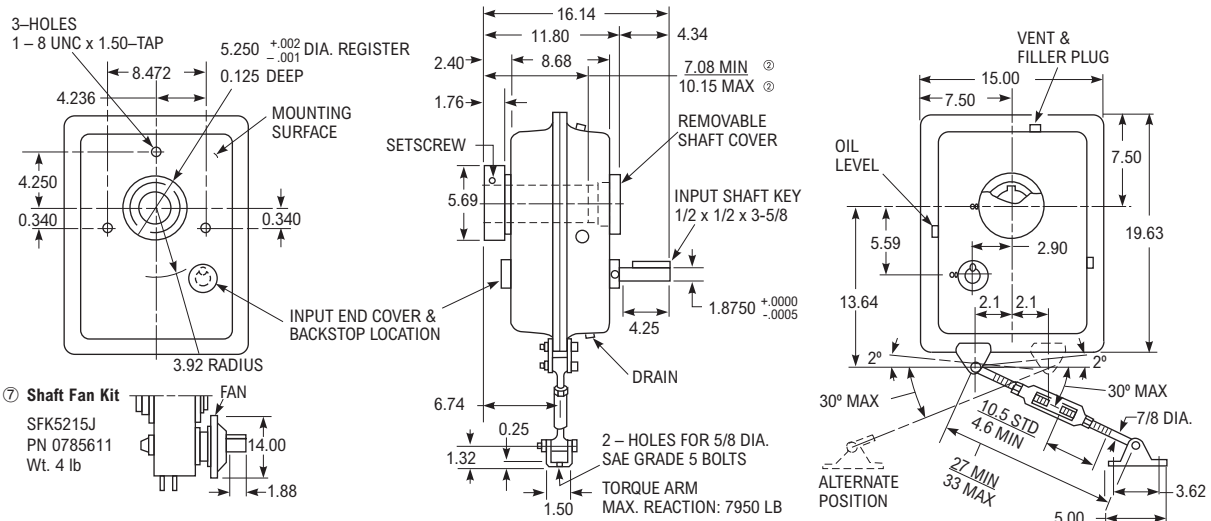

## Hollow Shaft Details

See Manual 377-140 for JF drive tapered driven shaft recommendations. See Manual 377-142 for JF drives using tapered bushings.

## Angular Limits for Horizontal Mounting

(All Clock Positions)

Refer to Factory for lubrication analysis of all inclined drives exceeding the maximum specified below. Also for drives with combined incline down and rotation.

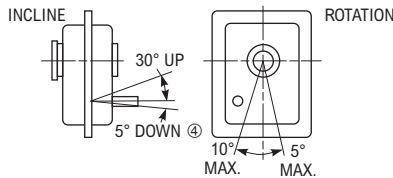

Basic Drive Size <sup>③</sup>	Part Number	Exact Ratio	Max Output RPM	Wt (lb)
5215J05A	0794382	4.923	350	245
5215J09A	0794383	8.997	190	260
5215J14A	0794384	13.60	125	260
5215J25A	0794385	24.94	70	260

## TA Taper Bushings

### Style No. 1 — Thin-wall bushing

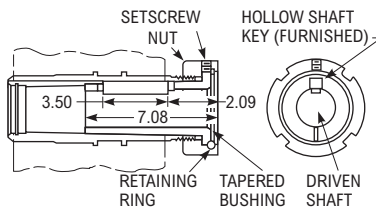

### Style No. 2 — Thick-wall bushing

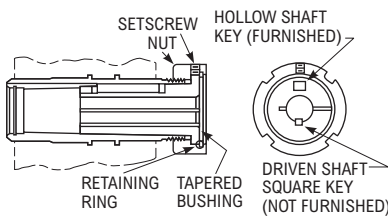

Bushing Size	Part Number <sup>⑤</sup>	Style No.	Driven Shaft Keyway/Min Key Length <sup>⑥</sup>	Wt (lb)
BU5215J-1.938	0769137	2	1/2 x 1/4 x 5	11.4
BU5215J-2.000	0769138	2	1/2 x 1/4 x 4-3/4	11.1
BU5215J-2.188	0769139	2	1/2 x 1/4 x 4-1/2	9.9
BU5215J-2.250	0769140	2	1/2 x 1/4 x 4-1/4	9.5
BU5215J-2.438	0769141	1	5/8 x 5/16 x 3-1/2	8.3
BU5215J-2.500	0769142	1	5/8 x 5/16 x 3-1/2	7.8
BU5215J-2.688	0769143	1	5/8 x 5/16 x 3-1/2	6.5
BU5215J-2.750	2116065	1	5/8 x 5/16 x 3-1/2	5.5
BU5215J-2.938	0769144	1	3/4 x 3/8 x 3-1/2	4.5

## Accessories

### Torque Arm

TA5215J  
PN 0785267  
Wt. 10 lb

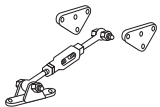

### Backstop

BS5215J05/09/14/25  
PN 0785610  
Wt. 3 lb



### Thrust Plate Kit

TP5215J  
PN 0769136  
Wt. 2 lb



- ① Dimensions are for reference only and are subject to change without notice unless certified.
- ② MIN = Minimum required projection of driven shaft. MAX = Maximum projection of driven shaft which allows for use of thrust plate.
- ③ JR = Basic Drive + Bushing + Torque Arm  
JF = Basic Drive (Bushing Optional)  
JSC = Basic Drive + Seal Housing + Driveshaft
- ④ 0° incline down on drives with backstops in 9 or 12 o'clock mounting.
- ⑤ Consists of bushing, drive key, nut, retaining ring and setscrew.
- ⑥ Check strength of driven shaft and unfurnished key.
- ⑦ See Page 52 for part numbers to order a Shaft Fan Kit with a Belt Guard.



**Size 5215 Screw Conveyor (JSC) Drive** (continued)

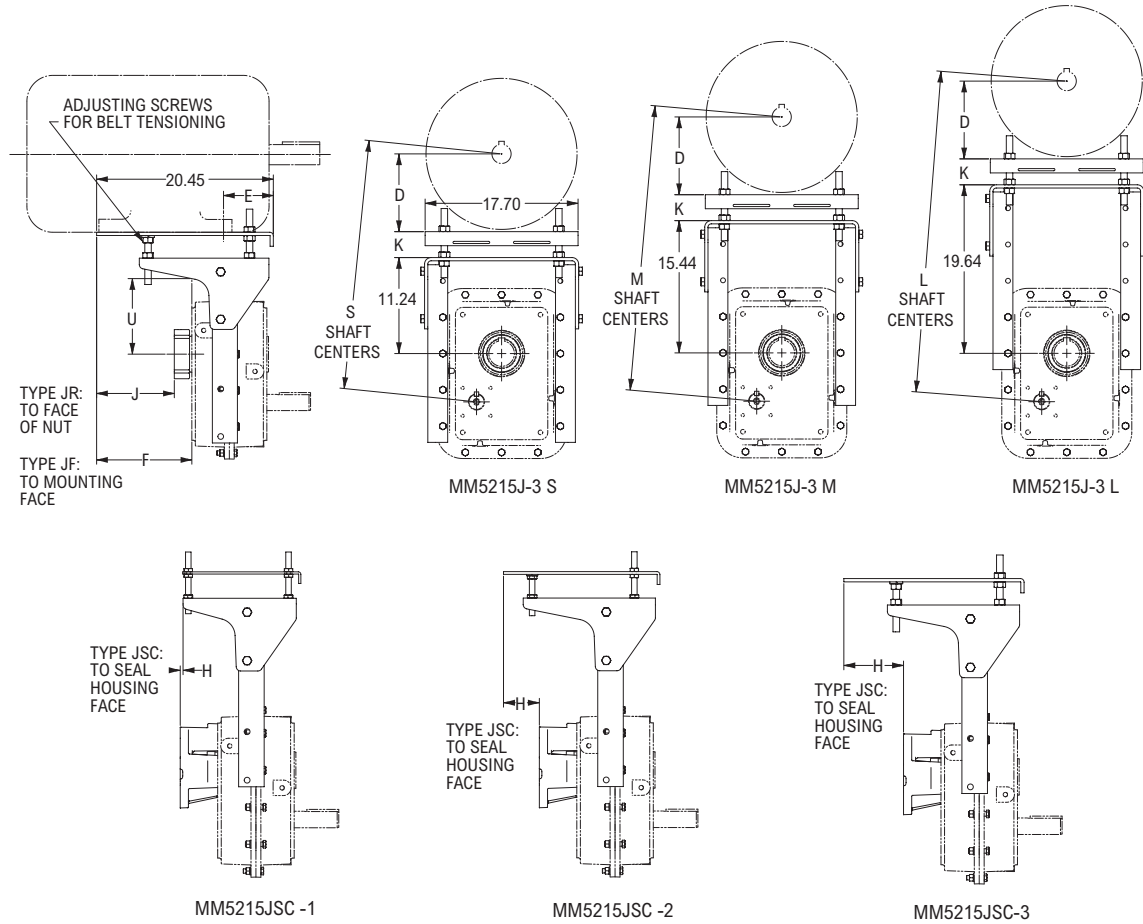

Frame ⑥	-1						-2				-3					
	56		143-145T		182-184T		213-215T		254-256T		284-286T		324-326T		364-365T	
D	3.50		3.50		4.50		5.25		6.25		7.00		8.00		9.00	
E	3.04		2.54		2.96		3.74		4.87		5.24		5.74		6.37	
Shaft Centers	Min-Max		Min-Max		Min-Max		Min-Max		Min-Max		Min-Max		Min-Max		Min-Max	
(S) Short	21.9	25.8	21.9	25.8	22.9	26.8	23.6	27.5	24.9	29.2	25.7	30.0	27.0	30.7	28.0	31.7
(M) Medium	26.0	29.9	26.0	29.9	27.0	30.9	27.8	31.7	29.1	33.4	29.9	34.2	31.2	34.9	32.2	35.9
(L) Long	30.2	34.1	30.2	34.1	31.2	35.1	32.0	35.9	33.3	37.6	34.0	38.4	35.3	39.1	36.3	40.1

**Dimensions (in)**

Motor Mount Size ⑥	Part Number	Type T Frame ⑦		F	H	J	K		U			Motor Mount Wt (lb)
		Min	Max				Min	Max	Short	Med	Long	
MM5215J-1 SML	7708130	56	215	3.93	0.32	1.90	1.37	5.25	8.88	13.08	17.28	56.1
MM5215J-2 SML	7708131	254	286	8.32	4.07	6.29	1.68	6.00	8.27	12.47	16.67	83.9
MM5215J-3 SML	7708132	324	365	11.02	6.77	8.99	1.91	5.25	8.27	12.47	16.67	101.1

- ① Dimensions are for reference only and are subject to change without notice unless certified.
- ② Hexagon head screws with UNC thread are furnished by Regal Rexnord for mounting the gear drive to the trough end.
- ③ Shaft diameters under 3" are held to limits of +.000", -.002". Shaft diameters 3" and over are held to limits of +.000", -.003".
- ④ See page 49 for optional 316 stainless steel driveshafts – stocked.
- ⑤ Check driveshaft torque & bending capacity and coupling bolt shear & bearing stresses against load to be transmitted. See above drawing for location of third driveshaft-coupling bolt hole if required.
- ⑥ Dimensions are for reference only and are subject to change without notice unless certified. When determining belt length for minimum shaft centers, follow the belt manufacturer's installation allowance recommendations.
- ⑦ Refer to Manual 377-820 for standard vertical assemblies and all Type U frame motor limits.
- ⑧ Refer to Factory for alternate drive assembly dimensions.
- ⑨ Shaft-driven fans are not compatible with motor mounts for frames 56 thru 215T.

# Size 5307 Shaft-Mounted (JR) & Flange-Mounted (JF) Drive

## Dimensions (in) <sup>①</sup>

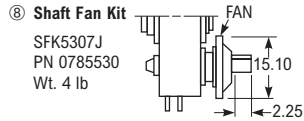
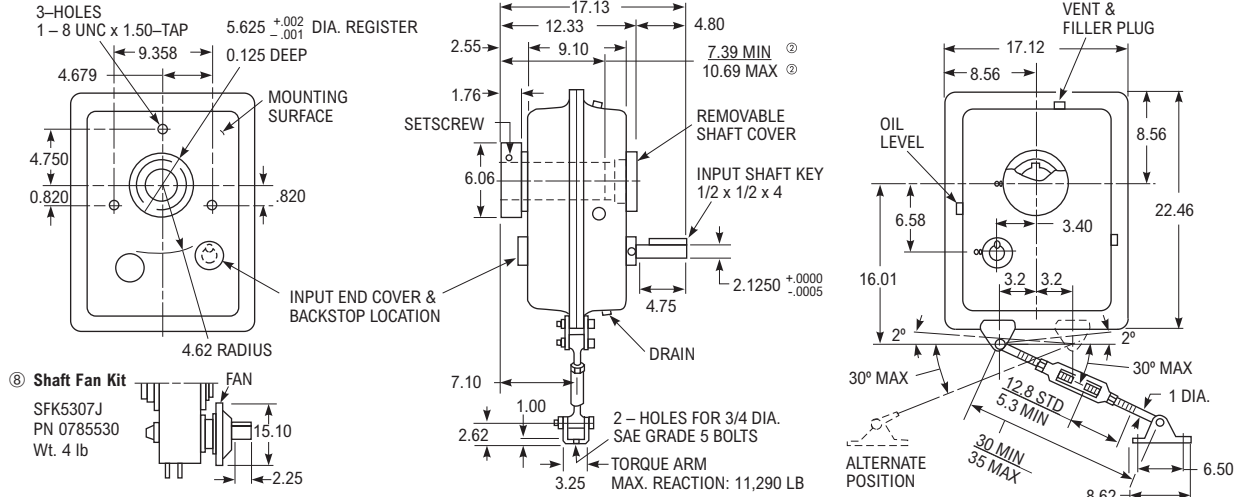

## Hollow Shaft Details

See Manual 377-140 for JF drive tapered driven shaft recommendations. See Manual 377-142 for JF drives using tapered bushings.

## Angular Limits for Horizontal Mounting

(All Clock Positions)

Refer to Factory for lubrication analysis of all inclined drives exceeding the maximum specified below. Also for drives with combined incline down and rotation.

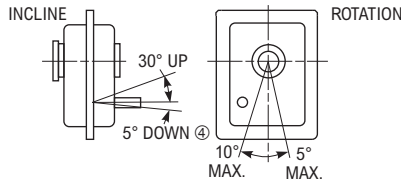

Basic Drive Size <sup>③</sup>	Part Number	Exact Ratio	Max Output RPM	Wt (lb)
5307J05A	0794386	4.857	350	355
5307J09A	0794387	9.131	190	375
5307J14A	0794388	14.03	125	375
5307J25A	0794389	25.26	70	375

## TA Taper Bushings

### Style No. 1 — Thin-wall bushing

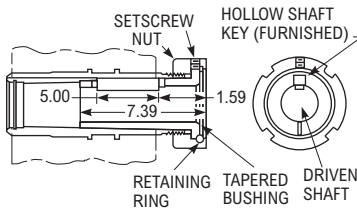

### Style No. 2 — Thick-wall bushing

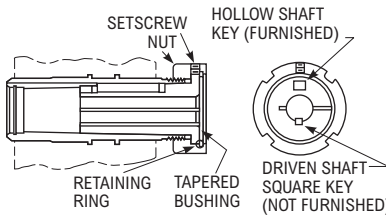

Bushing Size	Part Number <sup>⑤</sup>	Style No.	Driven Shaft Keyway/Min Key Length <sup>⑥</sup>	Wt (lb)
BU5307J-2.000	0769155	2	1/2 x 1/4 x 7	17.8
BU5307J-2.188	0769156	2	1/2 x 1/4 x 7	16.6
BU5307J-2.250	0769157	2	1/2 x 1/4 x 7	16.2
BU5307J-2.438	0769158	2	5/8 x 5/16 x 5-1/2	14.9
BU5307J-2.500	0769159	2	5/8 x 5/16 x 5	14.4
BU5307J-2.688	0769160	1	5/8 x 5/16 x 5	13.0
BU5307J-2.938	0769161	1	3/4 x 3/8 x 5	10.9
BU5307J-3.000	0769162	1	3/4 x 3/8 x 5	10.3
BU5307J-3.188	0769163	1	3/4 x 3/8 x 5	8.6
BU5307J-3.438	0769164	1	7/8 x 7/16 x 5	6.1

## Accessories

### Torque Arm

TA5307J  
PN 0785269  
Wt. 25 lb

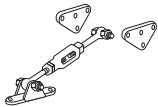

### Backstop <sup>⑦</sup>

BS5307J09/14/25  
PN 0785529  
Wt. 3 lb



### Thrust Plate Kit

TP53075J  
PN 0769154  
Wt. 3 lb



- ① Dimensions are for reference only and are subject to change without notice unless certified.
- ② MIN = Minimum required projection of driven shaft. MAX = Maximum projection of driven shaft which allows for use of thrust plate.
- ③ JR = Basic Drive + Bushing + Torque Arm  
JF = Basic Drive (Bushings Optional)  
JSC = Basic Drive + Seal Housing + Driveshaft
- ④ 0° incline down on drives with backstops in 9 or 12 o'clock mounting.
- ⑤ Consists of bushing, drive key, nut, retaining ring and setscrew.
- ⑥ Check strength of driven shaft and unfurnished key.
- ⑦ Not available in 5:1 ratio.
- ⑧ See Page 52 for part numbers to order a Shaft Fan Kit with a Belt Guard.

# Size 5307 Screw Conveyor (JSC) Drive

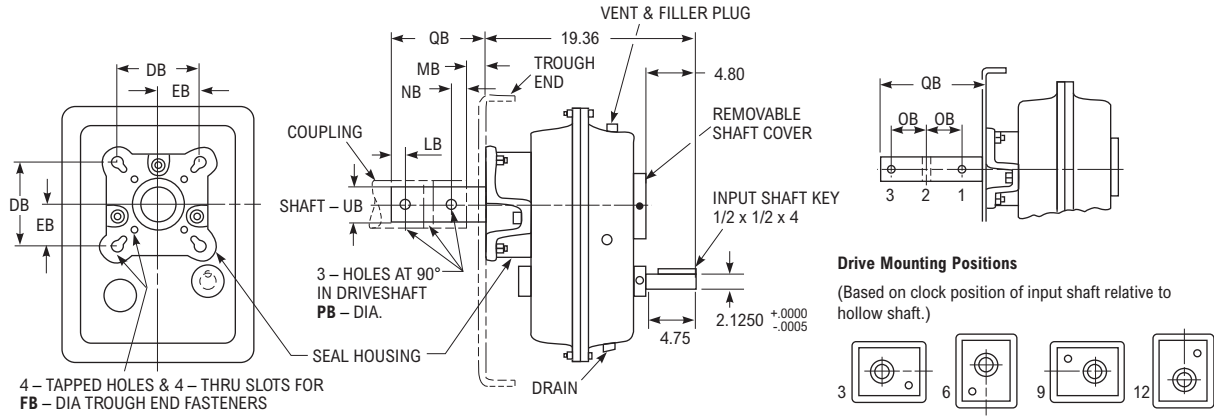

## Dimensions (in) ①

Basic Drive Size ①	Screw Conveyor Components									DB	EB	FB ②	LB	MB	NB	OB	PB	QB	UB ③
	Cplg Dia	Screw Dia	Max Tq (lb-in)	Driveshaft w/Thrust Plane ④	Part No.	Wt (lb)	Seal Housing	Part No.	Wt (lb)										
5307	2.437	12, 14	18,200	DS5307J-2.437 ⑤	6720029	49	SH5307J	0769152	36	5.625	2.812	0.625	0.938	1.812	0.938	3.000	0.656	9.688 ⑥	2.437
	3.000	12-20	34,300	DS5307J-3.000 ⑤	6720030	56	SH5307J	0769152	36	6.000	3.000	0.750	1.000	1.875	1.000	3.000	0.781	9.875 ⑥	3.000
	3.437	18-24	51,400	DS5307J-3.437 ⑤	6720031	70	SH5307J	0769152	36	6.750	3.375	0.750	1.250	2.375	1.500	4.000	0.906	13.125 ⑥	3.437

## Trough End Seals

Lip Seal  
 PN 0912741  
 Wt. 1 lb

Packing Gland Seal Kit  
 PGSK5307J  
 PN 0738466  
 Wt. 1 lb

## Motor Mounts

Standard Horizontal Drive Assembly – (6 o'clock shown) (3-9-12 o'clock optional with limitations, see note 8.)

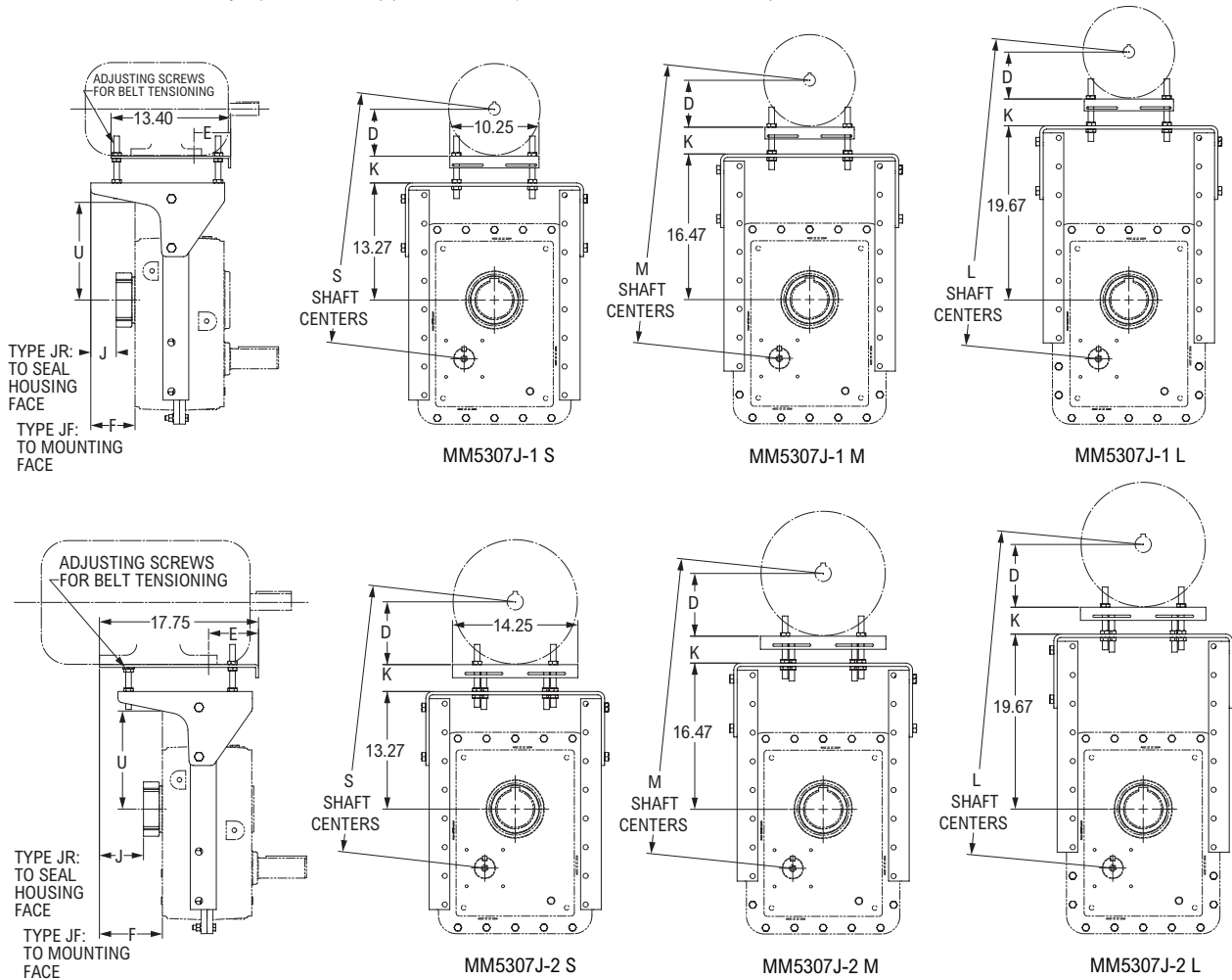

# Size 5307 Screw Conveyor (JSC) Drive (continued)

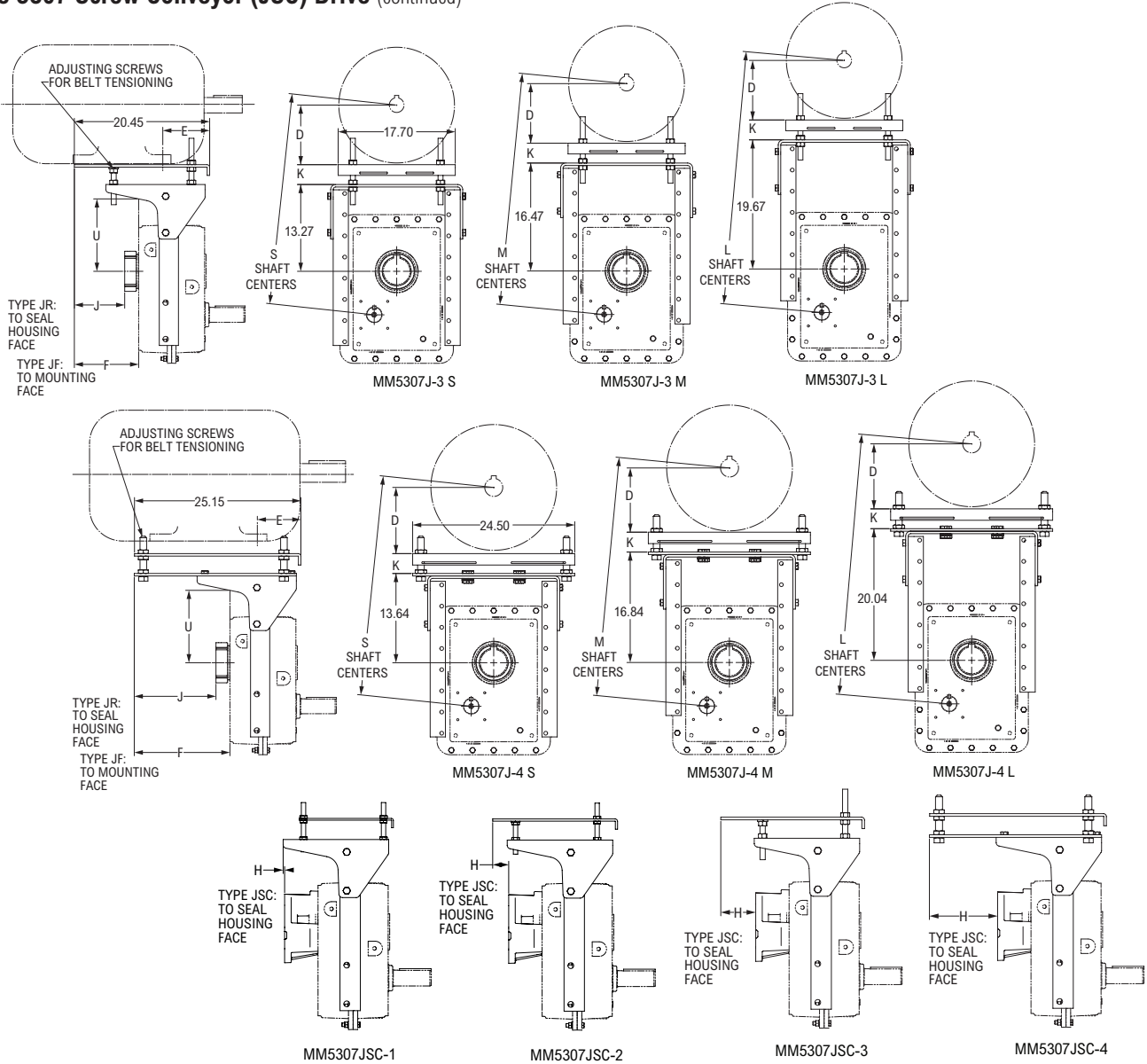

	-1				-2				-3				-4		
Frame ⑨	56	143-145T	182-184T	213-215T	254-256T	284-286T	324-326T	364-365T	404T						
D	3.50	3.50	4.50	5.25	6.25	7.00	8.00	9.00	10.00						
E	3.04	2.54	2.96	3.74	4.87	5.24	5.74	6.37	7.12						
Shaft Centers	Min-Max	Min-Max	Min-Max	Min-Max	Min-Max	Min-Max	Min-Max	Min-Max	Min-Max						
(S) Short	25.0 28.9	25.0 28.9	26.0 29.9	26.8 30.7	28.0 32.3	28.7 33.0	30.0 33.7	31.0 34.7	32.6 35.0						
(M) Medium	28.2 32.1	28.2 32.1	29.2 33.1	30.0 33.9	31.2 35.5	31.9 36.2	33.2 36.9	34.2 37.9	35.8 38.2						
(L) Long	31.4 35.3	31.4 35.3	32.4 36.3	33.1 37.1	34.3 38.7	35.1 39.4	36.4 40.1	37.4 41.1	39.0 41.4						

## Dimensions (in)

Motor Mount Size ⑥	Part Number	Type T Frame ⑦		F	H	J	K		U			Motor Mount Wt (lb)
		Min	Max				Min	Max	Short	Med	Long	
MM5307J-1 SML	7708133	56	215	5.39	0.64	3.28	1.37	5.25	10.40	13.60	16.80	77.2
MM5307J-2 SML	7708134	254	286	7.90	3.15	5.79	1.68	6.00	10.40	13.60	16.80	84.8
MM5307J-3 SML	7708135	324	365	10.60	5.85	8.49	1.96	5.90	10.40	13.60	16.80	106.7
MM5307J-4 SML	7708136	404	405	15.34	10.59	13.23	2.15	4.85	10.40	13.60	16.80	204.4

- ① Dimensions are for reference only and are subject to change without notice unless certified.
- ② Hexagon head screws with UNC thread are furnished by Regal Rexnord for mounting the gear drive to the trough end.
- ③ Shaft diameters under 3" are held to limits of +.000", -.002". Shaft diameters 3" and over are held to limits of +.000", -.003".
- ④ See page 49 for optional 316 stainless steel driveshafts – stocked.
- ⑤ Check driveshaft torque & bending capacity and coupling bolt shear & bearing stresses against load to be transmitted. See above drawing for location of third driveshaft-coupling bolt hole if required.
- ⑥ Dimensions are for reference only and are subject to change without notice unless certified. When determining belt length for minimum shaft centers, follow the belt manufacturer's installation allowance recommendations.
- ⑦ Refer to Manual 377-820 for standard vertical assemblies and all Type U frame motor limits.
- ⑧ Refer to Factory for alternate drive assembly dimensions.
- ⑨ Shaft-driven fans are not compatible with motor mounts for frames 56 thru 215T.

# Size 5315 Shaft-Mounted (JR) & Flange-Mounted (JF) Drive

## Dimensions (in) <sup>①</sup>

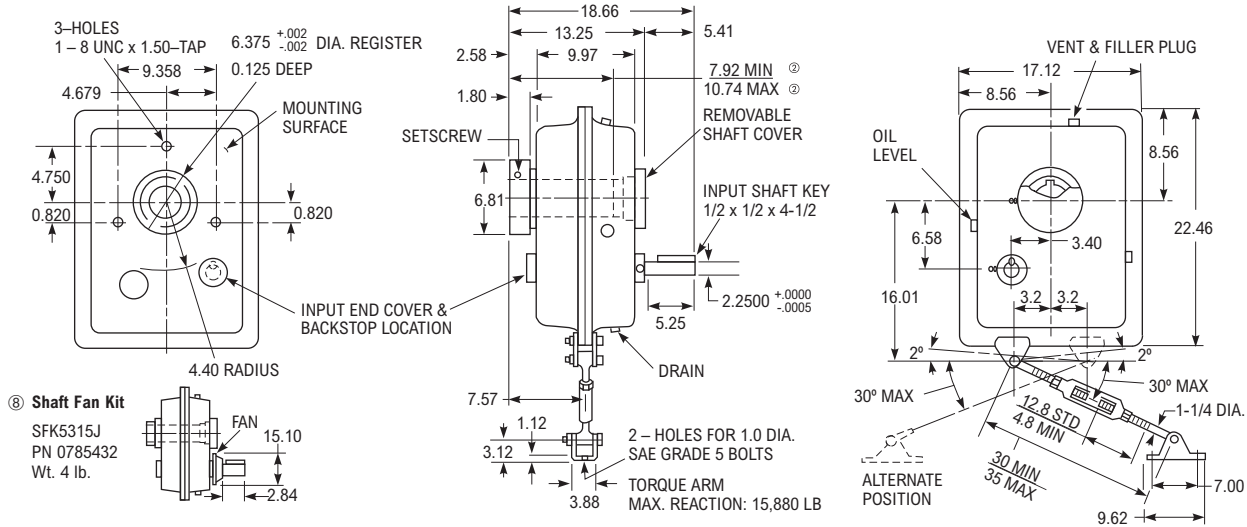

## Hollow Shaft Details

See Manual 377-140 for JF drive tapered driven shaft recommendations. See Manual 377-142 for JF drives using tapered bushings.

## Angular Limits for Horizontal Mounting

(All Clock Positions)

Refer to Factory for lubrication analysis of all inclined drives exceeding the maximum specified below. Also for drives with combined incline down and rotation.

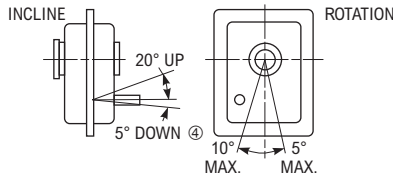

Basic Drive Size <sup>③</sup>	Part Number	Exact Ratio	Max Output RPM	Wt (lb)
5315J05A	0794390	4.857	350	375
5315J09A	0794391	9.131	190	400
5315J14A	0794392	13.91	125	400
5315J25A	0794393	25.26	70	400

## TA Taper Bushings

### Style No. 1 — Thin-wall bushing

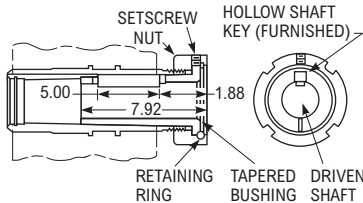

### Style No. 2 — Thick-wall bushing

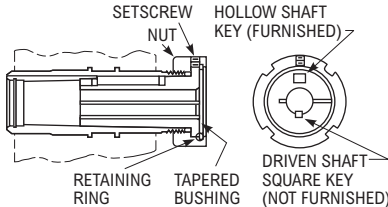

Bushing Size	Part Number <sup>⑤</sup>	Style No.	Driven Shaft Keyway/Min Key Length <sup>⑥</sup>	Wt (lb)
BU5315J-2.438	0785778	2	5/8 x 5/16 x 7-1/2	23.6
BU5315J-2.500	0785779	2	5/8 x 5/16 x 7-1/2	23.1
BU5315J-2.688	0785780	2	5/8 x 5/16 x 7-1/2	21.6
BU5315J-2.938	0785781	2	3/4 x 3/8 x 5-1/2	19.4
BU5315J-3.000	0785782	2	3/4 x 3/8 x 5-1/2	18.8
BU5315J-3.438	0785783	1	7/8 x 7/16 x 5	14.3
BU5315J-3.938	0785784	1	1 x 1/2 x 5	8.4

## Accessories

### Torque Arm

TA5315J  
PN 0785270  
Wt. 38 lb

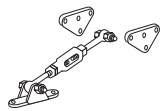

### Backstop <sup>⑦</sup>

BS5315J09/14/25  
PN 0757183  
Wt. 7 lb



### Thrust Plate Kit

TP5315J  
PN 0769207  
Wt. 4 lb



- ① Dimensions are for reference only and are subject to change without notice unless certified.
- ② MIN = Minimum required projection of driven shaft. MAX = Maximum projection of driven shaft which allows for use of thrust plate.
- ③ JR = Basic Drive + Bushing + Torque Arm  
JF = Basic Drive (Bushings Optional)  
JSC = Basic Drive + Seal Housing + Driveshaft
- ④ 0° incline down on drives with backstops in 9 or 12 o'clock mounting.
- ⑤ Consists of bushing, drive key, nut, retaining ring and setscrew.
- ⑥ Check strength of driven shaft and unfurnished key.
- ⑦ Not available in 5:1 ratio.
- ⑧ See Page 52 for part numbers to order a Shaft Fan Kit with a Belt Guard.

# Size 5315 Screw Conveyor (JSC) Drive

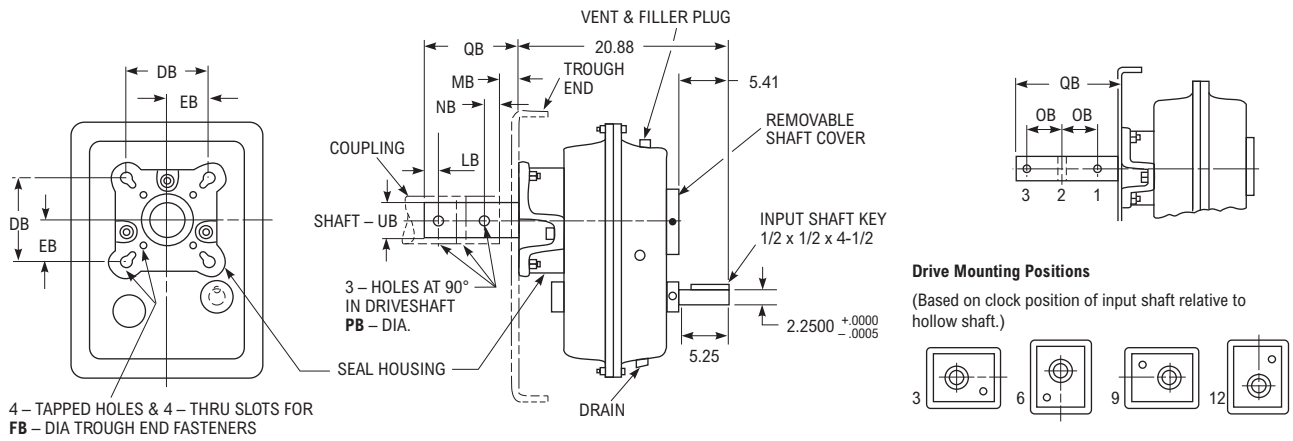

## Dimensions (in) ①

Basic Drive Size ①	Screw Conveyor Components										DB	EB	FB ②	LB	MB	NB	OB	PB	QB	UB ③
	Cplg Dia	Screw Dia	Max Tq (lb-in)	Driveshaft w/Thrust Plane ④	Part No.	Wt (lb)	Seal Housing	Part No.	Wt (lb)	Part No.										
5315	2.437	12, 14	18,220	DS5315J-2.437 ⑤	6720032	58	SH5315J	0769206	36	5.625	2.812	0.625	0.938	1.812	0.938	3.000	0.656	9.688 ⑤	2.437	
	3.000	12-20	34,300	DS5315J-3.000 ⑤	6720033	65	SH5315J	0769206	36	6.000	3.000	0.750	1.000	1.875	1.000	3.000	0.781	9.875 ⑤	3.000	
	3.438	18-24	51,400	DS5315J-3.437 ⑤	6720034	80	SH5315J	0769206	36	6.750	3.375	0.750	1.250	2.375	1.500	4.000	0.906	13.125 ⑤	3.437	

## Trough End Seals

Lip Seal

PN 0912741

Wt. 1 lb

Packing Gland Seal Kit

PGSK5315J

PN 0738466

Wt. 1 lb

## Motor Mounts

Standard Horizontal Drive Assembly – (6 o'clock shown) (3-9-12 o'clock optional with limitations, see note 8.)

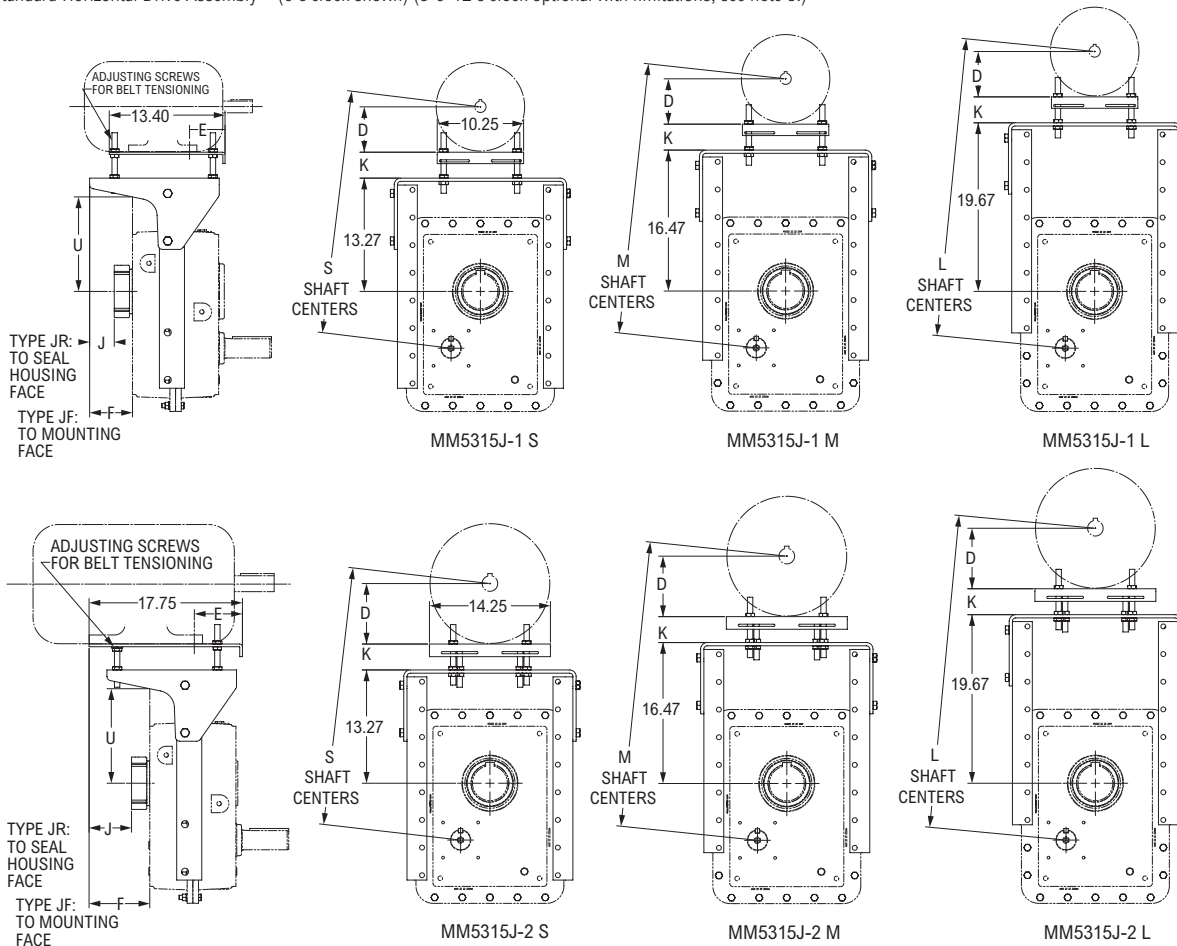

## Size 5315 Screw Conveyor (JSC) Drive (continued)

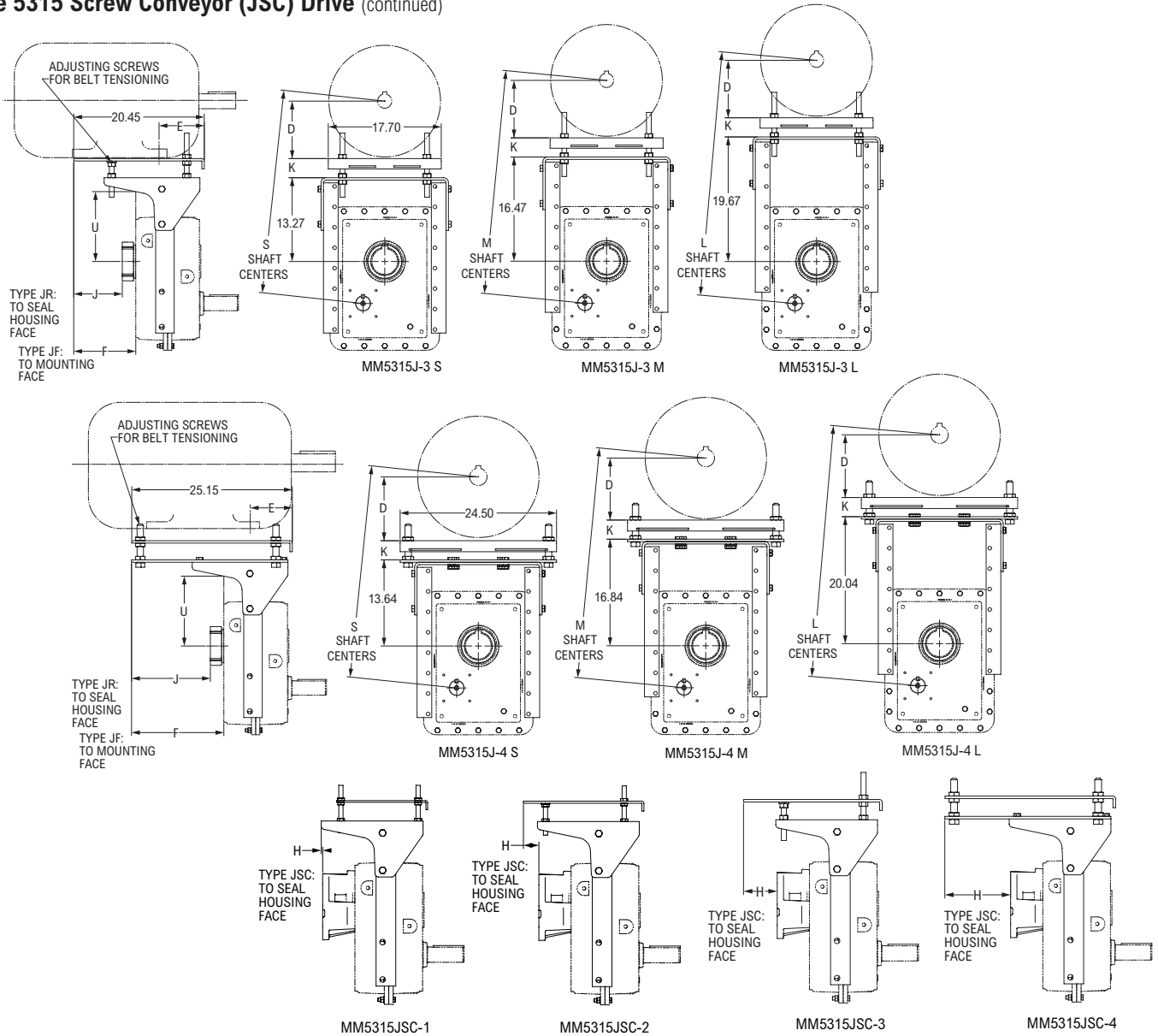

	-1				-2				-3				-4					
Frame ⑥	56	143-145T	182-184T	213-215T	254-256T	284-286T	324-326T	364-365T	404T									
D	3.50	3.50	4.50	5.25	6.25	7.00	8.00	9.00	10.00									
E	3.04	2.54	2.96	3.74	4.87	5.24	5.74	6.37	7.12									
Shaft Centers	Min-Max		Min-Max		Min-Max		Min-Max		Min-Max		Min-Max		Min-Max					
(S) Short	25.0	28.9	25.0	28.9	26.0	29.9	26.8	30.7	28.0	32.3	28.7	33.0	30.0	33.7	31.0	34.7	32.6	35.0
(M) Medium	28.2	32.1	28.2	32.1	29.2	33.1	30.0	33.9	31.2	35.5	31.9	36.2	33.2	36.9	34.2	37.9	35.8	38.2
(L) Long	31.4	35.3	31.4	35.3	32.4	36.3	33.1	37.1	34.3	38.7	35.1	39.4	36.4	40.1	37.4	41.1	39.0	41.4

Motor Mount Size ⑧	Part Number	Type T Frame ⑦		F	H	J	K		U			Motor Mount Wt (lb)
		Min	Max				Min	Max	Short	Med	Long	
MM5315J-1 SML	7708133	56	215	4.96	0.21	2.85	1.37	5.25	10.49	13.69	16.89	77.2
MM5315J-2 SML	7708134	254	286	7.03	2.28	4.92	1.68	6.00	10.49	13.69	16.89	84.8
MM5315J-3 SML	7708135	324	365	9.72	4.97	7.61	1.96	5.90	10.49	13.69	16.89	106.7
MM5315J-4 SML	7708136	404	405	14.46	9.71	12.35	2.15	4.85	10.49	13.69	16.89	204.4

### Dimensions (in)

- ① Dimensions are for reference only and are subject to change without notice unless certified.
- ② Hexagon head screws with UNC thread are furnished by Regal Rexnord for mounting the gear drive to the trough end.
- ③ Shaft diameters under 3" are held to limits of +.000", -.002". Shaft diameters 3" and over are held to limits of +.000", -.003".
- ④ See page 49 for optional 316 stainless steel driveshafts – stocked.
- ⑤ Check driveshaft torque & bending capacity and coupling bolt shear & bearing stresses against load to be transmitted. See above drawing for location of third driveshaft-coupling bolt hole if required.
- ⑥ Dimensions are for reference only and are subject to change without notice unless certified. When determining belt length for minimum shaft centers, follow the belt manufacturer's installation allowance recommendations.
- ⑦ Refer to Manual 377-820 for standard vertical assemblies and all Type U frame motor limits.
- ⑧ Refer to Factory for alternate drive assembly dimensions.
- ⑨ Shaft-driven fans are not compatible with motor mounts for frames 56 thru 215T.

# Size 5407 Shaft-Mounted (JR) Drive

## Dimensions (in) <sup>①</sup>

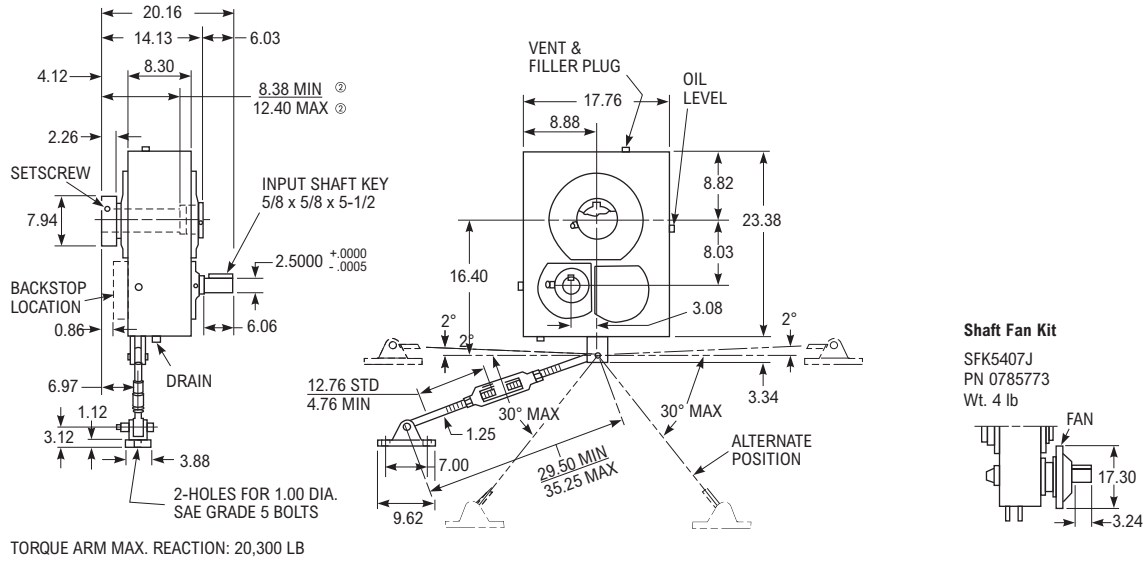

## Hollow Shaft Details

See Manual 377-140 for JF drive tapered driven shaft recommendations. See Manual 377-144 for JF drives using tapered bushings.

## Angular Limits for Horizontal Mounting

(All Clock Positions)

Refer to Factory for lubrication analysis of all inclined drives exceeding the maximum specified below.

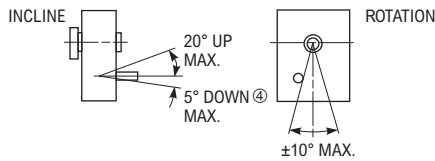

Basic Drive Size <sup>③</sup>	Part Number	Exact Ratio	Max Output RPM	Wt (lb)
5407J05A	0794400	4.938	350	575
5407J14A	0794401	13.89	125	606
5407J25A	0794402	25.04	70	606

## TA Taper Bushings

### Style No. 1 — Thin-wall bushing

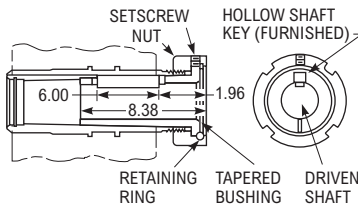

### Style No. 2 — Thick-wall bushing

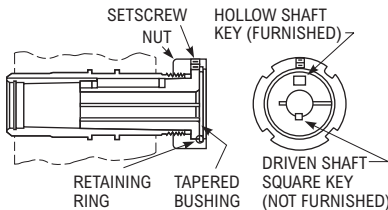

Bushing Size	Part Number <sup>⑤</sup>	Style No.	Driven Shaft Keyway/Min Key Length <sup>⑥</sup>	Wt (lb)
BU5407J-2.938	0786822	2	3/4 x 3/8 x 7-1/2	29.7
BU5407J-3.438	0785774	1	7/8 x 7/16 x 6	24.0
BU5407J-3.938	0785775	1	1 x 1/2 x 6	17.3
BU5407J-4.188	0785776	1	1 x 1/2 x 6	13.6
BU5407J-4.438	0785777	1	1 x 1/2 x 6	11.4

- ① Dimensions are for reference only and are subject to change without notice unless certified.
- ② MIN = Minimum required projection of driven shaft. MAX = Maximum projection of driven shaft which allows for use of thrust plate.
- ③ JR = Basic Drive + Bushing + Torque Arm  
JF = Basic Drive (Bushings Optional)  
JSC = Basic Drive + Seal Housing + Driveshaft
- ④ 0° incline down on drives with backstops in 9 or 12 o'clock mounting.
- ⑤ Consists of bushing, drive key, nut, retaining ring and setscrew.
- ⑥ Check strength of driven shaft and unfurnished key.

# Size 5407 Flange-Mounted (JF) Drive

## Dimensions (in) <sup>①</sup>

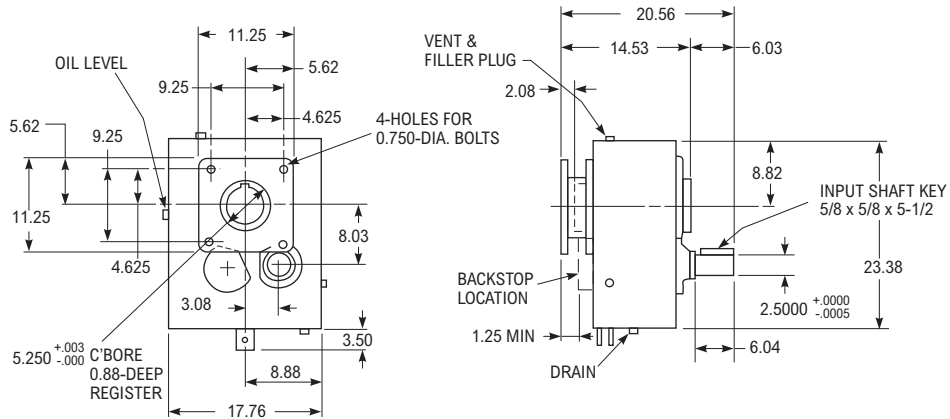

## Drive Mounting Positions

(Based on clock position of input shaft relative to hollow shaft.)

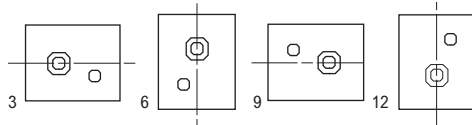

Drive Size <sup>②</sup>	Part Number	Exact Ratio	Max Output RPM	Wt (lb)
5407JF05A	0794394	4.938	350	540
5407JF14A	0794395	13.89	125	610
5407JF25A	0794396	25.04	70	610

## Hollow Shaft Details

See Manual [377-140](#) for JF drive tapered driven shaft recommendations. See Manual [377-142](#) for JF drives using tapered bushings.

## Angular Limits For Horizontal Mounting

(All Clock Positions)

Refer to Factory for lubrication analysis of all inclined drives exceeding the maximum specified below.

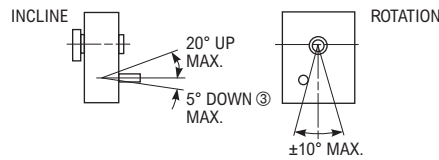

## Accessories

Torque Arm

TA5407J  
PN 0785271  
Wt. 35 lb

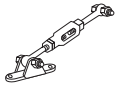

Backstop <sup>④</sup>

BS5407J09/14/25  
PN 0769170  
Wt. 23 lb



Thrust Plate Kit

TP5407J  
PN 0769176  
Wt. 5 lb



- ① Dimensions are for reference only and are subject to change without notice unless certified.
- ② JF = Drive (Includes Output Flange) (Bushing Optional).
- ③ 0° incline down on drives with backstops in 9 or 12 o'clock mounting.
- ④ Not available in 5:1 ratio.

# Size 5407 Screw Conveyor (JSC) Drive

## Dimensions (in) <sup>①</sup>

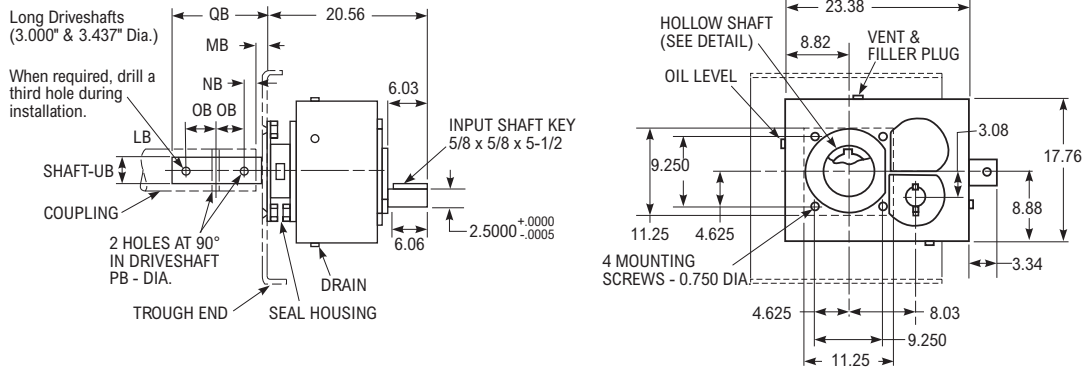

## Angular Limits for Horizontal Mounting

(All Clock Positions)

Refer to Factory for lubrication analysis of all inclined drives exceeding the maximum specified below.

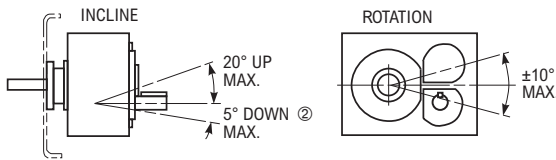

Drive Size <sup>③</sup>	Part Number	Exact Ratio	Max Output RPM	Wt (lb)
5407JSC05A	0794394	4.938	350	540
5407JSC14A	0794395	13.89	125	610
5407JSC25A	0794396	25.04	70	610

## Dimensions (in)

Drive Size <sup>①</sup>	Screw Conveyor Components										MB	NB	OB	PB	QB	UB <sup>⑥</sup>
	Cplg Dia	Screw Dia	Max Tq (lb-in)	Driveshaft w/Thrust Plane <sup>④</sup>	Part No.	Wt (lb)	Seal Housing Accessory Kit <sup>⑤</sup>	Part No.	Wt (lb)							
5407	3.000	14-20	34,300	DS5407J-3.000 <sup>⑦</sup>	6720035	74	SH5407J	0757205	2.5	1.875	1.000	3.000	0.781	10.00 <sup>⑦</sup>	3.000	
	3.438	16-24	51,400	DS5407J-3.437 <sup>⑦</sup>	6720036	89	SH5407J	0757205	2.5	2.375	1.500	4.000	0.906	13.28 <sup>⑦</sup>	3.437	

## Trough End Seals

Lip Seal  
 PN 2913658  
 Wt. 1 lb

- ① Dimensions are for reference only and are subject to change without notice unless certified.
- ② 0° incline down on drives with backstops in 9 or 12 o'clock mounting.
- ③ JSC = Drive (Includes Seal Housing) + Driveshaft + Seal Housing Accessory Kit.
- ④ See page 49 for optional 316 stainless steel driveshafts – stocked.
- ⑤ Consists of waste packing and trough end gasket.
- ⑥ Shaft diameters under 3" are held to limits of +.000", -.002". Shaft diameters 3" and over are held to limits of +.000", -.003".
- ⑦ Check driveshaft torque & bending capacity and coupling bolt shear & bearing stresses against load to be transmitted. See above drawing for location of third driveshaft-coupling bolt hole if required.

# Size 5407 Motor Mounts

Standard Horizontal Drive Assembly – 3 o'clock (A3)

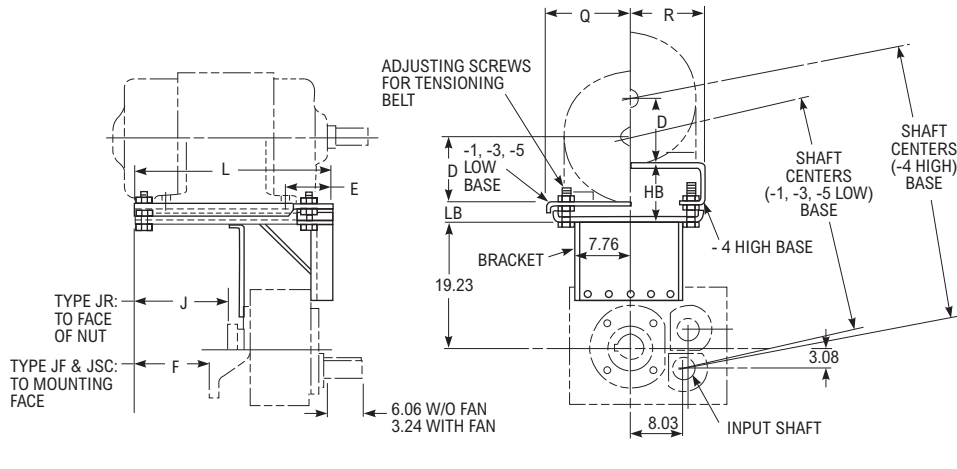

Refer to page 58 for minimum and maximum shaft centers for bottom and side mounting. The assemblies may also be rotated about the hollow shaft in 90° increments to position the input shaft in 3, 6, 9 and 12 o'clock positions, ±10° and mounted vertically.

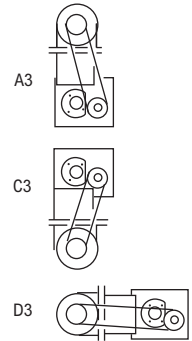

Frame	56	143-145T	182-184T	213-215T	254-256T	284-286T	324-326	364-365T	404-405	444-449T
D	3.50	3.50	4.50	5.25	6.25	7.00	8.00	9.00	10.00	11.00
E	2.68	2.50	2.50	3.25	4.18	4.69	5.19	5.81	6.56	7.45
Shaft Centers ②	Min-Max	Min-Max	Min-Max	Min-Max	Min-Max	Min-Max	Min-Max	Min-Max	Min-Max	Min-Max
-1 Low Base	28.0 - 31.9	28.0 - 31.9	28.9 - 32.9	29.6 - 33.6	—	—	—	—	—	—
-3 Low Base	—	—	—	—	31.4 - 35.1	32.1 - 35.8	33.0 - 36.8	34.0 - 37.7	35.0 - 38.7	—
-4 High Base	—	—	—	—	35.1 - 38.9	35.8 - 39.6	36.8 - 40.6	37.8 - 41.5	38.8 - 42.5	—
-5 Low Base	—	—	—	—	—	—	—	—	—	37.2 - 40.7

## Dimensions (in)

Motor Mount Size ①	Part Number	Type T Frame		F	J	L	Q	R	HB	LB	Motor Mount Wt (lb)
		Min	Max						Min-Max	Min-Max	
MM5407J-1	0757620	56	215	0.18	0.51	15.00	8.16	—	—	1.02-4.84	80
MM5407J-3	0757621	254	405	11.46	11.77	26.26	11.88	—	—	2.12-5.96	193
MM5407J-4	0757622	254	405	11.46	11.77	26.26	—	11.62	6.00-9.84	—	215
MM5407J-5	0786584	444	449	19.20	19.56	34.00	16.00	—	—	3.37-7.00	325

① Dimensions are for reference only and are subject to change without notice unless certified. When determining belt length for minimum shaft centers, follow the belt manufacturer's installation allowance recommendations.

② Shaft centers can be increased up to 1-1/2 inches with shim blocks. See page 59 for shim blocks.

# Size 5415 Shaft-Mounted (JR) Drive

## Dimensions (in) <sup>①</sup>

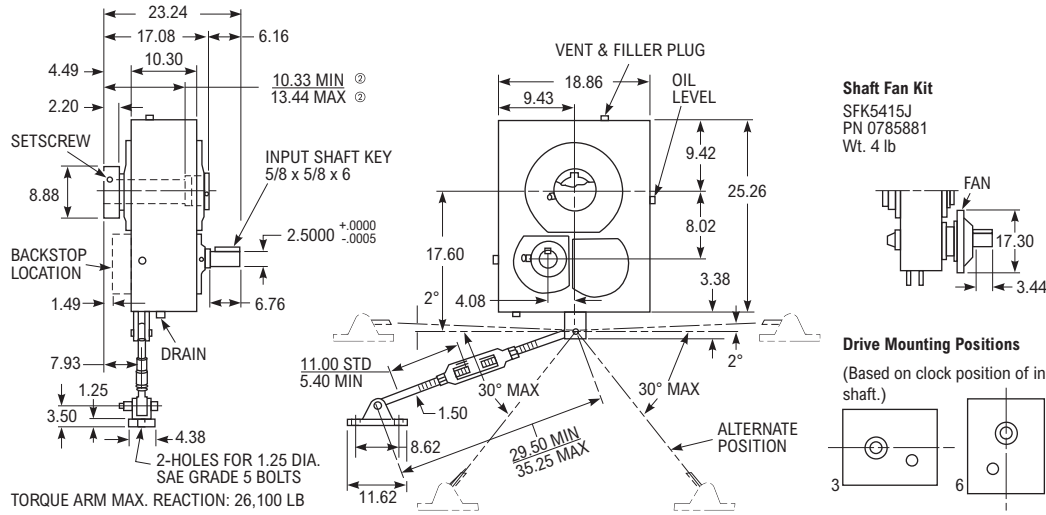

**Shaft Fan Kit**  
SFK5415J  
PN 0785881  
Wt. 4 lb

### Drive Mounting Positions

(Based on clock position of input shaft relative to hollow shaft.)

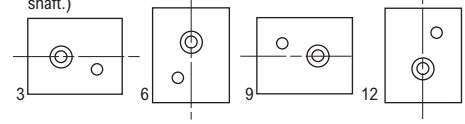

## Hollow Shaft Details

See Manual [377-140](#) for JF drive tapered driven shaft recommendations. See Manual [377-142](#) for JF drives using tapered bushings.

## Angular Limits for Horizontal Mounting

(All Clock Positions)

Refer to Factory for lubrication analysis of all inclined drives exceeding the maximum specified below.

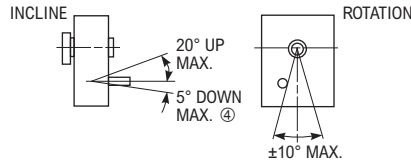

Basic Drive Size <sup>③</sup>	Part Number	Exact Ratio	Max Output RPM	Wt (lb)
5415J05	0794403	5.077	350	765
5415J14A	0794404	13.61	125	795
5415J25A	0794405	26.11	70	795

## TA Taper Bushings

### Style No. 1 — Thin-wall bushing

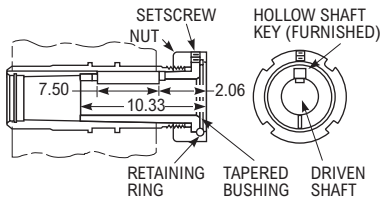

### Style No. 2 — Thick-wall bushing

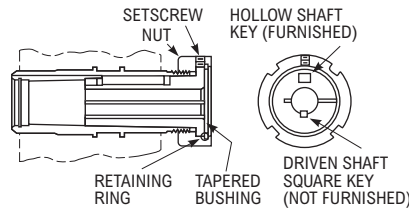

Bushing Size	Part Number <sup>⑤</sup>	Style No.	Driven Shaft Keyway/Min Key Length <sup>⑥</sup>	Wt (lb)
BU5415J-3.438	0769234	2	7/8 x 7/16 x 8	41.5
BU5415J-3.938	0769235	2	1 x 1/2 x 6	33.8
BU5415J-4.188	0769236	1	1 x 1/2 x 7-1/2	29.5
BU5415J-4.438	0769237	1	1 x 1/2 x 7-1/2	24.9
BU5415J-4.938	0769238	1	1-1/4 x 5/8 x 7-1/2	15.1

## Accessories

Torque Arm

TA5415J  
PN 0785272  
Wt. 56 lb

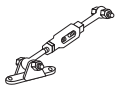

Backstop <sup>⑦</sup>

BS5415J14  
PN 0757220  
BS5415J25  
PN 0757221  
Wt. 22 lb



Thrust Plate Kit

TP5415J  
PN 0769233  
Wt. 8 lb



- ① Dimensions are for reference only and are subject to change without notice unless certified.
- ② MIN = Minimum required projection of driven shaft. MAX = Maximum projection of driven shaft which allows for use of thrust plate.
- ③ JR = Basic Drive + Bushing + Torque Arm  
JF = Basic Drive (Bushing Optional)  
JSC = Basic Drive + Seal Housing + Driveshaft
- ④ 0° incline down on drives with backstops in 9 or 12 o'clock mounting.
- ⑤ Consists of bushing, drive key, nut, retaining ring and setscrew.
- ⑥ Check strength of driven shaft and unfurnished key.
- ⑦ Not available in 5:1 ratio.

# Size 5415 Flange-Mounted (JF) Drive

## Dimensions (in) <sup>①</sup>

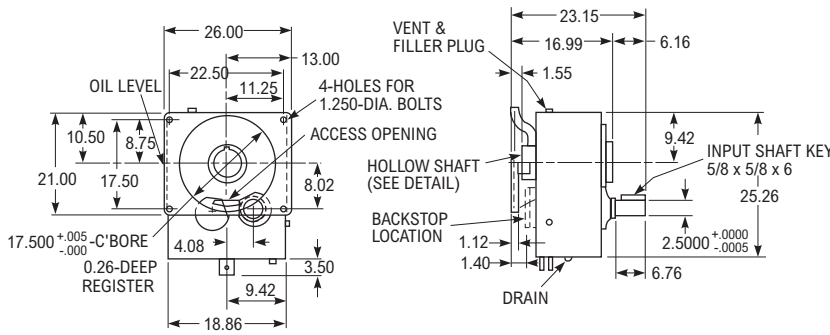

Drive Size <sup>②</sup>	Part Number	Exact Ratio	Max Output RPM	Wt (lb)
5415JF05A	0794397	5.077	350	890
5415JF14A	0794398	13.61	125	920
5415JF25A	0794399	26.11	70	920

## Motor Mounts

Standard Horizontal Drive Assembly – 3 o'clock (A3)

Refer to page 58 for minimum and maximum shaft centers for bottom and side mounting positions. The assemblies may also be rotated about the hollow shaft in 90° increments to position the input shaft in 3, 6, 9 and 12 o'clock positions, ±10° and mounted vertically.

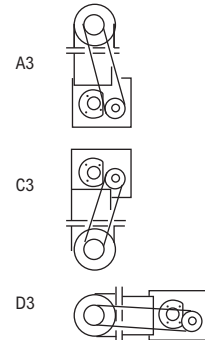
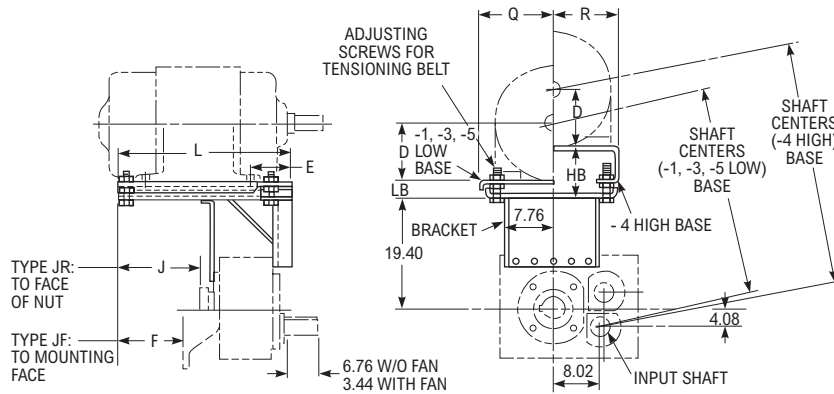

Frame	56	143-145T	182-184T	213-215T	254-256T	284-286T	324-326T	364-365T	404-405	444-449T
D	3.50	3.50	4.50	5.25	6.25	7.00	8.00	9.00	10.00	11.00
E	2.68	2.18	2.68	3.44	4.18	4.69	5.19	5.81	6.56	7.45
Shaft Centers <sup>③</sup>	Min-Max	Min-Max	Min-Max	Min-Max	Min-Max	Min-Max	Min-Max	Min-Max	Min-Max	Min-Max
-1 Low Base	29.5 - 33.2	29.5 - 33.2	30.4 - 34.2	31.2 - 34.9	—	—	—	—	—	—
-3 Low Base	—	—	—	—	32.7 - 36.5	33.5 - 37.3	34.4 - 38.3	35.4 - 39.2	36.4 - 40.2	—
-4 High Base	—	—	—	—	36.6 - 40.3	37.6 - 41.1	38.3 - 42.1	39.3 - 43.0	40.3 - 44.0	—
-5 Low Base	—	—	—	—	—	—	—	—	—	38.7 - 42.3

## Dimensions (in)

Motor Mount Size <sup>①</sup>	Part Number		Type T Frame		F	J	L	Q	R	HB	LB	Motor Mount Wt (lb)
	JR	JF	Min	Max						Min-Max	Min-Max	
MM5415J-1	0757623	0757624	56	215	1.70 <sup>④</sup>	1.82 <sup>⑤</sup>	15.00	8.16	—	—	1.02-4.84	88
MM5415J-3	0757625	0757627	254	405	9.59	9.47	26.26	11.88	—	—	2.14-5.96	196
MM5415J-4	0757626	0757628	254	405	9.59	9.47	26.26	—	11.62	6.00-9.80	—	218
MM5415J-5	0786638	0786639	444	449	17.33	17.21	34.00	16.00	—	—	3.37-7.00	325

① Dimensions are for reference only and are subject to change without notice unless certified. When determining belt length for minimum shaft centers, follow the belt manufacturer's installation allowance recommendations.

② JF = Drive (Includes Output Flange) (Bushing Optional).

③ Shaft centers can be increased up to 1-1/2 inches with shim blocks. See page 59 for shim blocks.

④ The drive mounting surface (or seal housing) extends beyond the motor mount by the value shown.

⑤ Protrudes beyond the motor mount.

# Size 5507 Shaft-Mounted (JR) Drive

## Dimensions (in) ①

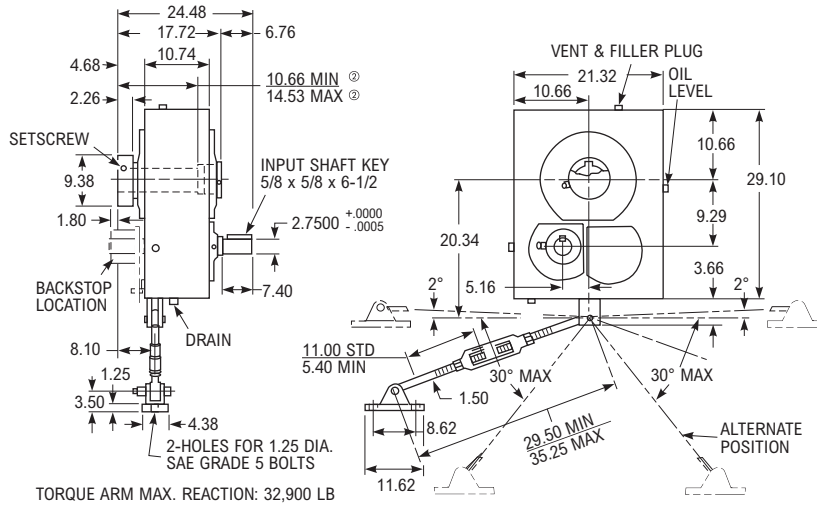

### Shaft Fan Kit

SFK5507J  
PN 0785893  
Wt. 5 lb.

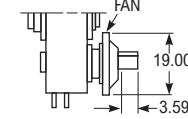

### Drive Mounting Positions

(Based on clock position of input shaft relative to hollow shaft.)

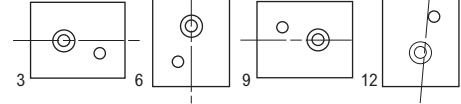

## Hollow Shaft Details

See Manual 377-140 for JF drive tapered driven shaft recommendations. See Manual 377-142 for JF drives using tapered bushings.

## Angular Limits for Horizontal Mounting

(All Clock Positions)

Refer to Factory for lubrication analysis of all inclined drives exceeding the maximum specified below.

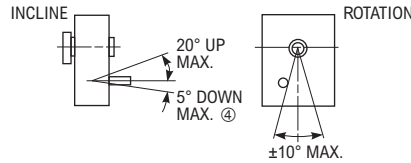

Drive Size ③	Part Number ⑤			Exact Ratio	Max Output RPM	Wt (lb)
	W/O Backstop	With Backstop	For Backstop ⑥			
5507JR05A	0795322	—	—	4.929 ⑦	350	—
5507JR14A	0795323	0795667	7706317	13.46	125	1065
5507JR25A	0795324	0795668	7706318	24.29	70	1065

## TA Taper Bushings

### Style No. 1 — Thin-wall bushing

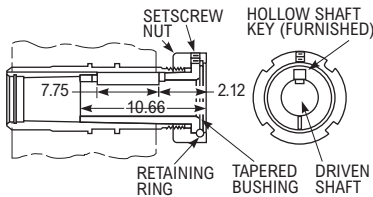

### Style No. 2 — Thick-wall bushing

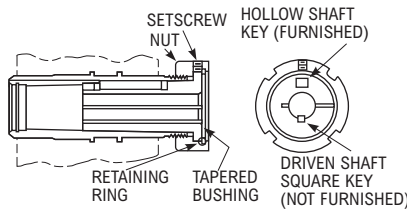

Bushing Size	Part Number ⑧	Style No.	Driven Shaft Keyway/Min Key Length ⑨	Wt (lb)
BU5507J-3.438	0786824	2	7/8 x 7/16 x 10	56.8
BU5507J-3.938	0786825	2	1 x 1/2 x 10	48.8
BU5507J-4.438	0786826	2	1 x 1/2 x 10	40.0
BU5507J-4.938	0785894	1	1-1/4 x 5/8 x 7-3/4	40.0
BU5507J-5.438	0785895	1	1-1/4 x 5/8 x 7-3/4	18.2

## Accessories

### Torque Arm

TA5507J  
PN 0785272  
Wt. 56 lb

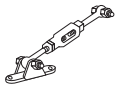

### Backstop ⑦

BS4507J14  
#0793687  
BS4507J25  
#0793688

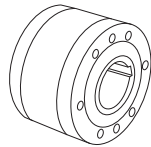

### Thrust Plate Kit

TP5507J  
PN 0769221  
Wt. 9 lb



- ① Dimensions are for reference only and are subject to change without notice unless certified.
- ② MIN = Minimum required projection of driven shaft. MAX = Maximum projection of driven shaft which allows for use of thrust plate.
- ③ JR = Drive (Includes Torque Arm).
- ④ 0° incline down on drives with backstops in 9 or 12 o'clock mounting.
- ⑤ These part numbers do not include bushing.
- ⑥ Drive modified to accept backstop, but does not include backstop.
- ⑦ Non-stock, refer to Factory.
- ⑧ Consists of bushing, drive key, nut, retaining ring and setscrew.
- ⑨ Check strength of driven shaft and unfurnished key.

# Size 5507 Flange-Mounted (JF) Drive

## Dimensions (in) ①

NOTE: Not available with backstop.

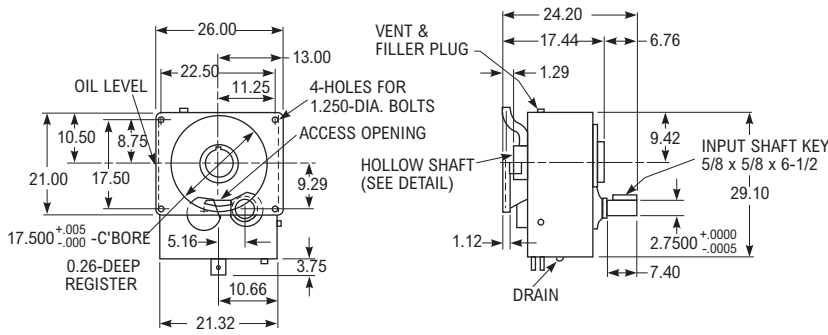

Drive Size ②	Part Number	Exact Ratio	Max Output RPM	Wt (lb)
5507JF05A	0794411	4.929 ③	350	—
5507JF14A	0794412	13.46	125	1200
5507JF25A	0794413	24.29	70	1200

## Motor Mounts

Standard Horizontal Drive Assembly – 3 o'clock (A3)

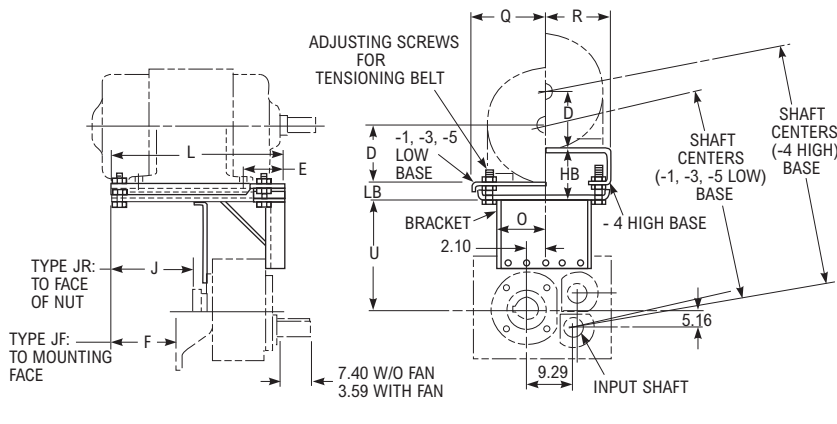

Refer to page 58 for minimum and maximum shaft centers for bottom and side mounting positions. The assemblies may also be rotated about the hollow shaft in 90° increments to position the input shaft in 3, 6, 9 and 12 o'clock positions, ±10° and mounted vertically.

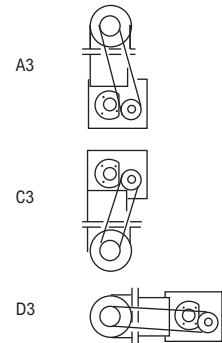

Frame	56	143-145T	182-184T	213-215T	254-256T	284-286T	324-326T	364-365T	404-405T	444-449T
D	3.50	3.50	4.50	5.25	6.25	7.00	8.00	9.00	10.00	11.00
E	2.68	2.18	2.68	3.44	4.18	4.69	5.19	5.81	6.56	7.44
Shaft Centers ④	Min-Max	Min-Max	Min-Max	Min-Max	Min-Max	Min-Max	Min-Max	Min-Max	Min-Max	Min-Max
-1 Low Base	31.5 - 35.5	31.5 - 35.5	32.5 - 36.5	33.2 - 37.2	—	—	—	—	—	—
-3 Low Base	—	—	—	—	34.9 - 38.7	35.7 - 39.4	36.6 - 40.4	37.6 - 41.4	38.6 - 42.4	—
-4 High Base	—	—	—	—	38.7 - 42.5	39.5 - 43.2	40.5 - 44.2	41.4 - 45.2	42.4 - 46.2	—
-5 Low Base	—	—	—	—	—	—	—	—	—	46.1 - 49.8

## Dimensions (in)

Motor Mount Size ⑤	Part Number		Type T Frame		F	J	L	O	Q	R	U	HB	LB	Motor Mount Wt (lb)
	JR	JF	Min	Max								Min-Max	Min-Max	
MM5507J-1	0757239	0757240	56	215	2.17 ⑥	2.51 ⑦	15.00	7.76	8.16	—	21.03	—	1.02-5.08	111
MM5507J-3	0757241	0757243	254	405	9.12	8.78	26.26	7.76	11.88	—	20.64	—	2.12-5.96	224
MM5507J-4	0757242	0757244	254	405	9.12	8.78	26.26	7.76	—	11.62	20.64	6.00-9.84	—	246
MM5507J-5	0769048	0769049	444	449	16.47	16.15	34.00	11.25	16.00	—	27.41	—	2.00-5.75	438

① Dimensions are for reference only and are subject to change without notice unless certified.

② JF = Drive (Includes Output Flange) (Bushing Optional).

③ Non-stock, refer to Factory.

④ Shaft centers can be increased up to 1-1/2 inches with shim blocks. See page 59 for shim blocks.

⑤ Dimensions are for reference only and are subject to change without notice unless certified. When determining belt length for minimum shaft centers, follow the belt manufacturer's installation allowance recommendations.

⑥ The drive mounting surface (or seal housing) extends beyond the motor mount by the value shown.

⑦ Protrudes beyond the motor mount.

# Size 5608 Shaft-Mounted (JR) Drive

## Dimensions (in) <sup>①</sup>

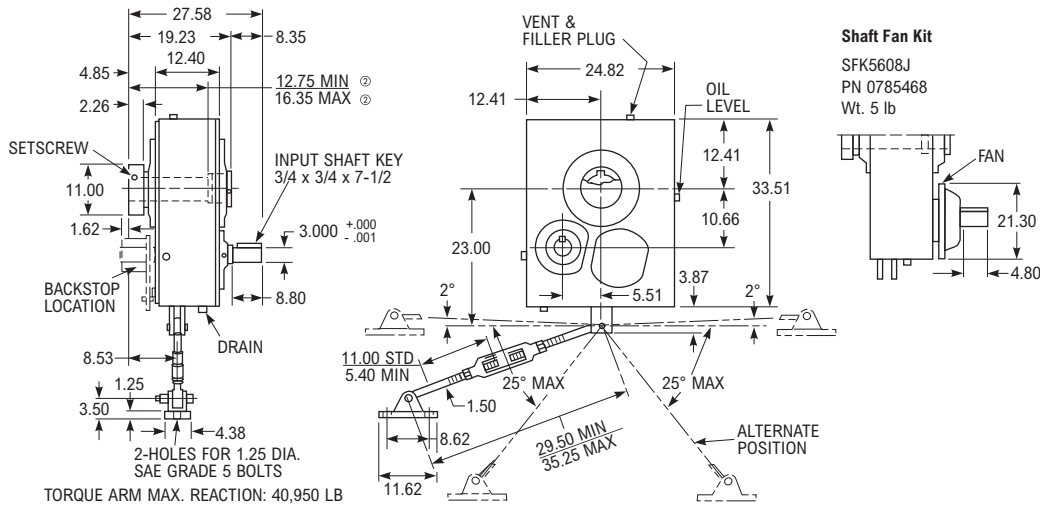

## Hollow Shaft Details

See Manual 377-140 for JF drive tapered driven shaft recommendations. See Manual 377-144 for JF drives using tapered bushings.

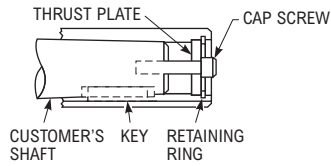

## Angular Limits for Horizontal Mounting

(All Clock Positions)

Refer to Factory for lubrication analysis of all inclined drives exceeding the maximum specified below.

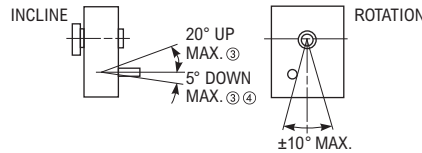

Drive Size <sup>⑤</sup>	Part Number <sup>⑥</sup>			Exact Ratio	Max Output RPM	Wt (lb)
	W/O Backstop	With Backstop	For Backstop <sup>⑦</sup>			
5608JR05A	0794701	—	—	5.00 <sup>⑧</sup>	350	—
5608JR14A	0794702	0794704	7706319	13.82	125	1800
5608JR25A	0794703	0794705	7706320	25.33	70	1800

## TA Taper Bushings

Style No. 1 — Thin-wall bushing

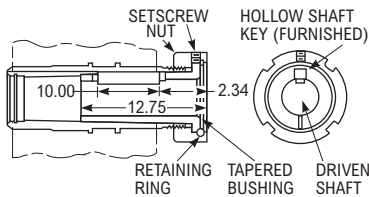

Bushing Size	Part Number <sup>⑨</sup>	Style No.	Driven Shaft Keyway/Min Key Length <sup>⑩</sup>	Wt (lb)
BU5608J-5.437	0769737	1	1-1/4 x 5/8 x 10	64.5
BU5608J-5.937	0769738	1	1-1/2 x 3/4 x 10	49.6
BU5608J-6.437	0765847	1	1-1/2 x 3/4 x 10	30.0
BU5608J-6.500	0769739	1	1-1/2 x 3/4 x 10	31.4

- ① Dimensions are for reference only and are subject to change without notice unless certified.
- ② MIN = Minimum required projection of driven shaft. MAX = Maximum projection of driven shaft which allows for use of thrust plate.
- ③ 5507 & 5608 — 5° incline on drives with backstops in all mounting positions.
- ④ 5407 & 5415 — 0° incline down on drives with backstops in 9 or 12 o'clock mounting positions.
- ⑤ JF = Drive (Includes Torque Arm).
- ⑥ These part numbers do not include bushings.
- ⑦ Drive modified to accept backstop, but does not include backstop.
- ⑧ Non-stock, refer to Factory.
- ⑨ Consists of bushing, drive key, nut, retaining ring and setscrew.
- ⑩ Check strength of driven shaft and unfurnished key.

# Size 5608 Flange-Mounted (JF) Drive

## Dimensions (in) <sup>①</sup>

**NOTE:** Not available with backstop.

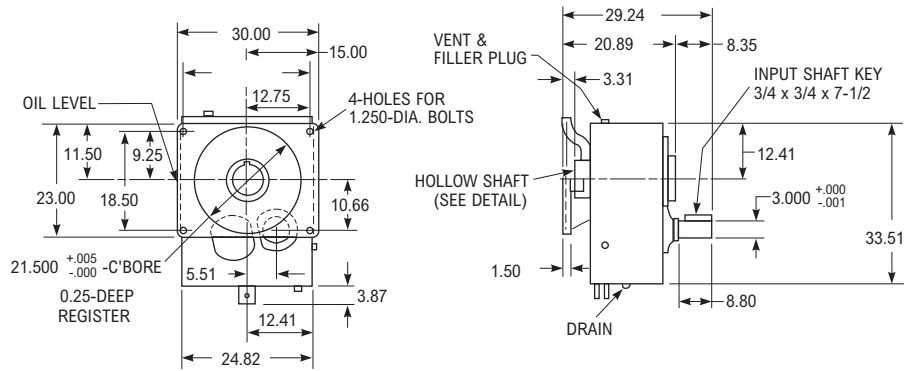

## Drive Mounting Positions

(Based on clock position of input shaft relative to hollow shaft.)

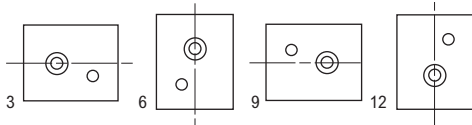

Drive Size <sup>②</sup>	Part Number	Exact Ratio	Max Output RPM	Wt (lb)
5608JF05A	0794414	5.00 <sup>③</sup>	350	—
5608JF14A	0794415	13.82	125	2100
5608JF25A	0794416	25.33	70	2100

## Accessories

Torque Arm

TA5608J  
PN 0785272  
Wt. 56 lb

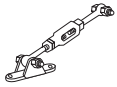

Backstop <sup>④</sup>

BS4608J14  
BS4608J25  
PN 0793687

Thrust Plate Kit

TP5608J  
PN 0769740  
Wt. 10 lb



① Dimensions are for reference only and are subject to change without notice unless certified.

② JF = Drive (Includes Output Flange) (Bushing Optional).

③ Non-stock, refer to Factory.

④ Not available with 5:1 ratios.

# Size 5608 Motor Mounts

## Dimensions (in) ①

Standard Horizontal Drive Assembly – 3 o'clock (A3)

Refer to page 58 for minimum and maximum shaft centers for bottom and side mounting positions. The assemblies may also be rotated about the hollow shaft in 90° increments to position the input shaft in 3, 6, 9 and 12 o'clock positions, ±10° and mounted vertically.

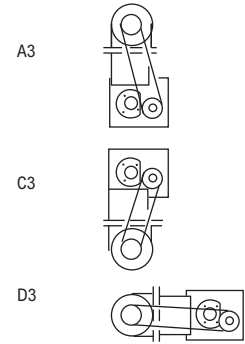
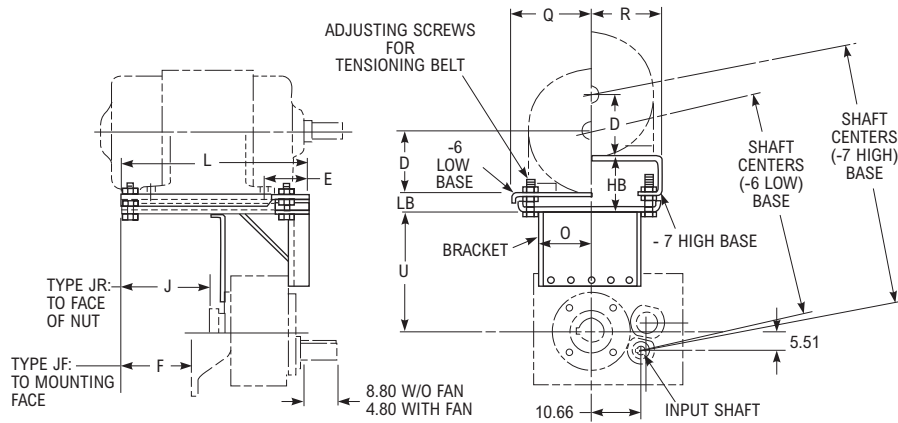

Frame	254-256T	284-286T	324-326T	364-365T	404-405T	444-449T
D	6.25	7.00	8.00	9.00	10.00	11.00
E	4.00	4.75	5.25	6.00	6.75	7.50
Shaft Centers ②	Min-Max	Min-Max	Min-Max	Min-Max	Min-Max	Min-Max
-6 Low Base	43.5 - 47.0	44.3 - 47.8	45.2 - 48.8	46.2 - 49.7	47.2 - 50.7	48.1 - 51.7
-7 High Base	47.2 - 50.8	47.9 - 51.6	48.9 - 52.5	49.9 - 53.5	50.8 - 54.5	—

## Dimensions (in)

Motor Mount Size ①	Part Number		Type T Frame		F	J	L	O	Q	R	U	HB	LB	Motor Mount Wt (lb)
	JR	JF	Min	Max								Min-Max	Min-Max	
MM5608J-6	0786722	0786723	254	449	12.71	14.38	34.00	13.50	16.00	—	27.06	—	3.38-7.00	450
MM5608J-7	0786720	0786721	254	405	12.71	14.38	34.00	13.50	—	15.12	27.06	7.13-10.87	—	460

① Dimensions are for reference only and are subject to change without notice unless certified. When determining belt length for minimum shaft centers, follow the belt manufacturer's installation allowance recommendations.

② Shaft centers can be increased up to 1-1/2 inches with shim blocks. See page 59 for shim blocks.

# Screw Conveyor Options

## Trough Ends — Sizes 6 through 24 inches

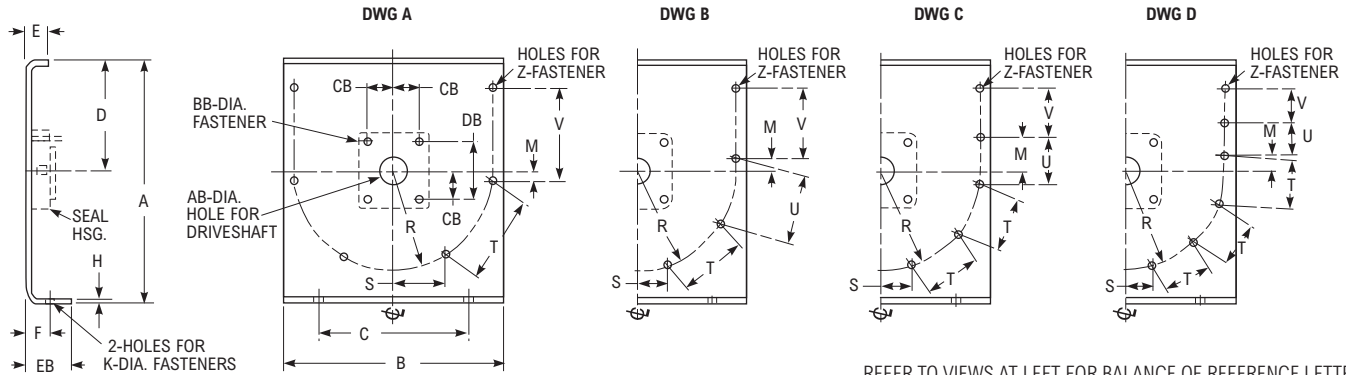

### Dimensions (in) ①

Screw Size	Drive-shaft Dia	Type JSC Size Range	Part Number	Above Dwg	AB	BB ②	CB	DB	EB	A	B	C	D	E	F	H	K	M	R	S	T	U	V	Wt (lb)	
6	1.500	5107-5203	0359263	A	2.25	0.500	2.000	4.000	1.8	10.1	10.0	8.125	4.5	1.50	1.000	0.188	0.375	0.638	4.438	2.032	4.062	—	4.125	7	
	1.500	5107-5203	0359264	B	2.25	0.500	2.000	4.000	2.6	14.0	13.7	9.375	6.1	1.62	1.500	0.250	0.500	0.821	6.250	2.562	3.750	4.125	4.125	18	
9	2.000	5107-5215	0359265	B	2.25	0.625	2.562	5.125	2.6	17.4	17.3	12.250	7.8	2.00	1.625	0.312	0.625	0.938	7.938	3.875	4.062	5.188	5.312	31	
	2.000	5107-5215	0359266	B	2.25	0.625	2.562	5.125	2.8	20.1	19.3	16.500	9.3	2.00	1.625	0.312	0.625	1.107	8.938	3.000	5.938	5.938	5.625	39	
12	2.438	5107-5315	0359272	B	2.56	0.625	2.812	5.625	2.8	22.6	21.3	14.875	10.6	2.50	2.000	0.312	0.625	1.609	10.000	3.750	6.625	9.625	6.375	51	
	3.000	5107-5315	0359273	B	3.12	0.750	3.000	6.000	2.9	25.5	24.3	16.000	12.1	2.50	2.000	0.375	0.625	3.478	11.000	2.938	5.875	5.875	5.938	73	
14	2.438	5107-5315	0359274	B	2.56	0.625	2.812	5.625	2.9	28.5	26.3	19.250	13.5	2.50	2.250	0.375	0.750	4.489	12.188	3.344	6.688	6.688	6.250	91	
	3.000	5107-5315	0359275	B	3.12	0.750	3.000	6.000	3.3	34.6	30.3	20.000	16.5	2.50	2.500	0.375	0.750	1.011	14.250	3.312	6.625	6.625	6.125	126	
16	3.000	5407	0359267	B	4.25	0.750	4.625	9.250	2.6																
	3.000	5107-5315	0359276	B	3.12	0.750	3.000	6.000	3.3																
18	3.000	5407	0359268	B	4.25	0.750	4.625	9.250	2.7																
	3.438	5407	0359268	B	4.25	0.750	4.625	9.250	2.7																
20	3.000	5107-5315	0359277	C	3.12	0.750	3.000	6.000	3.3																
	3.438	5215-5315	0359278	C	3.56	0.750	3.375	6.750	3.3																
24	3.000	5407	0359269	C	4.25	0.750	4.625	9.250	2.7																
	3.438	5407	0359269	C	4.25	0.750	4.625	9.250	2.7																

① Dimensions are for reference only and are subject to change without notice unless certified.

② Hex head screws are furnished with Falk™ driveshafts.

### 316 Stainless ③ Steel Driveshafts ④

Description	Part No.	Description	Part No.
<b>5107JSC Driveshafts</b>		<b>5215JSC Driveshafts</b>	
DSS5107-1.500	6720054	DSS5215J-2.000	6720071
DSS5107-2.000	6720055	DSS5215J-2.438	6720072
DSS5107-2.438	6720056	DSS5215J-3.000	6720073
DSS5107-3.000	6720057	DSS5215J-3.438	6720074
<b>5115JSC Driveshafts</b>		<b>5307JSC Driveshafts</b>	
DSS5115-1.500	6720058	DSS5307J-2.438	6720075
DSS5115-2.000	6720059	DSS5307J-3.000	6720076
DSS5115-2.438	6720060	DSS5307J-3.438	6720077
DSS5115-3.000	6720061	<b>5315JSC Driveshafts</b>	
<b>5203JSC Driveshafts</b>		DSS5315J-2.438	6720078
DSS5203-1.500	6720062	DSS5315J-3.000	6720079
DSS5203-2.000	6720063	DSS5315J-3.438	6720080
DSS5203-2.438	6720064	<b>5407JSC Driveshafts</b>	
DSS5203-3.000	6720065	DSS5407J-3.000	6720081
<b>5207JSC Driveshafts</b>		DSS5407J-3.438	6720081
DSS5207-1.500	6720066		
DSS5207-2.000	6720067		
DSS5207-2.438	6720068		
DSS5207-3.000	6720069		
DSS5207-3.438	6720070		

### Holes for Z-Fasteners

Screw Size	6	9	12	14	16	18	20	24
No.	6	8	8	8	8	10	10	12
Dia	0.375	0.375	0.500	0.500	0.625	0.625	0.625	0.625

③ Check torque and bending capacity of driven shaft and coupling bolt shear against load. Mechanical properties of stainless steel differ from those of carbon steel.

④ Furnished with thrust plate kit and stainless steel trough end-to-seal housing fasteners.

⑤ Refer to Manual 377-146 for details.

⑥ Kit consists of: Bushing, thrust plate, fastener, key, retaining ring and hardware.

# Nominal Sheave Ratios and V-Belts

**Sheave Ratios** — The table below lists the sheave ratios for nominal gear drive ratios and output speeds when driven by 1750 and 1170 rpm motors. If sheave ratios are required for other motor speeds, or if greater accuracy than ±3% is required for the output speed, calculate the sheave ratio with the following formula, using the exact gear ratios. Check the sheave pitch diameter against the allowable minimums in Table 2 and Table 3.

$$\text{Sheaved Ratio} = \frac{\text{Exact Motor Speed}}{\text{Exact Gear Drive Ratio} \times \text{Required Output Speed}}$$

**Drive Ratio Substitution** — Selections in and Table 16 list the most economical choice of drive size and ratio for a given output speed using 1750 or 1170 rpm motors. Standard drive ratios (not drive sizes) can be substituted in recommended drives. Consult Regal Rexnord™ factory.

**V-Belts** — Selections can be made from any belt manufacturer's catalog. If a Falk™ motor mount is used, refer to page 58 for dimensions and shaft centers. When determining belt length and minimum center distance, include belt installation allowance in calculations.

**Table 10 — Nominal Sheave Ratios**

Drive Output RPM	5:1 Ratio		Drive Output RPM	9:1 Ratio		Drive Output RPM	14:1 Ratio		Drive Output RPM	25:1 Ratio	
	Motor RPM			Motor RPM			Motor RPM			Motor RPM	
	1750	1170		1750	1170		1750	1170		1750	1170
372	1.06 ①	—	230	1.19 ①	—	160	1.28 ①	—	80	1.14 ①	—
362	1.03 ①	—	216	1.10 ①	—	155	1.23 ①	—	76	1.09 ①	—
356	1.02 ①	1.52 ①	204	1.05 ①	—	150	1.20 ①	—	73	1.04 ①	—
350	1.00	1.50 ①	194	1.00	1.51 ①	146	1.16 ①	—	70	1.00	—
338	1.04	1.44 ①	191	1.02	1.47 ①	139	1.11 ①	—	69	1.01	—
330	1.06	1.41 ①	180	1.08	1.39 ①	135	1.08 ①	—	67	1.04	—
323	1.08	1.38 ①	172	1.13	1.33 ①	130	1.04 ①	—	64	1.09	—
314	1.11	1.34 ①	162	1.20	1.25 ①	125	1.00	1.52 ①	62	1.13	—
307	1.14	1.31 ①	153	1.27	1.19 ①	120	1.04	1.45 ①	61	1.15	—
302	1.16	1.29 ①	148	1.31	1.15 ①	118	1.06	1.43 ①	59	1.19	—
290	1.21	1.24 ①	140	1.39	1.09 ①	113	1.11	1.37 ①	58	1.21	—
286	1.22	1.22 ①	135	1.44	1.04 ①	109	1.15	1.32 ①	57	1.23	—
280	1.25	1.20 ①	129	1.50	1.00	106	1.18	1.28 ①	56	1.25	—
276	1.27	1.18 ①	125	1.55	1.03	100	1.25	1.20 ①	55	1.27	—
272	1.29	1.16 ①	115	1.69	1.12	98	1.28	1.18 ①	54	1.30	—
268	1.31	1.15 ①	108	1.80	1.19	95	1.32	1.15 ①	53	1.32	—
259	1.35	1.11 ①	101	1.92	1.28	92	1.36	1.11 ①	52	1.35	—
251	1.39	1.07 ①	95	2.04	1.36	89	1.40	1.07 ①	50	1.40	—
244	1.43	1.04 ①	91	2.13	1.42	86	1.45	1.03 ①	48	1.46	—
241	1.45	1.03 ①	88	2.20	1.47	83	1.51	1.00	46	1.52	1.00
237	1.48	1.01 ①	85	2.28	1.52	79	1.58	1.05	45	1.56	1.03
234	1.50	1.00	84	2.31	1.54	76	1.64	1.09	44	1.59	1.05
228	1.54	1.03	80	2.43	1.61	74	1.69	1.12	43	1.63	1.08
223	1.57	1.05	77	2.52	1.68	70	1.79	1.19	42	1.67	1.10
220	1.59	1.06	74	2.62	1.74	69	1.81	1.20	41	1.71	1.13
216	1.62	1.08	71	2.73	1.82	67	1.87	1.24	40	1.75	1.16
210	1.67	1.11	69	2.81	1.87	64	1.95	1.30	39	1.79	1.19
206	1.70	1.14	67	2.90	1.93	60	2.08	1.38	38	1.84	1.22
204	1.72	1.15	64	3.03	2.02	58	2.16	1.43	37	1.89	1.25
201	1.74	1.16	62	3.13	2.08	56	2.23	1.48	36	1.94	1.29
196	1.79	1.19	61	3.18	2.11	54	2.31	1.54	35	2.00	1.32
192	1.82	1.22	60	3.23	2.15	52	2.40	1.60	34	2.06	1.36
185	1.89	1.26	59	3.29	2.19	50	2.50	1.66	33	2.12	1.40
180	1.94	1.30	58	3.34	2.22	48	2.60	1.73	32	2.19	1.45
174	2.01	1.34	57	3.40	2.26	46	2.72	1.80	31	2.26	1.49
172	2.03	1.36	56	3.46	2.30	45	2.78	1.84	30	2.33	1.54
168	2.08	1.39	55	3.53	2.34	44	2.84	1.89	29	2.41	1.60
164	2.13	1.43	54	3.59	2.39	43	2.91	1.93	28	2.50	1.65
160	2.19	1.46	53	3.66	2.43	42	2.98	1.98	27	2.59	1.71
157	2.23	1.49	52	3.73	2.48	41	3.05	2.02	26	2.69	1.78
151	2.32	1.55	51	3.80	2.53	40	3.13	2.08	25	2.80	1.85
146	2.40	1.60	50	3.88	2.58	39	3.21	2.13	24	2.92	1.93
141	2.48	1.66	49	3.96	2.63	38	3.29	2.18	23	3.04	2.01
133	2.63	1.76	48	4.04	2.69	37	3.38	2.24	22	3.18	2.10
126	2.78	1.86	47	4.13	2.74	36	3.47	2.31	21	3.33	2.20
122	2.87	1.92	46	4.22	2.80	35	3.57	2.37	20	3.50	2.32
118	2.97	1.98	45	4.31	2.87	34	3.68	2.44	19	3.68	2.44
114	3.07	2.05	44	4.41	2.93	33	3.79	2.52	18	3.89	2.57
108	3.24	2.17	43	4.51	3.00	32	3.91	2.59	17	4.12	2.72
103	3.40	2.27	42	4.62	3.07	31	4.03	2.68	16	4.38	2.89
101	3.47	2.32	41	4.73	3.15	30	4.17	2.77	15	4.67	3.09
97	3.61	2.41	40	4.85	3.23	29	4.31	2.86	14	5.00	3.31
94	3.72	2.49	39	4.97	3.31	28	4.46	2.96	13	5.38	3.56
92	3.80	2.54	38	5.11	3.39	27	4.63	3.07	12	5.83	3.86
90	3.89	2.60	37	5.24	3.49	26	4.81	3.19	11	6.36	4.21
			36	5.39	3.58	25	5.00	3.32	10	—	4.63
			35	5.54	3.69	24	5.21	3.46	9	—	5.14
			34	5.71	3.79	23	5.43	3.61	8	—	5.79
			33	5.88	3.91	22	5.68	3.77	7	—	6.62
			32	6.06	4.03	21	5.95	3.95	6	—	7.7
			31	—	4.16	20	6.25	4.15	5	—	9.3
			30	—	4.30	18	—	4.61	4	—	11.6
			29	—	4.45	16	—	5.19			
			28	—	4.61	14	—	5.93			
			27	—	4.78						
			26	—	4.96						
			25	—	5.16						
			24	—	5.38						
			23	—	5.61						

① Sheave Ratios are speed increasing combinations.

## V-Belt Guards

### Falk™ V-Belt Guards, Built for Maximum Safety and Serviceability

Falk V-belt guards offer more than just compliance with OSHA requirements. For one thing, they're available at a low initial cost. For another, their practical construction makes them extremely user-friendly. You can quickly install them without the need for mounting brackets. And since these covers are easy-to-remove and lightweight, they simplify field service of belt drives.

V-belt guards are available in sizes to fit most Quadrive™/V-belt combinations, or to be used with other Falk drives. They come in an expanded metal cover, with a safety-orange paint finish. Falk V-Belt Guards — easily installed, easily removed.

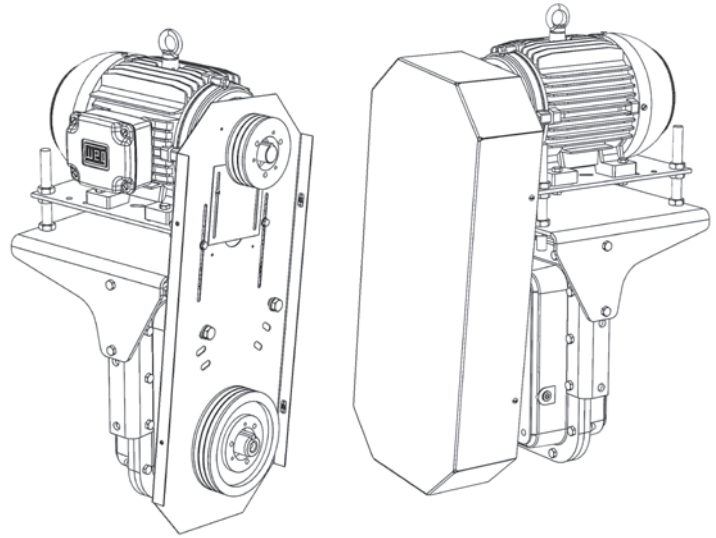

### Guard/Hardware Selection Procedure

- Using Table 11 and known belt drive information, determine which guards are suitable.

For overall guard dimensions, refer to Table 16.

**Table 11 — Standard V-Belt Guard Selection (in) ①**

Selection Parameter	Guard Size (Max Center Distance — Min Center Distance) ②											
	28	36N	36W	42N	42W, 42W F	48N	48W, 48W F	54	18E	19E, 19F	20E, 20F	21E, 21
Center Distance (Min)	14.00	19.50	16.00	24.50	22.00	30.50	28.00	34.00	34.00	34.00	32.00	42.50
Center Distance (Max)	18.50	26.50	23.00	31.50	29.00	38.50	35.00	41.00	42.00	42.00	42.00	56.00
Max Driver Shaft Dia	2.00	2.00	2.00	3.25	3.25	3.25	3.25	3.25	3.50	3.50	3.50	3.50
Max Driven Shaft Dia ③	1.50	1.50/2.50	1.50/2.50	1.50/2.50	1.50/2.50	1.50/2.50	1.50/2.50	2.50	3.00	3.00	3.00	3.00
Max Driver Sheave Dia	10.00	10.00	16.00	12.00	16.00	12.00	16.00	18.00	10.00	12.00	12.00	14.00
Max Driven Sheave Dia	10.00	10.00	16.00	12.00	16.00	12.00	16.00	18.00	15.00	20.00	28.00	32.00
Max Sheave Width	4.00	4.00	4.00	5.00	5.00	5.00	5.00	5.00	8.25	8.25	8.25	8.50
Overall Length	28.00	36.00	36.00	42.00	42.00	48.00	48.00	54.00	61.50	65.00	69.00	87.00

① Table allows for 1" of belt take-up adjustment.

② W = wide width belt guard.

③ Knock-out must be used for larger diameters.

- Determine availability of mounting hardware:

Is guard for use with Falk Quadrive?

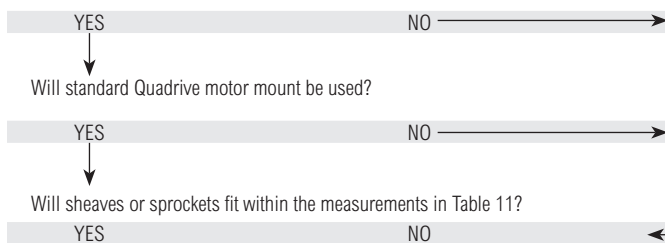

Supply guard complete with guard mounting brackets. See Table 12 for part numbers of drives w/o shaft fan. See Table 13 for part numbers of drives with shaft fan.

Option 1: Supply guard only (Table 14) with loose strapping by Regal Rexnord (Table 15). Regal Rexnord will provide 4 feet of 12 gauge strapping with sheet metal screws. Purchaser must cut, bend, drill and mount.

Option 2: Supply guard only (Table 14). Purchaser is responsible for all mounting.

### Mounting Positions

The A6 assembly is the most common mounting position. However, the motor mount and drive may be mounted in any of the positions shown below.

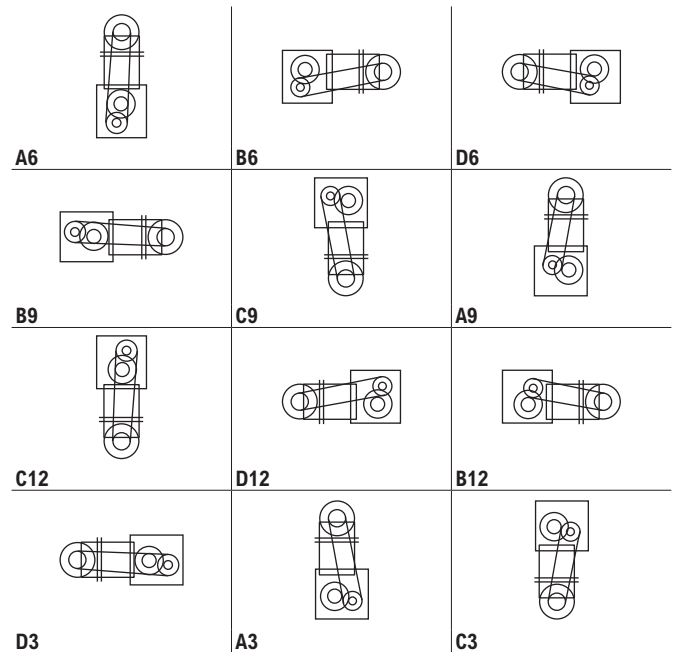

# V-Belt Guards

## Guard Part Numbers

**Table 12 — Part Numbers for Guards Including Quadrive™ Mounting Hardware — For Drives without Fan**

Drive Size	Motor Mount Position ②	Solid Cover Shaft Centers								Vented Cover Shaft Centers			
		28	36N	36W	42N	42W	48N	48W	54	18E	19E	20E	21E
5107	A6, B9, C12, D3	7708137	7708138	7708139	7708140	7708141	–	–	–	–	–	–	–
5115		7708137	7708138	7708139	7708140	7708141	–	–	–	–	–	–	–
5203		7708137	7708138	7708139	7708140	7708141	7708142	7708143	7708144	–	–	–	–
5207		–	7708138	7708139	7708140	7708141	7708142	7708143	7708144	–	–	–	–
5215		–	–	7708139	7708140	7708141	7708142	7708143	7708144	–	–	–	–
5307		–	–	–	–	7708141	7708142	7708143	7708144	–	–	–	–
5315		–	–	–	–	7708141	7708142	7708143	7708144	–	–	–	–
5407	A3, B6, C9, D12 A9, B12, C3, D6	–	–	–	–	–	–	–	–	0783768	0783772	0783776	–
	A6, B9, C12, D3	–	–	–	–	–	–	–	–	0783769	0783773	0783777	–
5415	A3, B6, C9, D12 A9, B12, C3, D6	–	–	–	–	–	–	–	–	0783780	0783784	0783788	–
	A6, B9, C12, D3	–	–	–	–	–	–	–	–	0783781	0783785	0783789	–
5507	A3, B6, C9, D12	–	–	–	–	–	–	–	–	0783792	0783796	0783800	–
	A9, B12, C3, D6	–	–	–	–	–	–	–	–	①	①	①	–
	A6, B9, C12, D3	–	–	–	–	–	–	–	–	0783793	0783797	0783801	–
5608	A3, B6, C9, D12 A9, B12, C3, D6	–	–	–	–	–	–	–	–	–	–	0786865	0786867
	A6, B9, C12, D3	–	–	–	–	–	–	–	–	–	–	0786866	0786868

① Quadrive mounting brackets are not available for these assembly positions.

② Refer to Mounting Positions diagram on previous page for motor mount positions.

**Table 13 — Part Numbers for Guards Including Quadrive Mounting Hardware — For Drives with Fan**

Drive Size	Motor Mount Position ②	Vented Cover for Fan Shaft Centers											
		28	36N	36W	42N	42W F	48N	48W F	54F	18F	19F	20F	21F
5215	ALL POSITIONS	–	–	–	–	7708145	–	7708146	7708147	–	0786872	–	–
5307		–	–	–	–	7708148	–	7708149	7708150	–	0786875	–	–
5315		–	–	–	–	7708151	–	7708152	7708153	–	0786878	–	–
5407	A3, B6, C9, D12 A9, B12, C3, D6 A6, B9, C12, D3	–	–	–	–	–	–	–	–	–	0786879	0786880	–
5415	A3, B6, C9, D12	–	–	–	–	–	–	–	–	–	0786881	0786882	–
	A9, B12, C3, D6 A6, B9, C12, D3	–	–	–	–	–	–	–	–	–	0786883	0786884	–
5507	A3, B6, C9, D12	–	–	–	–	–	–	–	–	–	0786885	0786886	–
	A9, B12, C3, D6	–	–	–	–	–	–	–	–	–	①	①	–
	A6, B9, C12, D3	–	–	–	–	–	–	–	–	–	0786887	0786888	–
5608	A3, B6, C9, D12 A9, B12, C3, D6	–	–	–	–	–	–	–	–	–	–	0786889	0786890

① Quadrive mounting brackets are not available for these assembly positions.

② Refer to Mounting Positions diagram on previous page for motor mount positions.

# V-Belt Guards

## Guard Part Numbers

**Table 14 — Part Numbers for Guard Only ①**

Size	With Solid Metal Cover
28	7708201
36N	7708202
36W	7708203
42N	7708204
42W	7708205
48N	7708206
48W	7708207
54	7708208
Size	With Expanded Metal Cover
18E	0783811
19E	0783813
20E	0783815
21E	0786860

**Table 15 — Options**

Option	Part Number
Loose strapping & hardware (Purchaser to cut, bend, drill & mount)	0783816

① Refer to Table 13 for guards used with fans. Guards for use with fans are not available without mounting brackets.

## Guard Dimensions

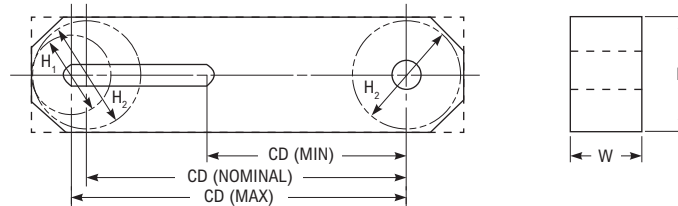

**Table 16 — Standard V-Belt Guard Dimensions (in)**

Dimension	Guard Size											
	28 ①	36N ①	36W ①	42N ①	42W, 42W F ①	48N ①	48W, 48W F ①	54, 54F ①	18E ②	19E, 19F ②	20E, 20F ②	21E, 21 ②
CD (Min)	13.50	19.00	15.50	24.00	21.50	30.00	27.50	33.50	34.00	34.00	32.00	42.50
CD (Nominal)	16.00	24.00	17.00	28.00	23.00	34.00	29.00	35.00	—	—	—	—
CD (Max)	20.00	27.00	23.50	32.00	29.50	38.00	35.50	41.50	45.50	45.50	45.50	59.50
Driver Sheave Clearance (H1)	③	③	③	③	③	③	③	③	13.00	15.00	15.00	17.00
Driven Sheave Clearance (H2)	11.00	11.00	18.00	13.00	18.00	13.00	18.00	18.00	18.00	23.00	31.00	35.00
Width (W)	5.00	5.00	5.00	6.00	6.00	6.00	6.00	6.00	9.25	9.25	9.25	10.00
Height (H)	12.00	12.00	19.00	14.00	19.00	14.00	19.00	19.00	18.50	23.50	31.50	36.50
Length (L)	28.00	36.00	36.00	42.00	42.00	48.00	48.00	54.00	61.50	65.00	69.00	87.00
Approximate Weight (lb) with Metal Cover	15	19	27	26	31	29	35	39	92	116	154	215

① Guards are 18 gauge steel.

② Guards are 14 gauge steel with expanded metal covers.

③ For center distances above CD (Nominal) use:  $H_1 = 2 \times (\text{LENGTH} - \text{CD}_{\text{ACTUAL}} - \frac{H_2}{2} - 1)$

# Reliability Package

## Sizes 5215-5315/Dimensions – Inch

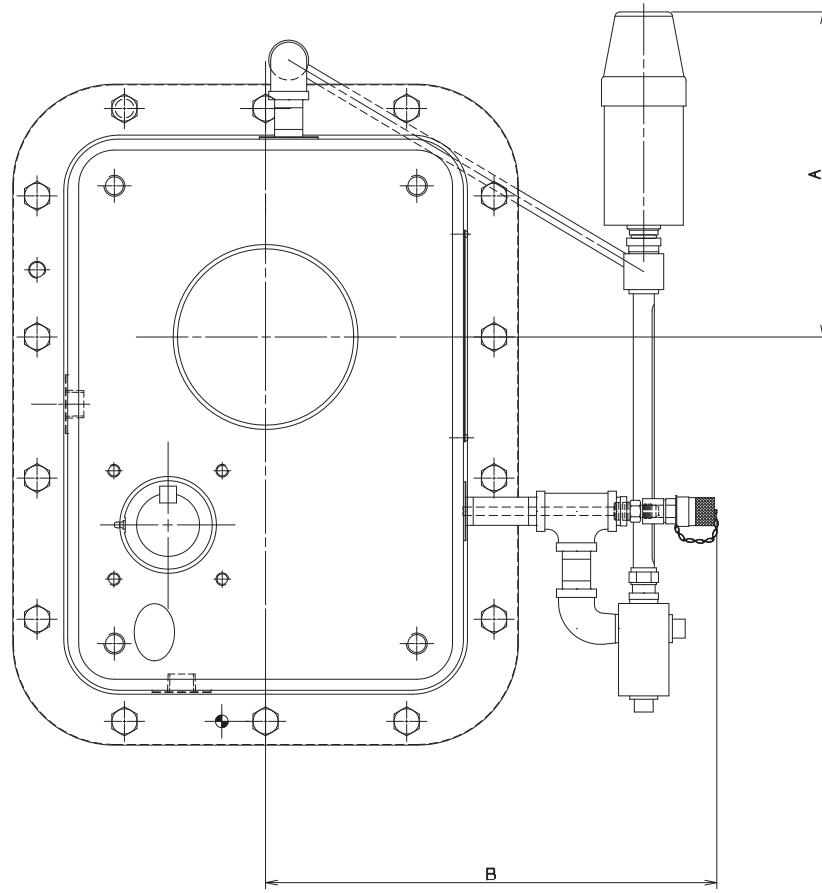

**Dimensions (Inch)**

DRIVE SIZE	A	B	Part Number
5215	9.68	13.46	7708104
5307	9.99	14.48	7708105
5315	9.99	14.48	7708105

# Reliability Package

## Sizes 5407-5608/Dimensions – Inch

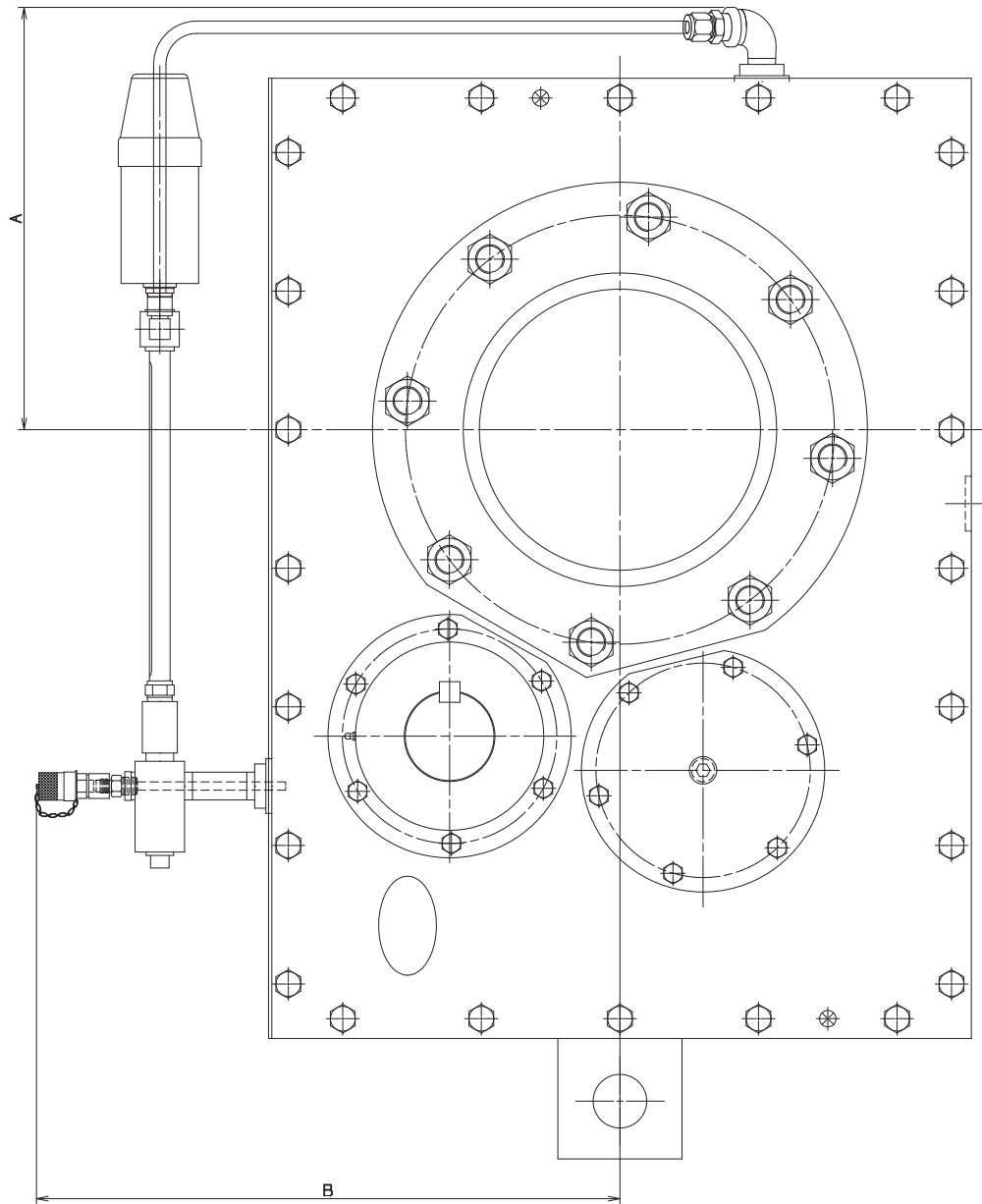

### Dimensions (Inch)

DRIVE SIZE	A	B	Part Number
5407	10.99	15.65	7708106
5415	11.81	16.44	7708107
5507	12.80	17.69	7708109
5608	14.56	19.45	7708108

# Electric Fan Options

Sizes 5307 & 5315

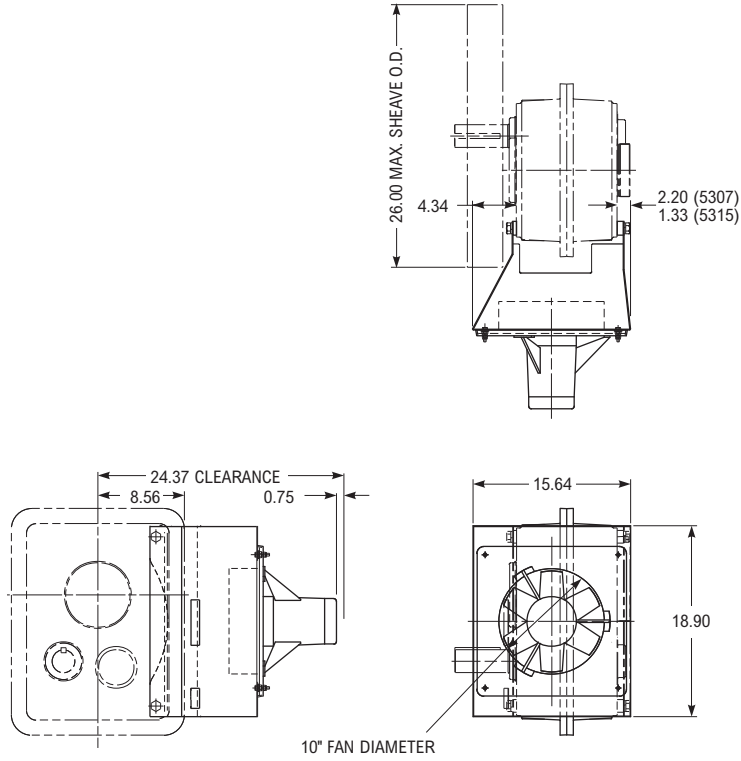

**Dimensions (in) ①**

Electric Fan Kits	Fan Blades Diameter	Electric Motors Specifications			Part No. ②
		Volts	Phase	Hertz	
EFK5307J	10	110	1	60	0787260
		220	1	60	0787261
		220	1	50	0787262
		220/380	3	50	0787263
EFK5315J	10	110	1	60	0787264
		220	1	60	0787265
		220	1	50	0787266
		220/380	3	50	0787267

① Dimensions are for reference only and are subject to change without notice unless certified.

② Includes fan, shroud and hardware (temperature switch not available).

# Electric Fan Options

## Sizes 5407 & 5608

Electric Fan, Temp. Switch & Bulb-Well Standard Location  
(Based on Drive Mounting Position)

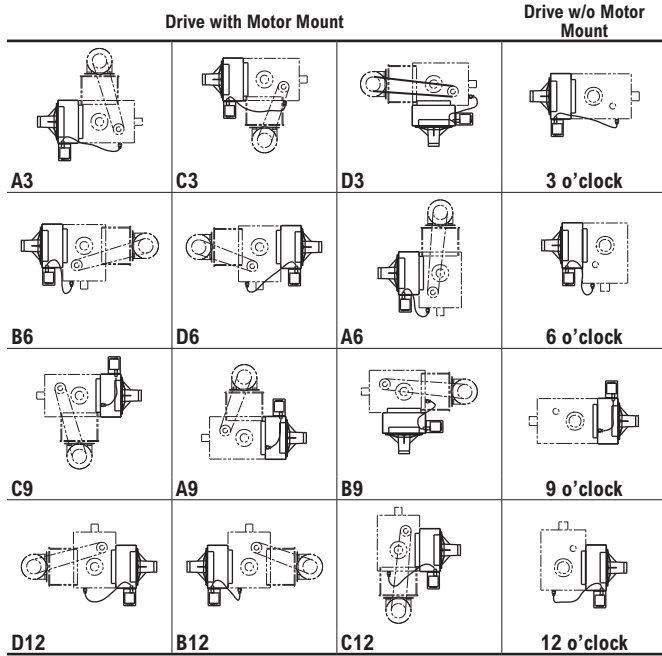

Electric Fan Kits	Fan Blades Diameter (in)	Electric Motors Specifications			Part No. ②
		Volts	Phase	Hertz	
EFK5407J	10	110	1	60	0787268
		220	1	60	0787269
		220	1	50	0787270
		220/380	3	50	0787271
EFK5415J	12	110	1	60	0787272
		220	1	60	0787273
		220/380	3	60	0787274
		265/460	3	60	0787275
EFK5507J	12	220/380	3	50	0787276
		110	1	60	0787277
		220	1	60	0787278
		220/380	3	60	0787279
EFK5608J	12	265/460	3	60	0787280
		220/380	3	50	0787281
		110	1	60	0787282
		220	1	60	0787283
		220/380	3	60	0787284
		265/460	3	60	0787285
		220/380	3	50	0787286

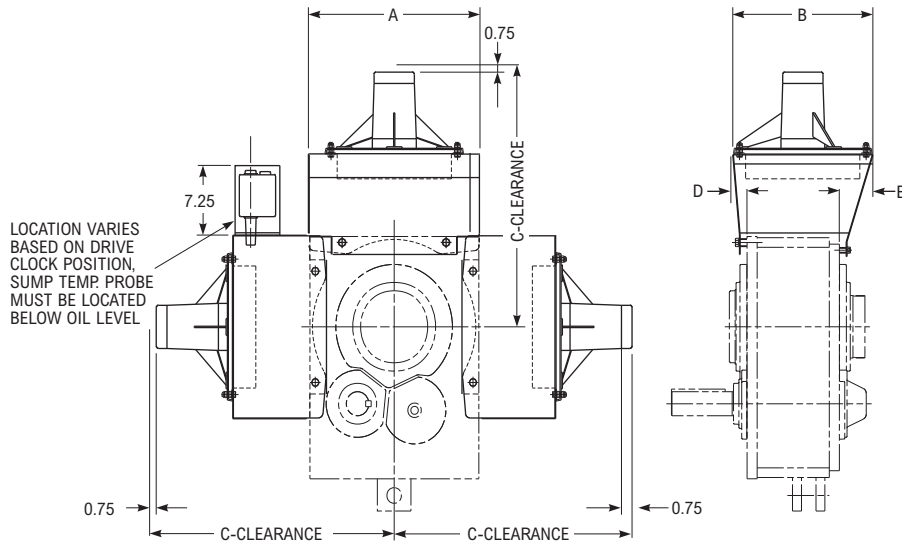

**NOTE:** The electric fan access can be mounted in any of the positions shown, bottom and side of the drive sump are the preferred locations.

### Dimensions (in) ①

Electric Fan Size	A	B	C	D	E
EF5407	19.20	15.70	30.00	1.60	5.80
EF5415	19.20	15.70	27.40	1.60	3.80
EF5507	22.40	15.70	28.60	1.40	3.60
EF5608	26.20	15.70	29.40	1.40	1.90

① Dimensions are for reference only and are subject to change without notice unless certified.

② Includes fan, shroud, temperature switch and hardware.

# Motor Mount Shaft Centers & Motor Frame Sizes

## Introduction

The following supplements the data published on pages 58-59. If shaft centers exceed the published maximum, refer complete data to Factory for engineering review.

## Mounting Positions

The A6 assembly is the most common mounting position. However, the motor mount and drive may be mounted in any of the positions shown at the right, except D3, B6, D6, B9, B12, and D12 limited to NEMA™\* 215 frame max for sizes 5107 through 5315. See Table 17 for center distance.

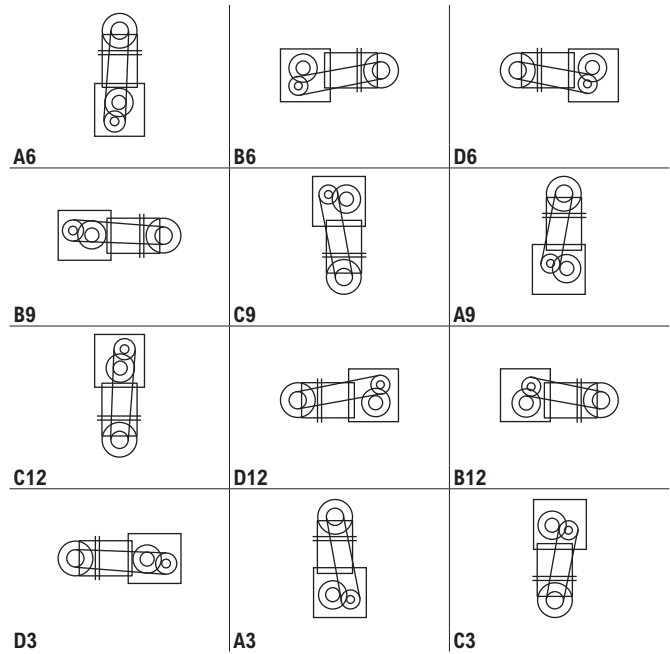

Table 17 — Motor-Driveshaft Centers (in)

Mounting Positions	Motor Frame Sizes	56T, 143T, 145T	182T 184T	213T 215T	254T 256T	284T 286T	324T 326T	364T 365T	404T 405T	444T, 445T, 447T, 449T
	Motor Mount Size	Shaft Centers Min-Max								
A3 B6 C9 D12	MM5407-1	28.0 - 31.9	28.9 - 32.9	29.6 - 33.6	—	—	—	—	—	—
	MM5407-3	—	—	—	31.4 - 35.1	32.1 - 35.8	33.0 - 36.8	34.0 - 37.7	35.0 - 38.7	—
	MM5407-4	—	—	—	35.1 - 38.9	35.8 - 39.6	36.8 - 40.6	37.8 - 41.5	38.8 - 42.5	—
	MM5407-5	—	—	—	—	—	—	—	—	37.2 - 40.7
	MM5415-1	29.5 - 33.2	30.4 - 34.2	31.2 - 34.9	—	—	—	—	—	—
	MM5415-3	—	—	—	32.7 - 36.5	33.5 - 37.3	34.4 - 38.3	35.4 - 39.2	36.4 - 40.2	—
	MM5415-4	—	—	—	36.6 - 40.3	37.6 - 41.1	38.3 - 42.1	39.3 - 43.0	40.3 - 44.0	—
	MM5415-5	—	—	—	—	—	—	—	—	38.7 - 42.3
	MM5507-1	31.5 - 35.5	32.5 - 36.5	33.2 - 37.2	—	—	—	—	—	—
	MM5507-3	—	—	—	34.9 - 38.7	35.7 - 39.4	36.6 - 40.4	37.6 - 41.4	38.6 - 42.4	—
	MM5507-4	—	—	—	38.7 - 42.5	39.5 - 43.2	40.5 - 44.2	41.4 - 45.2	42.4 - 46.2	—
	MM5507-5	—	—	—	—	—	—	—	—	46.1 - 49.8
MM5608-6	—	—	—	43.5 - 47.0	44.3 - 47.8	45.2 - 48.8	46.2 - 49.7	47.2 - 50.7	48.1 - 51.7	
MM5608-7	—	—	—	47.2 - 50.8	47.9 - 51.6	48.9 - 52.5	49.9 - 53.5	50.8 - 54.5	—	
C3 D6 A9 B12	MM5407-1	22.1 - 26.0	23.1 - 27.0	23.8 - 27.7	—	—	—	—	—	—
	MM5407-3	—	—	—	25.4 - 29.1	26.2 - 29.8	27.1 - 30.8	28.1 - 31.8	29.0 - 32.7	—
	MM5407-4	—	—	—	29.2 - 32.9	29.9 - 33.6	30.8 - 34.6	31.8 - 35.5	32.8 - 36.5	—
	MM5407-5	—	—	—	—	—	—	—	—	31.2 - 34.7
	MM5415-1	21.7 - 25.6	22.7 - 26.5	23.4 - 27.0	—	—	—	—	—	—
	MM5415-3	—	—	—	24.9 - 28.6	25.6 - 29.3	26.6 - 30.3	27.5 - 31.3	28.5 - 32.2	—
	MM5415-4	—	—	—	28.7 - 32.4	29.4 - 33.1	30.4 - 34.1	31.4 - 35.0	32.3 - 36.0	—
	MM5415-5	—	—	—	—	—	—	—	—	30.8 - 34.3
	MM5507-1	23.3 - 27.0	24.2 - 27.9	24.9 - 28.6	—	—	—	—	—	—
	MM5507-3	—	—	—	26.4 - 29.9	27.1 - 30.6	28.0 - 31.6	28.9 - 32.5	29.9 - 33.4	—
	MM5507-4	—	—	—	30.0 - 33.6	30.7 - 34.3	31.6 - 35.2	32.5 - 36.2	33.4 - 37.1	—
	MM5507-5	—	—	—	—	—	—	—	—	37.1 - 40.7
MM5608-6	—	—	—	33.0 - 36.4	33.7 - 37.1	34.6 - 38.1	35.6 - 39.0	36.5 - 40.0	37.5 - 41.0	
MM5608-7	—	—	—	36.5 - 40.1	37.2 - 40.9	38.2 - 41.8	39.2 - 42.8	40.1 - 43.8	—	
D3 A6 B9 C12	MM5407-1	31.8 - 35.9	32.8 - 36.9	33.6 - 37.7	—	—	—	—	—	—
	MM5407-3	—	—	—	35.3 - 39.2	36.1 - 39.9	37.1 - 40.9	38.1 - 41.9	39.1 - 42.9	—
	MM5407-4	—	—	—	39.2 - 43.0	40.0 - 43.8	41.0 - 44.8	41.9 - 45.8	42.9 - 46.7	—
	MM5407-5	—	—	—	—	—	—	—	—	41.4 - 45.0
	MM5415-1	32.6 - 36.6	33.6 - 37.6	34.3 - 38.3	—	—	—	—	—	—
	MM5415-3	—	—	—	35.9 - 39.8	36.7 - 40.5	37.6 - 41.5	38.6 - 42.5	39.6 - 43.5	—
	MM5415-4	—	—	—	39.9 - 43.7	40.6 - 44.4	41.6 - 45.4	42.6 - 46.4	43.6 - 47.4	—
	MM5415-5	—	—	—	—	—	—	—	—	42.0 - 45.6
	MM5507-1	35.6 - 39.6	36.5 - 40.5	37.3 - 41.3	—	—	—	—	—	—
	MM5507-3	—	—	—	39.0 - 42.8	39.7 - 43.5	40.7 - 44.5	41.7 - 45.5	42.7 - 46.5	—
	MM5507-4	—	—	—	42.8 - 46.6	43.5 - 47.3	44.5 - 48.3	45.5 - 49.3	46.5 - 50.3	—
	MM5507-5	—	—	—	—	—	—	—	—	50.3 - 53.9
MM5608-6	—	—	—	47.7 - 51.3	48.4 - 52.0	49.4 - 53.0	50.4 - 54.0	51.4 - 55.0	52.4 - 56.0	
MM5608-7	—	—	—	51.4 - 55.1	52.1 - 55.9	53.1 - 56.9	54.1 - 57.9	55.1 - 58.9	—	

\*NEMA is believed to be the trademark and/or trade name of the National Electrical Manufacturers Association and is not owned or controlled by Regal Rexnord Corporation.

## Accessories/Options

### Shim Blocks (in)

Shim Block		Part Number		
No.	Thickness	56-215T	254-365T	404-449T
X 1/2	0.5	0711640	0711645	0759948
X 1	1.0	0711643	0745025	0759949
X 1-1/2	1.5	0709360	0709361	0709363

**Shim Blocks – All Sizes** — Shim blocks are available (at no extra charge when ordered with the motor mount) to increase the shaft centers up to 1-1/2" as shown. Specify thickness required when ordering motor mount. These may be used with either the short center low bases or the long center high bases to assist in matching the shaft centers to the available V-belt centers. Please specify size shim block required; X 1/2, X 1 or X 1-1/2.

### TA Removal Tool

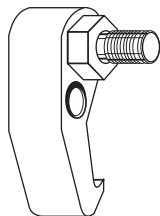

RT5107-5315J    PN 0769406    Wt. 8 lb  
(Tool with 5 adapters and case)

RT5407-5608J    PN 0769407    Wt. 10 lb  
(Tool with 2 adapters and case)

### AGMA Size Comparison

Max Bore (in)	AGMA	Falk™		Browning™	Dodge™		Sumitomo/Fenner™	Link-Belt™	Dorris™
		4000J	5000J		TXT	TAIL			
1-7/16	107	4107J	5107J	107SMT	TXT1	TA0107	107 C	107FX	107TR
1-15/16	115	4115J	5115J	115SMT	TXT2	TA2115	115 D	115FX	115TR
2-3/16	203	4203J	5203J	203SMT	TXT3	TA3203	203 E	203FX	203TR
2-7/16	207	4207J	5207J	207SMT	TXT4	TA4207	207 F	207FX	207TR
2-15/16	215	4215J	5215J	215SMT	TXT5	TA5215	215 G	215FX	215TR
3-7/16	307	4307J	5307J	307SMT	TXT6	TA6307	307 H	307FX	307TR
3-15/16	315	4315J	5315J	315SMT	TXT7	TA7315	315 J	315FX	315TR
4-7/16	407	4407J	5407J	407SMT	TXT8	TA8407	407 S	407FX	407TR
4-15/16	415	4415J	5415J	415SMT	TXT9	TA9415	415 K	415FX	415TR
5-7/16	507	4507J	5507J	507SMT	TXT10	TA10507	507 L	507D	507TR
6-1/2	608	4608J	5608J	608SMT	TXT12	TA12608	608 M	608D	608TR

For a competitive interchange, contact your Regal Rexnord™ District Office or local authorized Regal Rexnord distributor.

*Dodge is believed to be a trademark of Dodge Industrial, Inc. or one of its affiliated companies and is not owned or controlled by Regal Rexnord Corporation.*

*Sumitomo/Fenner is believed to be a trademark of Sumitomo Corporation or one of its affiliated companies and is not owned or controlled by Regal Rexnord Corporation.*

*Dorris is believed to be a trademark of Dorris Gear Drives or one of its affiliated companies and is not owned or controlled by Regal Rexnord Corporation.*

# Suggested Drive Arrangement When Falk™ Motor Mount Is Not Used

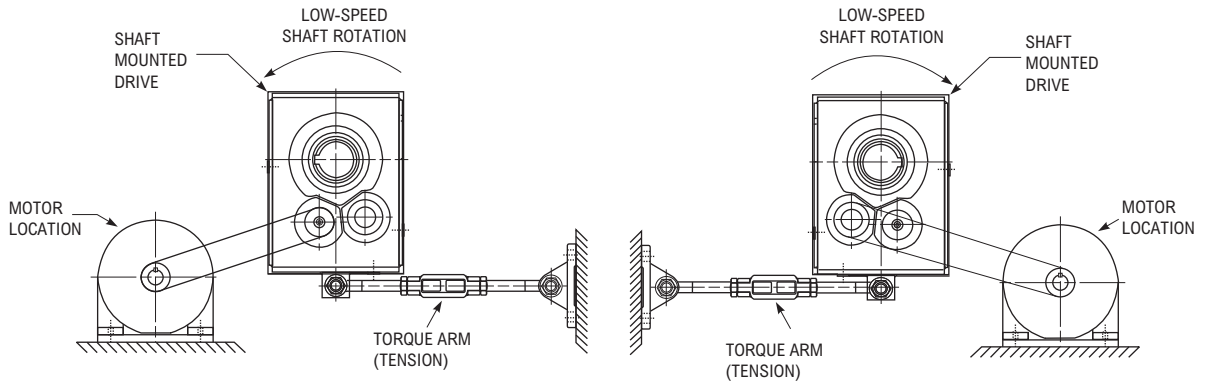

**PREFERRED**

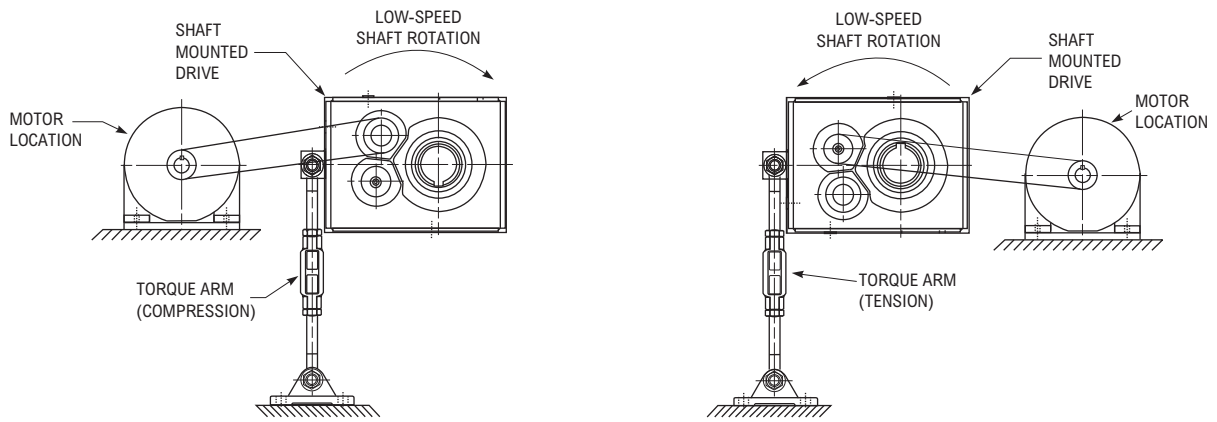

**ALTERNATE**









**FALK™**

**Regal Rexnord**

Contact us: [rexnord.com/contact](https://www.rexnord.com/contact)

[regalrexnord.com](https://www.regalrexnord.com)

The proper selection and application of products and components, including assuring that the product is safe for its intended use, are the responsibility of the customer. To view our Application Considerations, please visit <https://www.regalrexnord.com/Application-Considerations>.

To view our Standard Terms and Conditions of Sale, please visit <https://www.regalrexnord.com/Terms-and-Conditions-of-Sale> (which may redirect to other website locations based on product family).

"Regal Rexnord" is not indicative of legal entity. Refer to product purchase documentation for the applicable legal entity. Regal Rexnord, Browning, Falk, Link-Belt and Quadrive are trademarks of Regal Rexnord Corporation or one of its affiliated companies.

© 2013, 2025 Regal Rexnord Corporation, All Rights Reserved. MCC-371-110-FK-EN-US 01/25



**RegalRexnord™**